



**STANDARD
SPECIFICATIONS
SEWER CONSTRUCTION**

2020

Copyright © The City of Calgary 2020

No part of this work may be reproduced by any means
without written permission from The City of Calgary.



This document can be downloaded at www.calgary.ca/UD.

TERMS OF USE

The “2020 Standard Specifications Sewer Construction” is made available for use in the City of Calgary effective as of the date below.

June 11, 2020

Date



June 8, 2020

May Cayanan, P.Eng, M.Eng
Team Lead, Standards and Agreements, Infrastructure Delivery

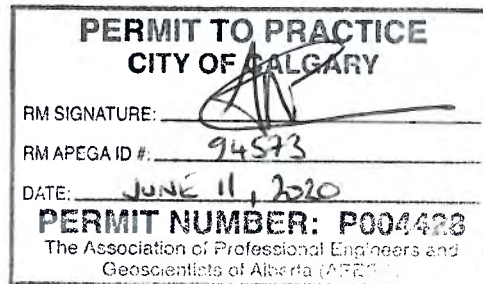

Andy Hughes, P.Eng, M.Eng
Manager, Infrastructure Delivery, Water Resources

The “2020 Standard Specifications Sewer Construction” is presented as accurate and complete as of the date indicated above. Use of these Specifications shall not absolve any user from the obligation to exercise their professional judgment and follow good practice. Should any user have question as to the intent or accuracy of any specification or drawing herein, or concern that conflict may exist between the manufacturers’ or suppliers’ recommended installation procedures and these Specifications, the user is advised to seek clarification from the Manager, Infrastructure Delivery.

IMPORTANT NOTICE

DANGER

Hazardous conditions could exist within The City of Calgary's wastewater and storm sewer collection systems. Please take the necessary precautions prior to making any connections to or entering into either system.

Prior to proceeding with any work on either system, please check the manholes within the immediate area. If you come across a red flag (see illustration below), work within or connection to the system cannot proceed until you have received approval from Water Services (3-1-1). Information will be provided to you on the hazards identified at specific manhole locations. If you require a complete list of locations throughout the city where access restrictions exist, contact Water Services at 3-1-1.

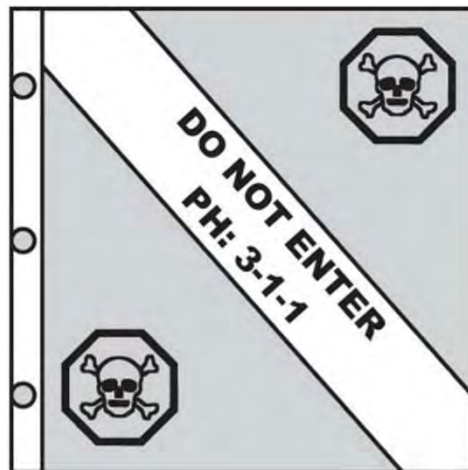

2020 Sewer Construction Specification Revisions

The following is a list of technical revisions to the *Standard Specifications Sewer Construction*. Revisions for 2020 are noted in ***bold italics***.

Section	Changes
401.02.00	Revised contact information
401.04.02	Revised ASTM codes to reflect current standards
401.05.00	Revised information for Report Submissions
402.01.01	Reinforced Concrete Pipe - added suppliers
402.01.01	PVC Pipe – added product
402.01.01	Corrugated Steel Pipe - revised certification requirements for CSP/SPCSP
402.01.02	Concrete Box Conduit – revised applicable Standards
402.01.02	Couplings for PVC Pipe – added product
402.01.02	Mortar – removed table
402.01.02	Crack and Joint Seal Repair Chemicals and Compounds – Revised Section
402.01.03	Casing Spacers - added product
402.01.03	End Seals for Encasement Pipe - added products
402.01.04	Service Lead Pipes - revised HDPE use
402.01.04	Updated Connector Sealants and Service Connectors
402.01.04	Added note regarding the use of Mission Rubber saddles
402.01.05	Manhole Covers - revised manhole covers based on line of service, added universal lock-out device
402.01.05	Manhole Steps - revised approved products
402.01.05	Manholes – revised table, added products for large diameter
402.01.05	Manhole Connections – updated wording, added product
402.01.05	Manhole Barrel Jointing Material - added products
402.01.06	Catch Basin Grates and Frames – updated suppliers
402.01.06	Spigot-Up Catch Basin Barrels - revised to spigot-up barrels
402.01.06	ICDs - revised content for stainless steel ICD and suppliers
402.01.08	Added product

Section	Changes
402.03.01	Added fall arrest content
402.03.04	Revised certification requirements
402.03.05	Added Manhole Connection requirement for profile pipe
402.03.07	Added section for FRP pipe
402.06.01	Revised content. Raised 28-day strength, updated reference to Drawing sheet 1B
402.06.02	Added new approved product and updated ASTM standard
402.06.04	Revised content, added accelerated set mortaring
402.07.01	Raised minimum concrete compressive strength
402.09.05	Added requirements for high early strength mix design
403.02.01	Revised content on excavation in close proximity to other line of service. Updated form of contact for Inspection Services
403.03.02	Revised requirements in different areas
403.04.02	Revised table
403.05.01	Revised/Added language on joint pull requirements
403.05.02	Revised note for additional water sources
403.05.03	Revised note for additional water sources
403.05.04	Revised wording from clay to groundwater for plugs
403.09.01	Revised section
403.09.03	Added note on item 4, updated manhole sizing
403.09.04	Updated concrete requirements to 35 MPa
403.09.06	Settings and Adjustments - added alternate for seal on manhole slab top, collars and frame. Added Products.
403.10.01	Revised Section
403.10.02	Revised content
403.10.04	Revised to require 2.0m asphalt apron
403.10.05	Revised to require 2.0m concrete apron
403.13.01	Revised max pipe size for image based inspection to 1500mm
403.13.04	Clarified Deflection testing requirements.
403.13.05	Revised section on video review / added penalty table
403.13.05	Revised video requirements

Section	Changes
403.13.05	Revised submission to City requirements
403.15.00	Updated titles and terminology throughout all sub-sections
403.15.00	Added reference to LID Module 2
403.15.02	Revised minimum size for subdrain to 150mm
All Sheets	Updated minimum concrete strength to 35 MPa
Sheet 1, 1A	Revised to new “lines of service” Manhole Design
Sheet 1B,1C	New maximum access and locking manhole sheets
Sheet 4	Sheet updated
Sheet 4A	Revised lip depth on sheet
Sheet 6	Revised Sheet, Updated min. concrete strength
Sheet 9	Revised step detail
Sheet 12	Added note barring connections to T-Riser section
Sheet 18B	Added 2400 and 3000 manhole information
Sheet 18C	Added 2400 and 3000 manhole information
Sheet 19	Added dimension from inlet to invert of channel
Sheet 33	Warning tape added to sheet.
Sheet 35	Updated details, added references to current manhole connection requirements
Sheet 38	Updated to current sealant and joint material spec
Sheet 38A	Updated to current sealant and joint material spec
Sheet 38B	Updated to current sealant spec
Sheet 39	Updated for ½ pipe or ¾ pipe channels, added sweep channels
Sheet 47	Updated 2.0m asphalt/concrete requirement around catch basin
Sheet 50	Updated 2.0m asphalt/concrete requirement around catch basin
Sheet 43A-2	Updated to include frost strap kit
Sheet 62	Added sheet to detail outlet control structure
Sheet 66	Added sheet to detail sub-drains / Clean outs
Sheet 67	Added sheet – detail of concrete collar

STANDARD SPECIFICATIONS

SEWER CONSTRUCTION

Table of Contents

401.00.00 SCOPE	13
401.01.00 INSPECTION	13
401.02.00 WATER RESOURCES INSPECTION CONTACT	14
401.03.00 UTILITY AND PIPELINE LOCATION NUMBERS	14
401.04.00 REFERENCES	15
401.05.00 REPORT SUBMISSIONS	20
402.00.00 MATERIALS	21
402.01.00 APPROVED PRODUCTS LIST	21
402.01.01 Pipe	21
402.01.02 Sewer Pipe Joints and Fittings	25
402.01.03 Casing Spacers	28
402.01.04 Services	29
402.01.05 Manholes	32
402.01.06 Catch Basins	38
402.01.07 Warning Tape	41
402.01.08 Oil-Grit Separators and Oil-Water Interceptor	42
402.02.00 GENERAL	42
402.03.00 SEWER PIPE	42
402.03.01 Concrete Pipe	42
402.03.02 Reinforced Concrete Box Conduit (Duct)	43
402.03.03 PVC Pipe	44
402.03.04 Corrugated Steel Pipe	44
402.03.05 Profile Pipe	46
402.03.06 HDPE Pipe	46
402.03.07 FRP Pipe	47
402.04.00 SEWER PIPE JOINTS, FITTINGS AND CASING SPACERS	48
402.04.01 Gaskets	48
402.04.02 Mortar	48
402.04.03 Sewer Pipe Plug	48
402.04.04 Concrete Box Conduit Joints	49
402.04.05 Fabricated and Injection Molded Fittings and Couplings for PVC Sewer Pipe	49

402.04.06	Casing Spacers for Carrier and Encasement Pipe	49
402.05.00	SERVICES	49
402.05.01	Service Leads	49
402.05.02	Service Lead Jointing Material	50
402.05.03	Service Lead Bends, Adaptors, Fittings and Connectors	50
402.05.04	Connector Sealants	50
402.06.00	MANHOLES	50
402.06.01	Manholes - General	50
402.06.02	Manhole Barrel Jointing Material	51
402.06.03	Manhole Steps	52
402.06.04	Mortar	52
402.07.00	CATCH BASINS	52
402.07.01	Catch Basins - General	52
402.07.02	Sump Catch Basins	53
402.08.00	STANDARD DRAINAGE SWALE	53
402.09.00	CAST-IN-PLACE CONCRETE	53
402.09.01	Concrete Formwork	53
402.09.02	Concrete Reinforcement	54
402.09.03	Structural Concrete	55
402.09.04	Testing Requirements	56
402.09.05	Mix Design	58
402.10.00	EMBEDMENT MATERIAL	58
402.10.01	Bedding Material	58
402.10.02	Concrete Encasement	59
402.10.03	Warning Tape	60
402.11.00	FOUNDATION STABILIZATION MATERIAL	60
402.12.00	CASTINGS	60
402.12.01	General	60
402.12.02	Manhole	61
402.12.03	Catch Basin	61
403.00.00	INSTALLATION	62
403.01.00	METHOD OF OBTAINING GRADE	62
403.01.01	General	62
403.01.02	Line	62
403.01.03	Grade	62
403.02.00	EXCAVATION	63
403.02.01	General	63
403.02.02	Rock Excavation	64
403.02.03	Explosives and Blasting	64
403.02.04	Tunneling	65
403.02.05	Utility Crossings - General	65

403.02.06	Supported Trenches - General.....	65
403.03.00	INSPECTION	66
403.03.01	Inspection - General	66
403.03.02	Pipe Inspection - General	66
403.03.03	Verification of Proposed Construction Method Consistent with Design Intent.....	68
403.04.00	FOUNDATION AND EMBEDMENT INSTALLATION.....	69
403.04.01	Foundation Installation.....	69
403.04.02	Embedment Installation	69
403.04.03	Bedding	71
403.04.04	Haunch and Initial Backfill.....	71
403.04.05	Change in Native Soil Conditions.....	72
403.04.06	Final Backfill	72
403.04.07	Manhole Bedding.....	72
403.04.08	Concrete Drainage Swale	72
403.05.00	PIPE INSTALLATION.....	72
403.05.01	General.....	72
403.05.02	Sanitary Sewer Pipe	73
403.05.03	Storm Sewer Pipe.....	73
403.05.04	Corrugated Steel Pipe - Round	74
403.05.05	PVC Solid Wall and Profile Pipe	75
403.05.06	HDPE Pipe Bursting Procedures for Replacing Sanitary Services	75
403.05.07	Jointing of HDPE Pipe for Sanitary Sewer Force mains.....	77
403.05.08	HDPE Pipe Restraints for Sanitary Sewer Force mains	77
403.05.09	Carrier and Encasement Pipe	77
403.05.10	Frost Protection	78
403.05.11	Precast Concrete Box Conduit (Duct)	79
403.06.00	SERVICE CONNECTIONS	79
403.07.00	BACKFILLING	81
403.07.01	General.....	81
403.07.02	Sewer Pipe	81
403.07.03	Sewer Duct.....	81
403.07.04	Manholes and other Related Structures.....	81
403.07.05	Groundwater Plugs and Weeping Holes at Storm Manholes.....	82
403.08.00	BACKFILL COMPACTION REQUIREMENTS	82
403.08.01	Moisture Requirements.....	82
403.08.02	Density Requirements	82
403.08.03	Tests for Compaction Control	83
403.08.04	Testing Services and Reports.....	83
403.08.05	Backfill Compliance Certificate.....	83
403.09.00	MANHOLES	83
403.09.01	Manholes - General	83
403.09.02	Manhole Bases.....	84
403.09.03	Connections.....	84

403.09.04	Benching	85
403.09.05	Steps	86
403.09.06	Manhole Frame Setting and Adjustments	86
403.10.00	CATCH BASINS.....	87
403.10.01	Single Barrel Catch Basins	87
403.10.02	Double Barrel Catch Basins.....	90
403.10.03	Twin Barrel Catch Basins.....	90
403.10.04	Catch Basins in Lanes.....	90
403.10.05	Catch Basins in Highway Swales or Ditches.....	90
403.10.06	Curb and Gutter.....	91
403.10.07	Catch Basin Leads.....	91
403.10.08	Concrete Drainage Swales	92
403.10.09	Catch Basin ICDs	93
403.11.00	CONCRETE	94
403.11.01	Concrete Formwork	94
403.11.02	Concrete Reinforcement.....	94
403.11.03	Structural Concrete.....	95
403.11.04	Ready-Mixed Concrete Equipment	96
403.11.05	Placing Concrete	100
403.11.06	Patching of New Concrete	104
403.11.07	Anchor Bolts and Dowels.....	104
403.11.08	Grouting.....	104
403.11.09	Construction Joints	105
403.11.10	Concrete Finishes.....	105
403.12.00	CLEAN UP	106
403.12.01	General.....	106
403.12.02	Sewer Cleaning	106
403.12.03	Temporary Flow Control	106
403.13.00	ACCEPTANCE TESTING	106
403.13.01	Acceptance Testing - General.....	106
403.13.02	Vertical/Horizontal Alignment Tolerances <i>for Manhole to Manhole Pipe Runs</i> ..	107
403.13.03	Infiltration / Exfiltration Limits	107
403.13.04	Deflection Testing.....	107
403.13.05	Image-Based Sewer Inspection	110
403.13.06	Manhole Inspection.....	117
403.13.07	Pressure Testing Procedure for HDPE Sanitary Sewer Forcemain Pipe.....	117
403.14.00	ABANDONMENT OF SEWER INFRASTRUCTURE.....	117
403.14.01	Abandonment of Sewer Infrastructure (Storm and Sanitary)	117
403.14.02	Abandonment of Manholes	118
403.14.03	Abandonment of Catch Basins.....	118
403.14.04	Abandonment of Other Storm or Sanitary Infrastructure	119
403.15.00	BIORETENTION SUBDRAIN SPECIFICATIONS	119

403.15.01 General.....	119
403.15.02 Materials.....	119
403.15.03 <i>Installation/Execution</i>	120
LIST OF STANDARD DRAWINGS.....	123-125

401.00.00 SCOPE

The *Standard Specifications Sewer Construction* forms part of the Contract Documents for all sewer mains, manholes, and sewer-related structures.

All work performed on existing sewer systems or on the installation of new sewer mains, manholes, services, and other sewer related appurtenances shall be done in accordance with these specifications, approved construction drawings, and the Manufacturer's Specifications. In case of any inconsistency or conflict between these documents, the provision of documents shall govern in the following order:

- 1) The Standard General Conditions
- 2) Standard Specifications Sewer Construction
- 3) The Manufacturer's Specifications

In these specifications, the term "Engineer" shall denote the Director, City of Calgary Water Resources, or his authorized representative. All deviations from these Specifications and the approved Construction Drawings shall have the written approval of the Engineer.

Note that inspection procedures and required notifications described in 401.01.00 and 401.02.00 Water Resources Inspection Numbers apply to new or existing City-owned sewer infrastructure, new subdivision projects and new private developments as outlined in the current edition of Development Site Servicing Plan (DSSP) Guidelines.

401.01.00 INSPECTION

The Engineer shall have free and uninterrupted access to any and all parts of the work area for the purpose of making inspections and taking samples of materials being used.

If any material, design or installation work does not conform to the following specifications (or specifications so noted on the approved construction drawings), the Engineer has the authority to stop work and order the removal of unsatisfactory materials or require work to be re-done to City Specifications.

Prior to commencement of any work on storm or sanitary sewers, the appropriate inspection section shall be contacted. Notification for each inspection request shall be given a minimum of forty-eight (48) hours in advance of the proposed work.

Failure to notify the appropriate inspection section will result in appropriate approvals being withheld until the Engineer has been satisfied that all work meets the standards set out under these specifications. Additional inspections recommended by the Engineer shall be the owner's responsibility.

401.02.00 WATER RESOURCES INSPECTION CONTACT

To make arrangement for required Inspections of water, sanitary, and stormwater infrastructure under Subdivision Agreements and Development/Indemnification Agreements contact Inspection Services by email at:

WaterUtilityInspections@Calgary.ca

When requesting an inspection, please provide the following information:

- 1) Requester's Contact Information*
- 2) Company represented*
- 3) Type of inspection required*
- 4) Location of work site (Subdivision phase/ Work Site address/location)*
- 5) Construction start date and time*
- 6) Type of Work to be inspected*

Note: A new Request for Inspection is required after 48 hours without construction activity, excluding Saturday, Sunday, and Holidays.

For inquiries regarding Inspection of City Contracts, please contact Capital Inspections Team Lead at (403) 813-3808.

401.03.00 UTILITY AND PIPELINE LOCATION NUMBERS

Prior to commencement of any work, the Contractor is responsible for contacting the appropriate agencies listed below to locate existing underground utilities and pipelines in or adjacent to the construction work site. The utility or pipeline agencies must be contacted two (2) working days prior to commencement of work.

401.03.01 Field Location Service Calls

ATCO	}	Alberta 1 st Call
Enmax		1-800-242-3447
Telus		www.alberta1call.com
Water Services		
Petrogas Processing Ltd.		
Home Oil Company Ltd.		
Imperial (Alberta Product Pipeline)		
Allstream Inc.		
Inter-Pipeline		
Shaw Cable		403-716-6035
Calgary Parks (Irrigation Lines)		403-268-1358 or 403-268-1381

401.03.02 Excavation Permits

Excavation Permits must be obtained from The City of Calgary Roads Business Unit prior to any excavation in public rights of way. **Permits can be obtained by applying online at: <https://ePermits.calgary.ca>.**

401.03.03 Emergency Service Calls

If you accidentally damage the coating or scrape, sever, or rupture any underground line, please call the appropriate emergency number immediately.

Watch for above ground structures such as utility pedestals, power lines and hydrants that are located in roadways, lanes and private property. If any of these are damaged, please report the incident immediately.

Emergency Calls - 24 Hour Service

ATCO.....	403-245-7222
Enmax.....	403-514-6100
Water Services.....	3-1-1
Calgary Roads.....	3-1-1
Telus.....	6-1-1
Shaw Cable.....	1-866-344-7429
Esso Pipeline Control Centre.....	1-800-372-9597
Inter-Pipeline.....	1-800-727-7163
Devon Canada Corporation (Home Oil Company Ltd.).....	403-264-9994

401.04.00 REFERENCES

The following regulations and standards are referred to within these specifications. In all cases, the most recent edition of these documents will govern.

401.04.01 Regulations

- Canadian Plumbing Code
- Explosives Act (Canada)
- Occupational Health and Safety Act, Regulation, and Code
- Alberta Fire Code
- City of Calgary Fire Prevention Bylaw
- City of Calgary Street Bylaw
- City of Calgary Drainage Bylaw
- City of Calgary Sewer Service Bylaw
- City of Calgary Utility Site Servicing Bylaw

401.04.02 Material and Installation Standards

The City of Calgary:

- Standard General Conditions
- Standard Specifications Waterworks Construction
- Standard Specifications Road Construction
- Standard Specifications Landscape Construction
- Erosion and Sediment Control Guidelines
- Design Guidelines for Subdivision Servicing
- Design Guidelines for Development Site Servicing Plans

Canadian Standards Association (CSA):

A23.1	Concrete Materials and Methods of Concrete Construction
A23.2	Methods of Test for Concrete
CAN/CSA A257.3	Joints for Circular Concrete Sewer and Culvert Pipe, Manhole Sections, and Fittings Using Rubber Gaskets
CAN/CSA A257.4	Precast Reinforced Circular Concrete Manhole Sections, Catch Basins, and Fittings
A3001	Cementitious Materials for Use in Concrete
B182.1	Plastic Drain and Sewer Pipe and Pipe Fittings
B182.2	PVC Sewer Pipe and Fittings (PSM Type)
B182.4	Profile PVC Sewer Pipe and Fittings
B182.6	Profile Polyethylene Sewer Pipe and Fittings for Leak-Proof Sewer Applications
B182.8	Profile Polyethylene Storm Sewer and Drainage Pipe and Fittings
CAN/CSA-G30.18	Billet Steel Bars for Concrete Reinforcement
B30.3	Cold Drawn Steel Wire for Concrete Reinforcement
B401	Corrugated Steel Pipe Products
CAN/CSA O86	Engineering Design in Wood
CAN/CSA S16	Limit States Design of Steel Structures
CAN/CSA S6	Canadian Highway Bridge Design Code
CAN3-S157	Strength Design in Aluminum
S269.1	False Work for Construction Purposes
S269.3	Concrete Formwork
W47.1	Certification of Companies for Fusion Welding of Steel Structures
W186	Welding of Reinforcing Bars in Reinforced Concrete Construction

American Society of Testing and Materials (ASTM):

A36/A36M	Carbon Structural Steel
A48/A48M	Gray Iron Castings
A53/A53M	Pipe Steel, Black and Hot-Dipped, Zinc-Coated, Welded and Seamless
A82/A82M	Superseded by ASTM 1064
A123	Zinc (Hot-Dipped Galvanized) Coatings on Iron and Steel Products
A148/A148M	Steel Castings, High Strength, for Structural Purposes
A185/A185M	Superseded by ASTM 1064
A496/A496M	Steel Wire, Deformed, for Concrete Reinforcement
A497/A497M	Steel Welded Wire Reinforcement, Deformed, for Concrete.
A536	Ductile Iron Castings
A775	Epoxy-Coated Steel Reinforcing Bars
A1064/A1064M	Carbon-Steel Wire and Welded Wire Reinforcement, Plain and Deformed for Concrete
C14/C14M	Concrete Sewer, Storm Drain, and Culvert Pipe
C31/C31M	Making and Curing Concrete Test Specimens in the Field
C33	Concrete Aggregates (Practice for)
C39/C39M	Compressive Strength of Cylindrical Concrete Specimens (Test Method for)
C76/C76M	Reinforced Concrete Culvert, Storm Drain, and Sewer Pipe.
C94/C94M	Ready-Mixed Concrete
C139	Concrete Masonry Units for Construction of Catch Basins and Manholes
C143/C143M	Slump of Hydraulic Cement Concrete (Test Method for).
C150	Portland Cement
C192/C192M	Making and Curing Concrete Test Specimens in the Laboratory (Practice for)
C231	Air Content of Freshly Mixed Concrete by the Pressure Method (Test Method for)
C260	Air-Entraining Admixtures for Concrete
C443/C443M	Joints for Concrete Pipe and Manholes, Using Rubber Gaskets
C478/C478M	Precast Reinforced Concrete Manhole Sections
C494	Chemical Admixtures for Concrete

C700	Vitrified Clay Pipe, Extra Strength, Standard Strength, and Perforated
C877	External Sealing Bands for Concrete Pipe, Manholes and Precast Box Sections
C990	Joints for Concrete Pipe, Manholes and Precast Box Sections Using Preformed Flexible Sealants
C923	Resilient Connectors between Reinforced Concrete Manhole Structure, pipes and laterals.
C1173	Standard Specification for Flexible Transition Couplings for Underground Piping Systems
C1417/C1417M	Manufacture of Reinforced Concrete Sewer, Storm Drain, and Culvert Pipe for Direct Design
C1433/C1433M	Precast Reinforced Concrete Box Sections for Culverts, Storm Drains, and Sewers
C1619	Elastomeric Seals for Joining Concrete Structures
C1677	Joints for Concrete Box, using Rubber Gaskets
D98	Calcium Chloride
D698	Laboratory Compaction Characteristics of Soil Using Standard Effort (12,400 ft-lbf/ft ³ (600 kN-m/m ³)) (Test Method for)
D1556	Density and Unit Weight of Soil in Place by the Sand-Cone Method (Test Method for)
D1784	Rigid PVC Compounds and CPVC Compounds
D2167	Density and Unit Weight of Soil in Place by the Rubber Balloon Method (Test Method for)
D2216	Laboratory Determination of Water (Moisture) Content of Soil and Rock by Mass (Test Method for)
D2321	Underground Installation of Thermoplastic Pipe for Sewers and Other Gravity-Flow Applications (Practice for)
D2487	Standard Classification of Soils for Engineering Purposes (Unified Soil Classification system)
D2922	Density of Soil and Soil-Aggregate in Place by Nuclear Methods (Shallow Depth) (Test Method for)
D3034	Type PSM Poly (Vinyl Chloride) (PVC) Sewer Pipe and Fittings
D3212	Standard Specification for Joints for Drain and Sewer Plastic Pipes Using Flexible Elastomeric Seals
D3350	Standard Specification for Polyethylene Plastics Pipe and Materials
D5397	Standard Test Method for Evaluation of Stress Crack Resistance of Polyolefin Geomembranes Using Notched Constant Tensile Load Test

D5926	Standard Specification for Poly (Vinyl Chloride) (PVC) Gaskets for Drain, Waste, and Vent (DMV), Sewer, Sanitary, and Storm Plumbing Systems
F477	Elastomeric Seals (Gaskets) for Joining Plastic Pipe
F714	Polyethylene (PE) Plastic Pipe (SDR-PR) Based on Outside Diameter
F794	Poly Vinyl Chloride (PVC) Profile Gravity Sewer Pipe and Fittings Based on Controlled Inside Diameter

American Concrete Institute (ACI):

315	Details and Detailing of Concrete Reinforcement
347	Recommended Practice for Concrete Formwork
SP.4	Formwork for Concrete

American Society of Civil Engineers (ASCE):

Standard Practice for Direct Design of Buried Precast Concrete Pipe Using Standard Installations (SIDDD), ASCE 15.

401.04.03 Acronyms

The following acronyms are used throughout these specifications:

- HDPE - High Density Polyethylene
- ICD - Inlet Control Device
- MR - Municipal Reserve
- PVC - Poly Vinyl Chloride
- R/W - Right-of-Way

401.05.00 REPORT SUBMISSIONS

The following is a list of reports that must be forwarded to the Engineer, and the locations in which they are referenced within these specifications.

Completed reports shall be sent to:

The City of Calgary
(Division Name and Mail Code listed below)
P.O. Box 2100, Station M
Calgary, AB T2P 2M5

Water Resources Infrastructure Delivery (Mail Code # 38) ***Attention: Inspection Services***

- 7) Concrete Testing Reports:
[402.09.04 Testing Requirements](#)
- 8) Additional testing on materials as requested by the Engineer
[403.03.01 Inspection - General](#)
- 9) Blasting Report and Approval Request
[403.02.03 Explosives and Blasting](#)
- 10) Acceptance Testing
[403.13.00 Acceptance Testing](#)

CALGARY ROADS (Mail Code # 71)

Attention: Senior Compaction Inspector, Geotechnical and Inspection Services

- 11) Backfill and Compaction Reports
[403.08.04 Testing Services and Reports](#)
- 12) Backfill Compliance Certificate
[403.08.05 Backfill Compliance Certificate](#)

402.00.00 MATERIALS

402.01.00 - APPROVED PRODUCTS LIST

402.01.01 Pipe

Non-Reinforced Concrete Pipe

Specifications and Standards - see [402.03.01 Concrete Pipe](#).

Approved Products:

Nominal Inside Pipe Diameter (mm)	Manufacturer/Supplier	
	Inland	Lafarge
300	Yes	No
375	Yes	No
450	Yes	No
525	Yes	No
600	Yes	No
675	No	No
750	No	No
900	No	No

Reinforced Concrete Pipe

Specifications and Standards - see [402.03.01 Concrete Pipe](#).

Approved Products:

Nominal Inside Pipe Diameter (mm)	Manufacturer/Supplier			
	Inland	Lafarge	Precon	Proform
300	Yes	Yes	No	No
375	Yes	Yes	No	No
450	Yes	Yes	No	No
525	Yes	Yes	No	No
600	Yes	Yes	No	Yes
675	Yes	Yes	No	No
750	Yes	Yes	No	Yes
900	Yes	Yes	No	No
1050	Yes	Yes	No	Yes
1200	Yes	Yes	Yes	Yes
1350	Yes	Yes	Yes	Yes
1500	Yes	Yes	Yes	Yes
1650	Yes	Yes	No	No
1800	Yes	Yes	No	No
1950	Yes	Yes	No	No
2100	Yes	Yes	No	No

Nominal Inside Pipe Diameter (mm)	Manufacturer/Supplier			
	Inland	Lafarge	Precon	Proform
2400	Yes	Yes	No	No
2700	Yes	Yes	No	No
3000	Yes	Yes	No	No

Reinforced Concrete Box

Specifications and Standards - see [402.03.02 Reinforced Concrete Box \(Duct\)](#).

Approved Products:

Dimensions (mm)	Manufacturer/Supplier		
	Inland	Lafarge	Proform
1200x900	Yes	Yes	Yes
1800x900	Yes	No	Yes
1800x1200	Yes	Yes	Yes
2400x1200	Yes	Yes	Yes
2400x1500	Yes	No	Yes
2400x1800	Yes	Yes	Yes
2400x2400	Yes	Yes	Yes
3000x1500	Yes	No	Yes
3000x2400	Yes	Yes	Yes
3600x3600	Yes	No	No

PVC Pipe

Specifications and Standards - see [402.03.03 PVC Pipe](#).

Approved Products:

PVC DR 35 Sewer Pipe (PSM Type) conforming to CSA-B182.2.

Minimum Pipe Stiffness 320 KPa.

Pipe Diameter (mm)	Manufacturer/Supplier				
	IPEX	IPEX Enviro-Tite	<i>Napco Royal</i>	Northern Pipe Products	NEXT Polymers
100 (perforated)	Yes	No	Yes	Yes	Yes
150 (perforated)	Yes	No	Yes	Yes	Yes
150	Yes	Yes	Yes	Yes	Yes
200	Yes	Yes	Yes	Yes	Yes
250	Yes	Yes	Yes	Yes	Yes
300	Yes	Yes	Yes	Yes	Yes
375	Yes	Yes	Yes	Yes	Yes
450	Yes	No	Yes	Yes	Yes

Pipe Diameter (mm)	Manufacturer/Supplier				
	IPEX	IPEX Enviro-Tite	<i>Napco Royal</i>	Northern Pipe Products	NEXT Polymers
525	Yes	No	Yes	No	No
600	Yes	No	Yes	No	No
675	Yes	No	Yes	No	No
750	Yes	No	Yes	No	No
900	Yes	No	Yes	No	No
1050	Yes	No	No	No	No
1200	Yes	No	No	No	No
1350	Yes	No	No	No	No
1500	Yes	No	No	No	No

PVC DR 28 Sewer Pipe (PSM Type) conforming to CSA-B182.2.

Minimum Pipe Stiffness 625 KPa.

Pipe Diameter (mm)	Manufacturer/Supplier				
	IPEX	IPEX Enviro-Tite	<i>Napco Royal</i>	Northern Pipe Products	NEXT Polymers
100	Yes	Yes	Yes	Yes	Yes
150	Yes	Yes	Yes	Yes	Yes

PVC Storm Sewer Service Pipe (PSM Type) conforming to CSAB182.1.

Minimum Pipe Stiffness 275 KPa.

Pipe Diameter (mm)	Manufacturer/Supplier		
	IPEX	<i>Napco Royal</i>	NEXT Polymers
75	Yes	Yes	Yes

PVC Profile Pipe

Specifications and Standards - see [402.03.05 Profile Pipe](#).

Approved Products:

Profile PVC PS 320 conforming to CSA-B182.4M. Pipe Stiffness 320 KPa.

Pipe Diameter (mm)	Manufacturer/Supplier		
	IPEX Ultra-Rib Pipe	IPEX Ultra -X2	<i>Napco Royal</i> (Kor-Flo Pipe)
200	Yes	No	Yes
250	Yes	No	Yes
300	Yes	No	Yes
375	Yes	No	Yes

Pipe Diameter (mm)	Manufacturer/Supplier		
	IPEX Ultra-Rib Pipe	IPEX Ultra -X2	Napco Royal (Kor-Flo Pipe)
450	Yes	No	Yes
525	Yes	No	Yes
600	Yes	No	Yes
750	No	Yes	Yes
900	No	Yes	Yes

Polypropylene Pipe

Specifications and Standards - see [402.03.05 Polypropylene Profile Pipe](#)

Approved Products:

Polypropylene profile pipe conforming to CSA B182.13 as supplied by Advanced Drainage Systems (ADS Canada)

SaniTite HP Dual-wall	300 mm to 750 mm
SaniTite HP Triple-wall	750 mm to 1050 mm
	1200 mm to 1500 mm accepted on a case-by-case basis only*

*Approval required from Development Approvals, Water Resources

HDPE Pipe

Specifications and Standards - see [402.03.06 HDPE Pipe](#).

Approved for service leads using pipe bursting for sanitary sewer forcemain applications.

Approved Products:

Driscoplex by CP Chemical Performance Pipe, KWH Sclairpipe, PolyPipe by CS Rinker, WL Plastics, Flint Global Poly, or an approved equal. Electro-fusion fittings and processors shall be Friatec, Central Plastics, Tega, Elofit or an approved equal.

Corrugated Steel Pipe / Structural Plate Corrugated Steel Pipe

Specifications and Standards - see [402.03.04 Corrugated Steel Pipe](#).

All CSP and SPCSP shall be supplied and fabricated by a fabricator certified to CSA G401. Certification shall be completed by an independent agency accredited by the Standards Council of Canada.

402.01.02 Sewer Pipe Joints and Fittings

Concrete Box Conduit (Duct) Joints

Specifications and Standards - see [402.04.04 Concrete Duct Joints](#) and Table below:

All sealing products and chemicals (or approved equal) must conform to the latest applicable specifications and shall be installed according to Manufacturer's instructions.

Option	Description	ASTM/ CSA	Approved Products
1	Butyl rubber sealant or Preformed flexible sealant	C990 C972 C765	KentSeal, Press-Seal EZ-STIK or PRO-STIK, ConSeal CS- 202
2	Rubber gasket	C443 C1619 Class E C1677 Class E	HK Tylox SuperSeal, Press- Seal 4G or Pre-lubricated RFS
3a	Expanding (hydrophilic) waterstop-extrudable form		SikaSwell S-2, DeNeef SwellSeal SealBoss SwellCaulk, SPetec WT400
3b	Expanding (hydrophilic) waterstop-rope/strip form		ConSeal CS-231, DeNeef SwellSeal SealBoss SwellTape
4	Geotextile filter fabric		270R Non-Woven
5	External sealing band	C877 Type III	Press-Seal EZ Wrap, ConSeal CS-212
6	Waterproofing membrane or coating		Bituthene 3000, MEL-ROL, Blueskin WP200
7	Elastomeric sealant	C920	Sikaflex

Fabricated and Injection Molded Fittings for PVC Sewer Pipe

Specifications and Standards - see [402.04.05 Fabricated and Injection Molded Fittings and Couplings for PVC Sewer Pipe](#).

Approved Products:

Pipe	Fitting	Manufacturer/Supplier
Smooth Wall DR 35 & DR 28	Bends, Wyes Tees and Inserta Tees (only for mains 375 mm and larger)	Galaxy Plastics - Tigre, IPEX Inc., Inserta, Napco Royal , G.P.K. Products, Pro-Line Fittings Inc., or approved equal

Pipe	Fitting	Manufacturer/Supplier
Smooth Wall DR35 & DR 28	100 mm x100mm Gasketed Repair Coupling 100 mm x 75 mm Reducer Coupling ^A 100 mm Spigot Plug 100 mm Gasketed Cap 100 mm 22.5° Bends (regular & extra-long), (GxS & GxG), 100mm Wyes ^B & 100 mm Tees ^B	Napco Royal , Galaxy Plastics - Tigre, IPEX Inc., G.P.K. Products, Pro-Line Fittings Inc.

^A Only for connecting 75 mm service to main using Inserta Tee with gasketed bell section.

^B Only to install external cleanouts and a limited number of bends can be used for each service connection.

Specifications and Standards - see [402.01.04 Service Connectors](#) for service connections.

Specifications and Standards – see [402.01.05 Manhole Connections](#) for manhole connections

Fabricated and Injection Molded Fittings for PVC Profile Pipe

Specifications and Standards - see [402.04.05 Fabricated and Injection Molded Fittings Couplings for PVC Sewer Pipe](#).

Approved Products:

Pipe	Fitting	Manufacturer/Supplier
Profile PVC Sewer Pipe (PS 320) ^D	Bends, Wyes Tees and Inserta Tees ^C	Galaxy Plastics, IPEX Inc., Inserta, Napco Royal , G.P.K., Pro-Line Fittings Inc., or approved equal

^C Only for mains 250 mm service and larger.

^D Storm Sewer Construction only.

Please see [402.01.05 Manhole Connections](#) for manhole connections.

Gaskets

Specifications and Standards - see [402.04.01 Gaskets](#)

PVC Pipe - Gaskets shall be supplied by the pipe manufacturer.

Concrete Pipe - Rubber gaskets shall be supplied by the pipe manufacturer.

Couplings for PVC Pipe

Specifications and Standards - see [402.04.05 Fabricated and Injection Molded Fittings and Couplings for PVC Pipe](#).

Approved Products:

Coupling	Manufacturer/Supplier
Fernco Flexible Coupling	Spectrum Sales Agency
Fernco RC Coupling (Armoured)	Spectrum Sales Agency

Coupling	Manufacturer/Supplier
Rollee Swift Flexible Coupling	Rollee Industrial Products Ltd.
Flex-Seal Standard Rubber Coupling	Mission Rubber/ Vantage Marketing Inc.
Flex-Seal Adjustable Repair Coupling (ARC)	Mission Rubber/ Vantage Marketing Inc.
Flexible PVC Pipe Coupling	Dallas Specialty
Maxadaptor Coupling	MaxAdaptor

Mortar

Specifications and Standards - see: [402.04.02 Mortar](#).

Chemrex Thoroc Plug or approved equal

Sewer Pipe Plugs

Specifications and Standards - see [402.04.03 Sewer Pipe Plugs](#).

Sewer plugs shall be supplied by the pipe manufacturer and shall be compatible with the pipe joint.

Crack and Joint Seal Repair Chemicals and Compounds

All polyurethane sealing chemicals for repair of concrete joints/cracks must conform to the latest applicable specifications and be installed according to manufacturer's instructions. Chemical sealants shall be applied by an industry certified applicator or manufacturer trained personnel. Proof of training certification is required.

Product Name	Manufacturer	Manufacturer/Supplier
Flex LV	De Neef Construction Chemicals	Cascade Aqua-Tech
CFL PURE	De Neef Construction Chemicals	Cascade Aqua-Tech
Cut	De Neef Construction Chemicals	Cascade Aqua-Tech
Prime-Flex 900 XLV Hydrophilic Grout*	Prime Resins	Martech
Prime-Flex 920 Hydrophobic Grout*	Prime Resins	Martech
Hyperflex Grout	Seal Guard	Spectrum Sales
Sealguard II Dual Component Grout	Seal Guard	Spectrum Sales
1510 Hydrophobic Grout	Sealboss Corp.	Cascade Aqua-Tech

Product Name	Manufacturer	Manufacturer/Supplier
1570 Hydrophobic Grout	Sealboss Corp.	Cascade Aqua-Tech
Flexgel 2 Hydrophilic Grout	Sealboss Corp.	Cascade Aqua-Tech
AP 500 Hydrophilic Grout	Alchemy- Spetec	Brock-White
AP 700 Hydrophobic Grout	Alchemy- Spetec	Brock-White

402.01.03 Casing Spacers

Casing Spacers for Carrier and Encasement Pipe

Specifications and Standards – see [402.04.06 Casing Spacers for Carrier and Encasement Pipe](#).

Approved Products:

Nominal Carrier Pipe Diameter	Spacer Length (Minimum)	Runner Width (Minimum)	Manufacturer/ Supplier	Type/Model
150–600 mm	200 mm	25 mm	BWM	SS-8
			APS	SSI-8
			CCI/Pipeline Supply International	CSS8
			Silvertip/Martech	SSBM8
600–1200 mm	300 mm	50 mm	BWM	SS-12
			APS	SSI-12
			CCI/Pipeline Supply International	CSS12
			Silvertip/Martech	SSBM12

- **Carrier pipe 750mm and larger shall be installed with ApogeeAero Roller casing spacers by Advance Products or an approved equal to prevent rifling during installation**
- The skid height shall be at least 10 mm > than the bell height.
- Non-metallic casing spacers (RACI and PSI) are permitted on a case-by-case basis only. Job-specific City of Calgary approval is required.

Carrier Pipe Nominal Inside Diameter (mm)	Encasement Pipe Minimum Nominal Diameter (mm)	
	PVC or Steel	Concrete
150	300	300
200	400	450
250	450	500
300	500	600
375	660	710

Carrier Pipe Nominal Inside Diameter (mm)	Encasement Pipe Minimum Nominal Diameter (mm)	
	PVC or Steel	Concrete
450	750	810
525	810	910
600	865	1015
675	965	1115
750	1220	1220
900	1270	1420
1050	1320	1575
1200*	1370	1625

* Carrier pipes greater than 1200 mm require approval by the Engineer.

End Seals for Encased Pipe

Specifications and Standards - End seals shall conform to standards ASTM D297, D395, D412, D2240, and form a seal between casing and encased pipe as per **Sheet 16: Standard Specification Waterworks Construction**.

Approved Products:

Type/Model	Manufacturer/Supplier
Innerlynx End Seal	Advance Products and Systems
Link Seal	PSI Products
Pipe Seal	Flexicraft
Pipe Seal	BWN

402.01.04 Services

Service Lead Pipes

Specifications and Standards – see [402.05.01 Service Leads](#).

Approved Products:

Type of Lead	Diameter (mm)	Manufacturer/Supplier
Non-Reinforced Concrete	300	Inland
Reinforced Concrete	300 & 375	Inland, Lafarge
PVC - DR 28	100 & 150	IPEX, Napco Royal , NEXT Polymers
PVC - DR 35	150, 200, 250, 300, & 375	IPEX, Napco Royal , NEXT Polymers
PVC - CSA B 182.1M	75 mm solid (weeping tile service only)	IPEX, Napco Royal
PE- DR 17*	100 & 150	Driscoplex by CP Chemical Performance Pipe, KWH Sclairpipe, PolyPipe by CS Rinker

*HDPE pipe is to be used only for pipe bursting **or sewer force mains where approved** (see [402.03.06 HDPE Pipe](#)).

Service Lead Jointing Material

Specifications and Standards – see [402.05.02 Service Lead Jointing Material](#).

Approved Products:

Type of Lead	Material	Manufacturer/Supplier
Non-Reinforced Concrete	Gasket	Inland
Reinforced Concrete	Gasket	Inland, Lafarge
PVC - DR 28	Gasket	IPEX, Napco Royal , NEXT Polymers, Pro-Line Fittings Inc.
PVC - DR 35	Gasket	IPEX, Napco Royal , NEXT Polymers , Pro-Line Fittings Inc.
PVC (75 mm)	CSA B182.1M Solvent Weld	

Service Lead Bends, Adapters and Fittings

Specifications and Standards – see [402.05.03 Service Lead Bends, Adaptors, Fittings and Connectors](#).

Approved Products:

All bends, adapters and fittings shall be supplied by either the service lead Manufacturer or by third parties approved by the Engineer.

Service Connectors

Specifications and Standards – see [402.05.03 Service Lead Bends, Adaptors, Fittings and Connectors](#)

Approved Connector Products:

Type of Sewer Main	Approved Connectors	Manufacturer/Supplier
PVC	Strap-on Saddle-Tee or Wye	IPEX Inc., Multi Fittings Inc., Tigre, Galaxy Plastics (distributor of Tigre), G.P.K. Products, Pro-Line Fittings Inc., Napco Royal
	FAT BOY Inserta Tee (only for mains 375 mm or larger)	Napco Royal , Pro-Line Fittings Inc.
	EZ Tee - Inserta Tee (only for mains 375 mm or larger)	Galaxy Plastics Ltd.
	Inserta Tee (only for mains 375 mm or larger)	Inserta Fittings Co., Pro-Line Fittings Inc.

Type of Sewer Main	Approved Connectors	Manufacturer/Supplier
	Inline Tee or Wye	Galaxy Plastics Ltd., IPEX Inc. Napco Royal
Profile PVC	FAT BOY Inserta Tee (only for mains 250 mm or larger)	Napco Royal, Pro-Line Fittings Inc.
	EZ Tee - Inserta Tee (only for mains 250 mm or larger)	Galaxy Plastics Ltd.
	Inserta Tee (only for mains 250 mm or larger)	Inserta Fittings Co., Pro-Line Fittings Inc.
Concrete	Strap-on Saddle-Tee or Wye	IPEX Inc., Multi Fittings Inc., Tigre, Galaxy Plastics (distributor of Tigre), G.P.K. Products, Pro-Line Fittings Inc.
	Flexible Saddle*	Mission Rubber Co.
	Core-Bell Concrete Adapter (only for mains 450 mm or larger)	Galaxy Plastics Ltd.
	Tapping Adapter (Kipper)	Multi Fittings Inc.
	TwisTee	Mission Rubber Co.
	PVC Bell Connector	As per 402.01.01 PVC Pipe.
Asbestos Cement	Strap on Saddle-Tee or Wye	IPEX Inc., Multi Fittings Inc., Tigre, Galaxy Plastics (distributor of Tigre), G.P.K. Products, Pro-Line Fittings Inc.
	Flexible Saddle*	Mission Rubber Co.
	PVC Bell Connector	As per 402.01.01 PVC Pipe.
Clay Tile	Strap on Saddle-Tee or Wye	IPEX Inc., Multi Fittings Inc., Tigre, Galaxy Plastics (distributor of Tigre), G.P.K. Products, Pro-Line Fittings Inc.
	Tapping Adapter (Kipper)	Multi Fittings Inc.
	Flexible Saddle*	Mission Rubber Co.

***Note: Flexible strap on Saddle by Mission Rubber for emergency repair of existing sanitary connections on concrete, asbestos concrete or clay tile where existing core hole cannot be accommodated by rigid-strap on saddle only.**

Connector Sealant

Specifications and Standards – see [402.05.04 Connector Sealants](#).

Approved Products:

Approved Sealants for Bonding PVC spigot adapter (Kipper) to cored hole in Concrete or Clay tile sewer mains:

Sealant	Manufacturer/Supplier	Ambient Temperature
Trempro 626	Tremco	4°C - 27°C
Permaseal HV	Chemtron	20°C - 40°C

402.01.05 Manholes

Manhole Covers

Specifications and Standards – see [402.06.01 Manholes - General](#)

Approved Products:

Type of Cover	Manufacturer/Supplier
Standard Manhole Cover Drawing 1: Wastewater Manhole Cover Drawing 1A: Storm Manhole Cover Drawing 1B: Maximum Access Frame	Sigma Corporation, Sovereign Castings, Trojan Industries, Westview Sales, or approved equal
Standard Manhole Frame Locking Cover Drawing 1C: Manhole Frame Locking Cover	McGard DuraShield*
Grated Manhole Cover Drawing 2: Grated Manhole Cover	Norwood Foundry, Sigma Corporation, Sovereign Castings, Trojan Industries, Westview Sales, or approved equal

*** Locking cover to be supplied by and installed at Water Services / Field Services direction only.**

Manhole Frames

Specifications and Standards – see [402.06.01 Manholes - General](#)

Approved Products:

Type of Frame	Manufacturer/Supplier
Standard Manhole Frame Drawing 4: Standard Manhole Frame	Norwood Foundry, Sigma Corporation, Sovereign Castings, Trojan Industries, Westview Sales, or approved equal
90 mm Shallow Manhole Frame Drawing 4A: 90 mm Shallow Manhole Frame	Norwood Foundry, Sovereign Castings, Trojan Industries, Westview Sales, or approved equal
150 mm Shallow Manhole Frame Drawing 5: 150 mm Shallow Manhole Frame	Norwood Foundry, Sigma Corporation, Sovereign Castings, Trojan Industries, Westview Sales, or approved equal
Manhole Frame Safety Grating Drawing 5A: Manhole Frame Safety Grating	Norwood Foundry, Sovereign Castings, Trojan Industries, Westview Sales, or approved equal

Type of Frame	Manufacturer/Supplier
Manhole Frame Riser* Drawing 3: Manhole Frame Riser	Norwood Foundry, Sovereign Castings, Trojan Industries, Westview Sales, or approved equal
Adjustable Manhole Frame	Trojan Industries Inc. or approved equal

* Only permitted for re-surfacing on existing roads with City approval. Not to be used for new construction.

Manhole Collars

Specifications and Standards – see [402.06.01 Manholes - General](#).

Approved Products - Precast Manhole Collars ([Drawing 6: Precast Manhole Collar](#)):

Height (mm)	Manufacturer/Supplier			
	Inland	Lafarge	Precon	Proform
50	Yes	Yes	Yes	Yes
75	Yes	Yes	Yes	Yes
100	Yes	Yes	Yes	Yes
150	Yes	Yes	Yes	Yes
200	Yes	Yes	No	No

Manhole Slab Tops

Specifications and Standards – see [402.06.01 Manholes - General](#).

Approved Products:

Type of Slab Top	Manufacturer/Supplier
Manhole Slab Top Drawing 7: Manhole Slab Top	Inland, Lafarge, Precon
Manhole Slab Top for Spigot-Up Installations Drawing 7A: Slab Top Detail for Spigot-Up Installations	Inland, Lafarge, Proform, Precon
Manhole Slab Top for Large Diameter Round Manhole Drawing 18A: Large Diameter Manholes 1500 & 1800	Inland, Lafarge, Proform, Precon

Manhole Risers (Barrels)

Specifications and Standards – see [402.06.01 Manholes - General](#)

Approved Products:

Manhole Risers ([Drawing 8: Manhole Risers \(Barrels\)](#))

Height (mm)	Manufacturer/Supplier		
	Inland	Lafarge	Precon
300	Yes	Yes	Yes
400	Yes	Yes	Yes
800	Yes	Yes	Yes
1200	Yes	Yes	Yes

1600	No	No	No
2000	Yes	No	Yes
2440	Yes (2500 mm)	Yes	No

Manhole Risers for Spigot-Up Installations ([Drawing 8A: Manhole Risers \(Barrels\) Spigot-Up Installation](#)).

Height (mm)	Manufacturer/Supplier			
	Proform	Inland	Lafarge	Precon
300	Yes	Yes	Yes	Yes
400	Yes	Yes	Yes	Yes
800	Yes	Yes	Yes	Yes
1200	Yes	Yes	Yes	Yes
1600	Yes	No	No	Yes
2000	Yes	Yes	No	Yes
2440	Yes	Yes (2500 mm)	Yes	No

Manhole Adaptor Barrels

Specifications and Standards – see [402.06.01 Manholes - General](#)

Approved Products:

Type of Adaptor	Manufacturer/Supplier	Height (mm)
Spigot-Spigot Adaptor Drawing 8B: Manhole Adaptors Spigot-Spigot/Bell-Bell	Inland	184
	Lafarge	305
	Proform	305
Bell-Bell Adaptor Drawing 8B: Manhole Adaptors Spigot-Spigot/Bell-Bell	Inland	508
	Lafarge	406
	Proform	406

Manhole Steps

Specifications and Standards – see [402.06.03 Manhole Steps, Drawing 9: Manhole Steps](#))

Approved Products:

Type of Step	Manufacturer/Supplier
Aluminum Manhole Step*	MSU Mississauga Ltd Model 350
Polyethylene Coated Aluminum Manhole Step	MSU Mississauga Ltd Model 360
Stainless Steel 316 Manhole Step	MSU Mississauga Ltd Model 380
Galvanized Steel	Inland, Lafarge, Precon, Proform

Steel Reinforced Polypropylene Step (installed according to manufacturer's instructions)	Lane International Corporation Model P12850
---	---

***Aluminum steps are to be used only in the manufacturing stage of manhole products. For all field installations and structures subject to potential submersion in water, Polyethylene Coated Aluminum Steps are to be used.**

Manholes

Specifications and Standards – see [402.06.01 Manholes - General](#)

Approved Products:

Precast Type 1-S Manhole

([Drawing 18: Precast Type '1-S' Manhole & Assembly](#)).

Dimensions (mm x mm)	Inland	Lafarge	Precon	Proform
1220 x 1220	Yes	Yes	Yes	Yes
1500 x 1500	No	Yes	No	No
1525 x 1525	Yes	No	Yes	Yes
1830 x 1830	Yes	No	Yes	Yes
1830 x 2440	No	No	Yes	No
1930 x 1930	No	Yes	No	No
1980 x 1980	Yes	No	No	No
2135 x 2135	No	No	No	Yes
2400 x 2400	No	Yes	No	No
2440 x 2440	Yes	No	No	Yes
2440 x 3050	No	No	No	Yes
2500 x 3000	No	No	Yes	No
2660 x 3660	No	No	No	Yes
2745 x 2745	No	No	No	Yes
2800 x 2800	Yes	Yes	No	No
3000 x 4000	No	No	Yes	No
3050 x 3050	No	No	No	Yes

Precast T-Riser Manhole

([Drawing 12: T-Riser Manhole and Drawing 12A: 1050 T-Riser Manhole](#))

Pipe Diameter (mm)	Manufacturer/Supplier	
	Inland	Lafarge
1050	Yes	No
1200	Yes	Yes
1350	Yes	Yes
1500	Yes	Yes

Pipe Diameter (mm)	Manufacturer/Supplier	
	Inland	Lafarge
1650	Yes	Yes
1800	Yes	Yes
1950	Yes	Yes
2100	Yes	Yes
2400	Yes	Yes
2700	Yes	Yes
3000	Yes	Yes

Large Diameter Manholes

[\(Drawing 18A: Large Diameter Manholes 1500 to 3000\)](#)

Vault Diameter (mm)	Manufacturer/Supplier			
	Inland	Precon	Proform	Lafarge
1500	Yes	Yes	Yes	Yes
1800	Yes	Yes	Yes	Yes
2400	Yes	Yes	No	Yes
3000	Yes	Yes	No	Yes

Field Cast and Control (Test) Manholes

Type of Manhole
Type 5A - Exterior Drop Drawing 14: Exterior Drop Manhole
Type 5A - Interior Drop Drawing 15: Type 5'A' Interior Drop Manhole
Type 5A - Box Conduit (Box) Drawing 16: Standard 5'A' Manhole For Box Conduit (Duct)
Type 1 Drawing 17: Cast-In Place Standard Type "1" Manhole
Test Manhole Drawing 19: Control Manhole (Test Manhole)
Precon Test Manhole - Pre-benched Drawing 19: Control Manhole (Test Manhole)
Skimming Manhole Drawing 20: Skimming Manhole Base

Manhole Bases

Specifications and Standards – see [402.06.01 Manholes - General](#)

Approved Products:

Type of Base	Manufacturer /Supplier
Type 5A Drawing 10: Precast Manhole Base Type 5 'A'	Inland
	Lafarge
	Precon
Type 5A: Spigot-Up Installations Drawing 10a: Precast Manhole Base Type 5'A' For Spigot-Up Installations	Inland
	Lafarge
	Precon
Type 5A: Spigot-Up Installations Drawing 11: Precast Octagonal Manhole Base Type 5'A'	Proform (octagonal)
Type 5A: Pre-Benched Spigot Up Monolithic Manhole Drawing 38B: 5A Manhole Assembly For Spigot-Up Installations	Inland
	Lafarge
	Precon
	Proform
Type 5A Drawing 13: Field Cast Manhole Base Type 5'A'	
Skimming Manhole Drawing 20: Skimming Manhole Base	

*Note: All pre-benched bases may be supplied with either ½ or ¾ benched channels

Manhole Connections

Specifications and Standards – see [402.06.01 Manholes - General](#).

Rubber Gaskets for connecting **Flexible Pipe** to Manholes and Catch Basins.

Manufacturer/Supplier	Integral Gasket	Gasket
Press-Seal Corporation	EconoSeal Cast-a-Seal 603 Cast-a-Seal 802	Kwik Seal
Press-Seal Corporation	PSX: Direct Drive	PSX: Direct Drive
Hamilton Kent	-	Cobra Style
Hamilton Kent	-	Adjustable Style
A-Lok Products Inc.	A-Lok Premium	-
A-Lok	Mortared in field cuts	Water-Stop
Press-Seal Corporation	Mortared in field cuts	WS-30 Waterstop

Manhole Connector for Ultrarib PVC pipe (storm sewer only).

Pipe	Fitting	Manufacturer/Supplier
Ultrarib PVC Pipe Connections to Manholes (B x DR35)	Manhole Connector	IPEX Inc.

Manhole Barrel Jointing Material

Specifications and Standards – see [402.06.02 Manhole Barrel Jointing Material](#).

Approved Products:

Material supplied or recommended by the manufacturer and approved by the Engineer shall be used on each barrel joint.

Approved Material	Manufacturer/Supplier
Rubber Gasket	Concrete Pipe Plants
Rub'r-Nek	Henry Company
Kent Seal	Hamilton Kent
<i>Pro-Stik & EZ-Stik</i>	<i>Press Seal Corporation</i>

Mortar

Specifications and Standards – see [402.06.04 Mortar](#)

Approved Products:

Product Name	Manufacturer	Manufacturer/Supplier
ThoRoc Plug	ChemRex	Mountainview Systems

402.01.06 Catch Basins

Catch Basin Side Inlets

Specifications and Standards – see [402.07.01 Catch Basins - General](#)

Approved Products:

Type of Side Inlet	Manufacturer/Supplier
Side Inlet Type 'C' Drawing 21: Catch Basin Side Inlet Type 'C'	Norwood Foundry, Sovereign Castings, Trojan Industries, Westview Sales
Two Piece Side Inlet Type 'C' * Drawing 21A: Two Piece Catch Basin Side Inlet Type "C"	Sovereign Castings Inc., Trojan Ind. Inc., Westview Sales Ltd.

*Note: Two Piece Side Inlet Type 'C' are required on all freeways, major roads, collector roads, bus routes, and any road where snow clearing occurs.

Catch Basin Grates

Specifications and Standards – see [402.07.01 Catch Basins - General](#)

Approved Product:

Type of Grate	Manufacturer/Supplier
Type 'C' Grate* Drawing 22: Catch Basin Grate Type 'C'	Norwood Foundry, Sovereign Castings, Trojan Industries, Westview Sales

Type 'K-2' Grate Drawing 23: Catch Basin Grate Type 'K-2'	Norwood Foundry, Sovereign Castings, Trojan Industries, Westview Sales
--	---

*Note: Type K-3 catch basin utilizes a Type 'C' grate.

Catch Basin Frames

Specifications and Standards – see [402.07.01 Catch Basins - General](#)

Approved Products:

Type of Frame	Manufacturer/Supplier
Type 'C' Frame* Drawing 24: Catch Basin Frame Type 'C'	Norwood Foundry, Sovereign Castings, Trojan Industries, Westview Sales
Type 'K-2' Frame Drawing 25: Catch Basin Frame Type 'K-2'	Norwood Foundry, Sovereign Castings, Trojan Industries, Westview Sales

*Note: Type K-3 catch basin utilizes a Type 'C' frame.

Catch Basin Tops

Specifications and Standards – see [402.07.01 Catch Basins - General](#),

Approved Products:

Types of Top	Manufacturer
Precast Top for Type 'C' Catch Basin Drawing 26: Precast Top For Type 'C' Catch Basin	Inland
	Lafarge
	Proform
	Precon
Alternate Precast Top for Type 'C' Catch Basin in Low Profile Rolled Curb Drawing 27: Alternate Precast Top for Type 'C' Catch Basin	Inland
	Lafarge
Precast Slab Top for Type 'K-2' Catch Basin Drawing 28: Precast Slab Top for Type 'K-2' Catch Basin	Inland
	Lafarge
	Proform
	Precon
Precast Slab Top for Type 'K-3' Catch Basin Drawing 29: Precast Slab Top for Type 'K-3' Catch Basin	Inland
	Lafarge
	Proform
	Precon

Catch Basin Collars

Specifications and Standards – see [402.07.01 Catch Basins - General](#)

Approved Products:

Types of Collar	Manufacturer/ Supplier
Concrete Catch Basin Collar for Type 'K-3' Catch Basin Drawing 29A: Concrete CB Collar For K-3 Catch Basin	Lafarge (67 mm)
	Proform (50,75,100,150 mm)
Precast Collar for Type 'K-2' Catch Basin Drawing 30: Precast Collar For Type 'K-2' Catch Basin	Inland (100 mm)
	Proform (50, 75, 100 mm)

Spigot-Up/Plain end Catch Basin Barrels

Specifications and Standards – see:

[402.07.01 Catch Basins - General](#), [Drawing 31: Catch Basin Precast Barrel](#)

Approved Products:

Height (mm)	Manufacturer/Supplier			
	Inland	Lafarge	Proform	Precon
150	Yes	Yes (152 mm)	No	No
300	Yes	Yes (305 mm)	No	No
450	Yes	Yes (457 mm)	No	No
600	Yes	Yes (610 mm)	No	Yes
762	No	Yes	No	No
914	No	Yes	No	No
1050	Yes	Yes (1067mm)	Yes (1067mm)	Yes (1000mm)

***Note: Plain end catch basin barrels accepted at Engineer's discretion**

Catch Basin Bases

Specifications and Standards – see [402.07.01 Catch Basins - General](#)

Approved Products:

Type	Manufacturer/ Supplier
Precast Monolithic Catch Basin Base Drawing 31a: Precast Monolithic Catch Basin Base	Inland
	Lafarge
	Proform
900 mm Monolithic Catch Basin (Schlusselbauer Process)	Inland

Catch Basin Leads

Specifications and Standards – see:

[402.03.01 Concrete Pipe](#) for concrete pipe.

[402.03.03 PVC Pipe](#) for solid wall PVC pipe.

[402.03.05 Profile Pipe](#) for profile PVC pipe.

Approved Products:

Catch Basin Type	Size of Lead (mm)	Material	Manufacturer/Supplier
Single Catch Basin	250	PVC	IPEX, Napco Royal Flex-Lox, NEXT Polymers
		Profile PVC	IPEX Ultrarib*, Napco Royal Pipe Kor Flo
Double Catch Basin	300	PVC	IPEX, Napco Royal Flex-Lox, NEXT Polymers
		Reinforced Concrete	Lafarge, Inland
		Profile PVC	IPEX Ultrarib*, Napco Royal Pipe Kor Flo
Interconnected Catch Basin	300	PVC	IPEX, Napco Royal Flex-Lox, NEXT Polymers
		Reinforced Concrete	Lafarge, Inland
		Profile PVC	IPEX Ultrarib*, Napco Royal Pipe Kor Flo

ICDs

Approved Products:

Type of ICD	Size (mm)	Manufacturer/Supplier
Curved Plate Drawing 43B: Catch Basin Inlet Control Assembly for Plate Type Control	R30	PVC - IPEX, Pro-Line Fittings, Galaxy Plastics Stainless, Napco Royal Steel – Lafarge, Inland , Precon , Proform
	R50	
	R70	
	R100	
Flat Plate Drawing 31A: Precast Monolithic Catch Basin Base or Drawing 43B: Catch Basin Inlet Control Assembly for Plate Type Control	R30	PVC - IPEX, Pro-Line Fittings, Galaxy Plastics Stainless , Napco Royal Steel – Lafarge, Inland , Precon , Proform
	R50	
	R70	
	R100	

***Note: ICD material to be 6 mm gauge PVC/fiberglass or ¼” 304 stainless steel**

402.01.07 Warning Tape

Specifications and Standards – [402.10.03 Warning Tape](#)

Approved Products:

Manufacturer/Supplier	Type/Model
ACP International	MTP 61000*

Empire	Magnatec
Pro-line Safety Products*	10314 XXX 3

*Or approved equal

402.01.08 Oil-Grit Separators and Oil-Water Interceptor

All Interceptors shall meet the current requirements of the **Stormwater Management and Design Manual**.

Performance: An average annual Total Suspended Solids (TSS) removal rate of 85% for particle sizes 50 µm and greater is required for each year of the period of record. Calculations and information showing how removal rates were achieved or modeled must be submitted to Development Approvals at the design stage.

Approved Products:

Type of Oil-Grit Separator	Manufacturer/Supplier
Stormceptor	Imbrium Systems, LaFarge
Vortechs	CONTECH Stormwater Solutions
CDS	CONTECH Stormwater Solutions, Rainwater Management
First Defense	Hydro International, Armtec
AFC (Oil-Water Interceptor)	American Forcecrete of Canada
Hydrostorm , Hydroguard	Precon

*Catch basin-types of Oil-Grit Separators are not approved

402.02.00 GENERAL

Materials must conform to standards set out in the Standard Specifications Sewer Construction. Materials not listed may be acceptable on a case by case basis; however, prior approval by The City of Calgary will be required.

Upon request by Water Resources, evidence shall be provided that material complies with these standard specifications. Access to manufacturing facilities for inspection purposes shall also be provided if requested by Water Resources.

Manufacturers producing and supplying precast concrete components for pipe, manholes, box culverts and catch basins shall be compliant under certification program administered by Canadian Precast Concrete Quality Assurance (CPCQA). Copies of Prequalification Certificates shall be submitted to Water Resources every May 1 of the current year. It is the manufacturer's responsibility to notify Water Resources within five (5) business days of any change in status of their prequalification certificate.

402.03.00 SEWER PIPE

402.03.01 Concrete Pipe

Concrete sewer pipe used in sewer construction shall be manufactured from sulphate resistant cement Type HS (Type 50) in accordance with CSA A3001 or Type V in accordance with ASTM C150. All concrete structures shall be designed for CL-800 truck

loading as per CSA-S6-00 (Canadian Highway Bridge Design Code).

Round pipe 3.0m in diameter and larger or box pipe 3.0m in height and larger shall be produced with approved integral fall arrest anchor hooks suitable for the connection and installation of personnel's fall arrest equipment. Spacing of anchor points to be guided by span between pipe joints and applicable OHS requirements.

Non-Reinforced Concrete Pipe

Non-reinforced concrete pipe shall conform to ASTM C14/C14M. All pipe shall be subject to such tests as outlined under ASTM Specifications and evidence shall be submitted to Water Resources.

For approved materials list see [402.01.01 Non-Reinforced Concrete Pipe](#).

Reinforced Concrete Pipe

Reinforced Concrete Pipe 900mm and smaller shall conform to ASTM C76/ C76M (Reinforced Concrete Culvert, Storm Drain, and Sewer Pipe) and shall be designed according to the 'Fill Height Table' as provided in the City's 'Design Guidelines For Subdivision Servicing' document. All pipes shall be subject to tests as outlined under ASTM Specifications and evidence shall be submitted to Water Resources.

Reinforced concrete pipe, sizes 1050 mm and larger may be designed by direct design methods in accordance with the American Society of Civil Engineers (ASCE) Standard Practice for Direct Design of Buried Precast Concrete Pipe using Standard Installations (SIDD) 15 and shall conform to ASTM C1417.

Reports shall be provided to the Engineer showing that the manufacturer of the concrete pipe has completed the reinforced concrete design by direct design methods in accordance with ASCE SIDD No. 15. The manufacturer will also provide written certification that the product meets the design carried out by the original design engineer responsible for the project.

For approved materials list see [402.01.01 Reinforced Concrete Pipe](#).

402.03.02 Reinforced Concrete Box Conduit (Duct)

Concrete box conduit shall be manufactured from sulphate resistant cement Type HS (Type 50) in accordance with CSA A3001 or Type V in accordance with ASTM C150.

Reinforced concrete box conduit shall conform to ASTM C1433 or ASTM C1433M. Physical properties testing shall be provided as specified in ASTM C1433 or ASTM C1433M and a certified copy of the test results shall be provided to Water Resources.

Coated supports and spacers shall be used as approved by the Engineer to minimize the potential for rust staining on the concrete surfaces on the inside of the box conduit.

Concrete box conduit shall be designed to resist all loads, including dead loads, earth loads including lateral pressures, internal and external hydrostatic loads, vehicle loads, and any other loads specified on the approved construction drawings. When requested by the Engineer, a copy of concrete box conduit designs stamped and signed by a Professional Engineer registered with APEGA shall be submitted.

Concrete box conduit joints must be sealed using a combination of accepted products or approved equal. See [402.04.04 Concrete Box Conduit Joints](#) for more details.

For approved materials list see [402.01.01 Reinforced Concrete Box Conduit \(Duct\)](#).

402.03.03 PVC Pipe

All PVC pipe shall be CSA approved. Materials used for pipe shall come from a single compound manufacturer and have a cell classification of 12454-B, 12454-C, or 12364-C as defined in ASTM D1784 (Rigid PVC Compounds and CPVC Compounds). All PVC pipe shall be designed for CL-800 truck loading as per CAN/CSA-S6-00 (Canadian Highway Bridge Design Code). Where warranted based on traffic volumes, sewer alignment, and the nature of the traffic route, the designer shall review the possible impact of dual or passing CL-800 trucks.

All PVC pipe shall meet the physical requirements given in CSA B182.1 M (Plastic Drain and Sewer Pipe and Pipe Fittings) and CSA B182.2 M (PVC Sewer Pipe and Fittings). All pipes shall be subject to such tests as required in the CSA standards and results for specific pipe data shall be submitted to Water Resources if requested.

PVC pipe shall be installed according to ASTM D2321 (Underground Installation of Flexible Thermoplastic Sewer Pipe).

For approved materials list see [402.01.01 PVC Pipe](#).

402.03.04 Corrugated Steel Pipe

All materials shall conform to the CSA G401 and shall be subject to such tests as outlined in that standard. ***Corrugated Steel Pipe (CSP) and Structural Plate Corrugated Steel Pipe (SPCSP) shall be manufactured by a fabricator certified to CSA G401 by an independent agency accredited by the Standards Council of Canada.***

Corrugated steel pipe shall only be used for storm sewer mains to which there are no direct connections from catch basins or house services (weeping tile drains), and only where specifically approved by Water Resources.

Pipe

Pipe shall have helical corrugated lock seams with the ends re-corrugated to provide annular corrugations for couplers. Riveted pipe is not accepted.

The dimensions of the corrugations shall be stipulated by the design engineer to suit the live and dead loads to which the pipe will be subjected to, giving consideration to the type of pipe embedment.

Pipe shall have the following minimum wall thickness:

Nominal Diameter	Minimum Wall Thickness*
<600 mm	2.0 mm
600 mm to 900 mm	2.8 mm
>900 mm	3.5 mm

*The wall thickness shall be stipulated by the design engineer based on depth of bury, soil conditions, pipe bedding and initial backfill, and other factors, but shall at no time be less than the minimum thickness as noted.

Pipe shall be coated with:

- 13) Zinc at 610 g/m², or
- 14) Aluminum at 305 g/m², or
- 15) Zinc at 610 g/m² together with a polymer coating

The selection of coating shall be based on the following table. More resistant pipe coatings may be used in place of less resistant pipe coatings (Aluminum can be used in place of 610 Zinc; Zinc with Polymer can be used in place of either 610 Zinc or Aluminum). Where soil or water conditions vary throughout the year, the most severe conditions shall govern the coating selection.

Type of Coating ^a	pH Level	Electrical Resistivity
Zinc (610 g/m ²)	6.0 to 8.0	> 2500 ohm-cm
Aluminum	5.0 to 9.0	1500 to 2500 ohm-cm
Zinc with Polymer ^b	< 5.0 and > 9.0 ^c	< 1500 ohm-cm ^b

^a. Additional coatings such as asphalt, with or without fibre reinforcing, shall be specified by the design engineer where site conditions warrant.

^b. Corrugated steel pipe is only permitted to be installed in these soil and ground water conditions with specific approval from Water Resources on a case-by-case basis.

^c. The amount of Zinc coating (minimum 610 g/m²), the type and thickness of Polymer coating, and any other required coatings must be submitted to Water Resources for approval prior to installation.

Couplers

- Couplers shall be corrugated to conform to the annular corrugations on the pipe ends on which they are being installed.
- Couplers shall have the same or better coatings as the pipe on which they are being installed.
- Couplers shall be of sufficient length so as to extend over a minimum of 2 complete corrugation crests and valleys on each pipe end, and shall be capable of providing a water tight joint when installed with gaskets in accordance with the manufacturer's recommendations.
- The coupler shall have a sufficient number of closure bolts such that when the coupler is drawn closed all parts of the coupler have uniform tension and there is no warping or distortion on any part of the coupler.
- Couplers must be supplied by the pipe manufacturer.

Gaskets

Gaskets shall be one-piece sleeve or wrap-around strip type, supplied by the pipe manufacturer, of sufficient thickness to fill the annular space between the pipe and coupler to provide an effective water tight joint.

402.03.05 Profile Pipe

For all profile pipe, cast-in manhole structure connectors shall be specifically designed for use with the type of profile pipe used. When a connector is required to let profile pipe into an existing structure via a cored or cut hole, the manhole connector shall be one of those listed in [402.01.05 Manhole Connections](#).

PVC

PVC profile pipe shall conform to the design loading requirement described in 402.03.03 PVC Pipe. Profile PVC storm pipe shall be CSA certified, shall conform to CSA B182.4 (Profile PVC Pipe and Fittings), and shall be subject to such tests as outlined under the standard. Materials used for pipe and fittings shall come from a single compound manufacturer and have a cell classification of 12454-B, 12454-C, or 12364-C as defined in ASTM D1784 (Rigid PVC Compounds and CPVC Compounds).

Profile PVC pipe shall conform to ASTM F794 (Standard Specification for Poly Vinyl Chloride (PVC) Profile Gravity Sewer Pipe and Fittings Based on Controlled Inside Diameter).

PVC Profile Pipe is to be used in storm system construction only.

Ultra-Rib and Raurib pipe require a maximum aggregate size of 20mm for pipe embedment of all sizes up to the maximum pipe size of 600mm. Embedment ***installation procedure*** requirements for ***Napco Royal*** Kor Flo, and Ultra-X2 pipe are the same as PVC DR 35, solid wall pipe.

For approved materials list see [402.01.01 PVC Profile Pipe](#).

Polypropylene Profile Pipe

Polypropylene profile pipe shall be designed for CL-800 truck loading as per CAN/CSA-S6 (Canadian Highway Bridge Design Code) and shall conform to CSA B182.13, subject to such tests as outlined under the standard. Materials used for pipe and fittings shall come from a single compound manufacturer.

Polypropylene profile pipe is to be used in storm sewer system construction only.

Polypropylene profile pipe requires a maximum aggregate size of 20 mm for pipe embedment of all sizes of dual-wall pipe up to the maximum pipe size of 750 mm. 1200 mm to 1500 mm pipe sizes are permitted only with approval on a case-by-case basis.

Manhole connection details required for all 1200mm to 1500mm polypropylene profile pipe.

Sani-Tite HP shall be Dual-wall for sizes 300 to 750 mm, and Triple-wall for sizes 750 to 1500mm.

For approved materials list see [402.01.01 Polypropylene Profile Pipe](#).

402.03.06 HDPE Pipe

HDPE Pipe products are not approved for use except for service leads using pipe bursting (see [403.05.06 HDPE Pipe Bursting Procedures for Replacing Sanitary Services](#)), and for sanitary sewer forcemain applications.

For service lead applications using pipe bursting, HDPE materials for pipe and fittings shall come from a single compound manufacturer and conform to ASTM D3350. Closed and open

profile pipe products and fittings shall conform to sections 4 and 5 of CSA B182.6 and CSA B182.8 for manufactured quality and dimensional tolerances. Resin compounds shall be tested for slow crack growth resistance as per Appendix SP-NCTL in ASTM D5397 as modified in Clause 8.8 of CSA B182.8.

For sanitary sewer forcemain applications, HDPE pipe and fittings shall conform to the AWWA C906-99 Standard and shall be PE 3408 with a dimension ratio (DR) 11 and working pressure rating (WPR) 160 psi, unless otherwise approved.

For sanitary sewer forcemain applications, please refer to section 503.02.05 of *Standard Specifications Waterworks Construction*. The following exception to the Waterworks Specification shall apply: HDPE pipe for sanitary sewer forcemain use must be identified by green longitudinal printing, striping, or a green outer-shell.

The outside diameter (OD) shall conform to ductile iron (DIPS) unless otherwise approved by the Engineer. HDPE project design shall conform to the design principles outlined by AWWA M55 Design Manual.

Operator certifications for each fusing method employed on a project shall be presented for inspection and shall have a date no more than one calendar year previous to be considered valid. All butt and electro-fusion shall be performed in the presence of the Engineer unless otherwise approved. Microprocessor fusing logs shall be submitted to the Engineer for every butt fuse made, and for each electro-fuse fitting where used. Butt fusing shall not commence on site until the Fusing Operator has successfully completed a "Bent Strap" test (as per the Plastics Pipe Institute Handbook) to the satisfaction of the Engineer.

402.03.07 FRP Pipe

For H2S Resistant Service or other Application where Approved.

CCFRPM (centrifugally cast)

FRP pipe for gravity or sewer syphon service where approved shall be Hobas Pipe or an approved equal. Pipe bedding shall be a Type 1 installation with Class 1 material as specified on Sheet 33B. Pipe stiffness shall be a minimum 320KPa (46 psi), and resin a minimum of type "VA". Where design conditions require stiffness in excess of this minimum, pipe thickness and pipe installation methods shall comply with the guidelines in AWWA M45 "Fiberglass Pipe Design Manual" and pipe resin or lining shall be as recommended by the Manufacturer for H2S service. Unless otherwise approved, the pipe shall be field connected with Hobas FWC (pressure rated) sleeve couplings or approved equal. Joint deflections shall be as specified by the Manufacturers Installation Guide. Joints must meet the performance requirements of ASTM D4161 and be suitable for pressure service to a minimum of 45 psi. Joints at closure tie-ins, where approved, may use all stainless steel or coated metallic closure couplings under cathodic protection as specified in the Standard Specifications Waterworks Construction.

RTRP (Filament wound)

FRP pipe for gravity sewer or sewer syphon service shall be Flowtite Pipe or approved equal. Pipe bedding shall be a Type 1 installation with Class 1 material as specified on Sheet 33B. Pipe stiffness shall be a minimum 320KPa (46psi). Where design conditions require stiffness in excess of this minimum, pipe thickness, pipe

bedding design and pipe installation methods shall comply with the guidelines in AWWA M45 "Fiberglass Pipe Design Manual" and resin or lining type shall be as recommended by the Manufacturer for H2S service. Unless otherwise approved, the pipe shall be field connected with Flowtite GRP (pressure rated) sleeve couplings. Joint deflections shall be as specified by the Manufacturers Installation Guide. Joints must meet the performance requirements of ASTM D4161 and be suitable for pressure service to a minimum of 45 psi. Joints at closure tie-ins, where approved, may consist of all stainless steel or well coated (coating rated for H2S) metallic closure couplings under cathodic protection as specified in the Standard Specifications Waterworks Construction.

Appurtenances and MH Connections

Flanges, elbows, reducers, tees, wyes, laterals and other fittings shall be Hobas or Flowtite supplied and capable of withstanding all operating conditions when installed. They may be either contact molded or manufactured from mitered sections of pipe joined by glass-fiber-reinforced overlays. Pipe connection to manholes shall be made by cast in gasket, cast in wall manufacturer supplied connector (Hobas FWC or Flowtite respectively) or with approved expandable boot seal connector in cored hole.

402.04.00 SEWER PIPE JOINTS, FITTINGS AND CASING SPACERS

402.04.01 Gaskets

PVC Pipe

Gaskets shall be supplied by the manufacturer. All gaskets shall conform to ASTM F477 (Elastomeric Seals (Gaskets) for Joining Plastic Pipes) and shall be subject to such tests as outlined under the ASTM Specifications.

Concrete Pipe

All gaskets shall conform to CSA A257.3 (Joints for Circular Concrete Sewer and Culvert Pipe, Manhole Sections, and Fittings Using Rubber Gaskets) or ASTM C443 (Joints for Circular Concrete Sewer and Culvert Pipe (Using Rubber Gaskets)), and shall be subject to such tests as outlined under the Specifications.

402.04.02 Mortar

Mortar, if specifically required and approved for pipe joints, shall consist of one part sulphate resistant cement Type HS (Type 50) in accordance with CSA A3001 or Type V in accordance with ASTM C150 to two parts of clear sharp sand.

402.04.03 Sewer Pipe Plug

For diversion or isolation of flow, use a commercially available inflatable plug suitable for required pressure so that all or a portion of flow can be released.

Whenever work is stopped for the day or suspended temporarily, install a removable watertight bulkhead at open end to prevent entry of debris and other foreign materials. Bulkhead must be secured against flotation or movement.

For abandonment of pipe, see [Abandonment of Sewer Pipe - General](#).

402.04.04 Concrete Box Conduit Joints

Unless otherwise specified on the approved drawings or contract specifications, joints must be sealed according to the different treatment options indicated in [Drawing 65: Precast Concrete Box Joint Treatment Guideline and Service Connectors](#)

Maximum allowable joint width is 20mm.

All joints must be thoroughly cleaned and free from any debris and moisture before sealant is applied. Follow installation procedures as recommended by sealant manufacturer including primer application when needed.

To ensure optimal bonding conditions, install joint sealant a minimum of 28 days after the date of fabrication stamped on the concrete duct and, in all cases, within 28 days of duct installation.

402.04.05 Fabricated and Injection Molded Fittings and Couplings for PVC Sewer Pipe

All fittings shall have a CSA sticker and be approved under CSA B182.2 (PVC Sewer Pipe and Fittings PSM Type) or CSA B182.4 (Profile PVC Sewer Pipe and Fittings). Materials used for molded fittings shall come from a single compound manufacturer and have a cell classification of 12364-C, 12454-B, 12454-C, or 13343-C as defined in ASTM D1784 (Rigid PVC Compounds and CPVC Compounds).

Locations proposed for Fabricated Fittings must be shown on the Construction Drawings and approved by the Engineer.

All couplings must be CSA approved and conform to ASTM C1173-06, D5926-04 and shall be subject to such tests as outlined under the ASTM specifications.

402.04.06 Casing Spacers for Carrier and Encasement Pipe

Skid height shall be such that there is a maximum space of 25 mm between the skid and casing pipe. If space is greater than 25 mm the void must be filled with sand or grout.

Encasement Pipe

See [403.05.09 Encasement Pipe](#) for specifications and sizing information.

Carrier Pipe

See [403.05.09 Carrier Pipe](#) for information.

402.05.00 SERVICES

402.05.01 Service Leads

All pipe materials shall conform to the material specifications set forward within [402.03.00 Sewer Pipe](#).

The pipe diameter for service leads shall be limited to the sizes for the type of pipe shown in [402.01.04 Service Lead Pipes](#).

For polyethylene pipe bursting requirements for service line replacements, refer to the pipe

bursting procedures for replacing sanitary services detailed in [403.05.06 HDPE Pipe Bursting Procedures for Replacing Sanitary Services](#).

402.05.02 Service Lead Jointing Material

All service lead joints shall be made watertight and root proof with jointing materials supplied by the manufacturer. All jointing materials shall be approved by the Engineer prior to use.

For approved materials see [402.01.04 Service Lead Jointing Material](#)

402.05.03 Service Lead Bends, Adaptors, Fittings and Connectors

All bends, adaptors and fittings shall be supplied by the service lead manufacturer and approved by the Engineer.

Bends consisting of a 22.5° deflection shall be used when required as per the Canadian Plumbing Code.

All service lead bends, adapters and fittings shall conform to the material specifications set forward within [402.04.00 Sewer Pipe Joints, Fittings and Casing Spacers](#).

All service connectors shall conform to the material specifications set forward within [402.03.03 PVC Pipe](#).

402.05.04 Connector Sealants

All sealants used for bonding service saddles to sewer mains shall be approved by the Engineer. For approved materials see [Approved Products: 402.01.04 Connector Sealants](#).

402.06.00 MANHOLES

402.06.01 Manholes - General

All concrete used in the construction of manholes shall be manufactured from sulphate resistant cement Type HS (Type 50) in accordance with CSA A3001 or Type V in accordance with ASTM C150. All concrete structures shall be designed for CL-800 truck loading as per CSA-S6-00 (Canadian Highway Bridge Design Code). All precast reinforced concrete manhole sections shall conform to ASTM C478.

Concrete compressive strength shall be **35 MPa** at 28 days and air content shall be 4-7% except where no slump concrete is used. Concrete cover shall be a minimum of 25 mm.

All precast reinforced concrete manhole barrels, bases, slab tops, adapters and risers shall conform to ASTM C478 (Precast Reinforced Concrete Manhole Sections) and CSA 257.4 (Precast Reinforced Circular Concrete Manhole Sections, Catch Basins and Fittings). All pre-cast sanitary manhole bases shall be constructed with rubber gaskets or an approved equivalent sealant material. Benching concrete compressive strength shall be **35 MPa** at 28 days according to [Drawing 39: Benching Standards for Sewer Manholes](#) of these specifications.

Reinforcing steel shall conform to CSA G30.18M (Billet Steel Bars for Concrete Reinforcement) and shall be intermediate grade with yield strength of deformed bars equal to 400 MPa.

Welded wire reinforcement shall conform to ASTM A1064/1064M (Carbon-Steel Wire and

Welded Wire Reinforcement, Plain and Deformed for Concrete) and shall have yield strength of 450Mpa for Plain and 480Mpa for Deformed Welded Wire Mesh.

For Type 5A Interior Drop Manhole, PVC Pipe shall be DR 35 in accordance with CSA B182.2 (PVC Sewer Pipe and Fittings (PSM Type)).

For round manholes with large diameter flexible pipe connections (1200 to 1500 mm sizes) where an approved cast-in gasket or boot type connector is not supplied by the manhole manufacturer, a detail drawing stamped and signed by a Professional Engineer is required indicating that the following items have been considered on their design:

- a) Structural impact of size of hole when large PVC pipe is installed
- b) Sealing device used to ensure watertight connection **meeting ASTM C923**
- c) Pipe protrusions at invert and obvert on the inside manhole wall must be minimized to prevent debris from accumulating in the pockets of the protruded pipe edges. A 900mm minimum clear space between protrusions is required for maintenance purposes.

Deep Manholes

Sanitary manholes exceeding 8.0 meters in depth from finished rim elevation to lowest invert shall be constructed as follows:

- a) 5A manholes shall be at a minimum of 1500 mm inside diameter barrels with base and slab top to match as shown on drawing 18A, except that the frame and cover shall be 900mm **or as shown in Sheet 1B.**
- b) Type 1 ([drawing #17](#)) and 1-S ([drawing #18](#)) manholes shall be at a minimum of 1500 mm x 1500 mm inside dimensions, and shall have 1500 mm inside diameter barrels with slab top to match as shown in [drawing 18A](#), except that the frame and cover shall be 900mm **or as shown in Sheet 1B.**

All materials under this section shall be constructed according to the dimensions and material specifications shown in [404.00.00 Detailed Drawings.](#)

For approved materials see [402.01.05 Manholes.](#)

For manhole cover casting specifications see [402.12.02 Manhole.](#)

402.06.02 Manhole Barrel Jointing Material

All gaskets shall conform to CSA A257.3 (Joints for Circular Concrete Sewer and Culvert Pipe, Manhole Sections, and Fittings Using Rubber Gaskets) or ASTM C443 (Joints for Circular Concrete Sewer and Culvert Pipe (Using Rubber Gaskets)), or **ASTM C1619 Class E (Elastomeric Seals for Joining Concrete Structures).** All gaskets shall be subject to such tests as outlined under the Specifications.

Material supplied or recommended by the manufacturer and approved by the Engineer shall be used in each barrel joint.

Where manhole section/riser joints are located below the ground water table they shall be externally sealed with an encapsulating water infiltration prevention wrap system. Approved systems are CCI WrapidSeal, PSI Riser Wrap, **Press Seal EZ-Wrap** and ConSeal CS 212.

If pipe penetration occurs right at a joint between two manhole barrels, use mortar as described in [402.06.04 Mortar.](#) Mortar shall be placed on the exterior of the barrel joint.

402.06.03 Manhole Steps

Aluminum and polypropylene coated aluminum manhole steps shall conform to CSA CAN3-S157 (Strength Design in Aluminum).

Steel manhole steps shall conform to ASTM A36 (Carbon Structural Steel) and shall have a yield strength of 240 MPa. The steps shall be hot dip galvanized according to ASTM A123 (Zinc (Hot-Dipped Galvanized) Coatings on Iron and Steel Products).

Steel reinforced polypropylene manhole steps shall conform to ASTM C478 and C497. Polypropylene shall conform to ASTM D4101-82 and steel rod shall be Grade 60 conforming to ASTM A-615 requirements.

All steps within a manhole shall be of the same manufacturer and design, type and size. Mixing of unmatched steps within the same manhole is unacceptable. Align steps vertically. Loose steps shall be cause of rejection of that barrel section. Any field repair or replacement of steps shall be to the satisfaction of the Water Resources Inspector.

The grade of the base material, and the shape and size of the steps shall be as shown on [Drawing 9: Manhole Steps](#).

For approved materials see [Manhole Steps](#).

402.06.04 Mortar

Mortar used for sealing pipe penetrations and for setting collars/adjustment rings/frames on manholes and catch basins shall be a Type ‘M’ mortar suitable for below grade, load bearing work as per ASTM C270, consisting of 3 parts Portland cement to 1 part Hydrated lime and 12 parts sharp sand. Cement shall be sulphate resistant Portland cement Type HS (formerly Type 50) in accordance with CSA A3001 or Type V as per ASTM C150. Pre-packaged commercially available Type ‘M’ masonry mixes are acceptable.

Where an accelerated set of pipe penetration mortaring is required to address weather or work schedule time constraints prior to commencement of backfill, a rapid setting high strength non-shrink packaged mortar mix may be employed as per the manufacturer’s specifications. Use CTS Rapid Set Mortar Mix designed to achieve 4000 psi (25 mPa) in 3 hours at minimum 7 degrees C, or approved equal. Hoard and heat mortar application area as required. Backfill may commence 4 hours after mortar application is complete.

402.07.00 CATCH BASINS

402.07.01 Catch Basins - General

All catch basin slab tops, collars, barrels, and bases shall conform to ASTM C478 (Precast Reinforced Concrete Manhole Sections) and CSA A257.4 (Precast Reinforced Circular Concrete Manhole Sections, Catch Basins and Fittings). All concrete used in the construction of catch basins shall be manufactured from sulphate-resistant cement Type HS (Type 50) in accordance with CSA A3001 or Type V in accordance with ASTM C150.

Concrete compressive strength shall be **35 MPa** at 28 days and air content shall be 4 – 7% except where no slump concrete is used. Concrete cover shall be 30 mm minimum.

Reinforcing steel shall conform to CSA G30.18M (Billet Steel Bars for Concrete Reinforcement) and shall be intermediate grade with yield strength of deformed bars equal to 400MPa.

All concrete structures shall be designed for CL-800 truck loading as per CSA-S6-00 (Canadian Highway Bridge Design Code).

For approved materials list see [402.01.06 Catch Basins](#).

For catch basin casting specifications see [402.12.03 Catch Basin](#).

402.07.02 Sump Catch Basins

Sump catch basins shall be installed on a case-by-case basis where approved and shall conform to the design as shown on drawings 43A-2 and 43B-2 (ICD detail). A detailed drawing of the catch basin installation including the dimensions of the sump shall be included with the construction drawings submitted for approval.

402.08.00 STANDARD DRAINAGE SWALE

All standard drainage swales shall be constructed according to the dimensions and material specifications shown on the following drawings:

- [Drawing 32: Standard Drainage Swale Easement Crossing](#)
- Drawing 32A: Deleted - refer to Standard Specifications: Road Construction, Sheet #46
- Drawing 32B: Deleted - refer to Standard Specifications: Road Construction, Sheet #48
- [Drawing 32C: Swale Detail High-Back and Overland Escape Route](#)

Base preparation, installation, finishing and testing shall conform to sections 302, 303, 310 and 311 of the *Standard Specifications: Road Construction*.

Concrete Finishing shall conform to the specifications outlined in [403.11.10 Concrete Finishes](#).

402.09.00 CAST-IN-PLACE CONCRETE

402.09.01 Concrete Formwork

Design by the Contractor

The Contractor shall design formwork and shoring to safely support all vertical and lateral loads, so that all concrete members will be of the correct dimension, shape, alignment, elevation, and position, and have the specified finish.

In general, formwork and shoring shall be designed in accordance with the applicable requirements of CSA S269.1, CSA 269.3, ACI 347, CSA O86, and CAN/CSA S16.

All concrete structures shall be designed for CL-800 truck loading as per CSA-S6-00 (Canadian Highway Bridge Design Code).

All applicable codes and regulations shall be complied with, respecting safety in the design and construction of formwork and shoring. Where required by regulatory requirements, formwork and shoring designs shall be stamped by a Professional Engineer registered with APEGA.

Materials

Forms shall be either wood or steel unless specified otherwise.

For all permanently exposed concrete surfaces (i.e. concrete surfaces that will not be covered by backfill or concrete), high-density overlaid plywood forms or steel panels made of clean, smooth material, free from holes, surface markings and defects shall be used. Use similar forming material for each element to produce similar surface textures, colour and appearance.

False work materials shall conform to CSA S269.1, Table 1. Materials bearing grade marks or accompanied with certificates, test reports or other proof of conformity shall be provided.

Removable or snap-off metal form ties shall be provided which are fixed or adjustable in length, free of devices leaving holes larger than 25 mm diameter in concrete and that break off no closer than 25 mm to the concrete surface.

Provide a release agent that will not stain the concrete. Release agents to be approved by the Engineer.

An approved sealer or form liner to prevent absorption of moisture from the concrete shall be used.

402.09.02 Concrete Reinforcement

Shop drawings shall be submitted for concrete reinforcement prior to fabrication.

Certified mill test reports shall be submitted for concrete reinforcement when requested by the Engineer.

Cold bend bars strictly as per approved shop drawings. Bars shall be furnished in lengths indicated.

Reinforcing Bars

Reinforcing bars shall be billet-steel deformed bars conforming to CSA G.30.18, Grade 400.

Epoxy Coated Reinforcing Bars

Epoxy-coated reinforcing bars shall conform to ASTM A775/A775M and CSA G30.18, Grade 400.

Steel Wire Fabric

Steel welded wire reinforcement shall be in accordance with ASTM A1064.

Deformed steel welded wire reinforcement shall be in accordance with ASTM A497/A497M.

Wire Ties

Plain, cold drawn annealed steel wire conforming to CSA G30.3 shall be used.

Accessories

Bar supports, bolsters, chairs and spacers shall conform to ACI 315 - "Manual of Standard Practice for Detailing Reinforced Concrete Structures". Chairs made of non-ferrous metal or other approved non-staining material in slabs where the underside will be exposed to view shall be used.

402.09.03 Structural Concrete

General

Concrete shall be furnished which shall develop a compressive strength no less than that shown on the construction plans or in [404.00.00 Detailed Drawings](#).

Aggregate

All sources of aggregate used shall meet the requirements of these specifications. Lightweight aggregate shall meet requirements of ASTM C33 for lightweight aggregate for structural concrete.

Fine Aggregate

Fine aggregate shall meet the requirements of ASTM C33 except as modified by the following paragraphs:

Fine aggregate shall be natural sand, washed clean, having hard, strong, sharp, durable, uncoated grains and shall be free from injurious amounts of dust, lumps, soft or flaky particles, mica, shale, alkali, organic matter, loam, or other deleterious substances.

If frequent rejections occur, no further sand will be accepted from that source and another approved source will be required.

Coarse Aggregate

Coarse aggregate shall conform to the requirements of ASTM C33 except as modified by the following paragraphs:

Coarse aggregate shall consist of gravel or broken stone composed of strong, hard, durable, uncoated pebbles, or rock fragments washed clean and free from injurious amounts of shale, coal, clay, lumps, soft fragments, dirt, glass and organic or other deleterious substances.

Aggregate sizing shall conform to ASTM C33 as indicated below. Aggregates shall be kept clean and free from all other materials during transportation and handling. The aggregates shall be kept separated from each other at the site, until measured and placed in the mixer.

PERCENT PASSING BY WEIGHT			
Sieve Size (mm)	Nominal 40 mm	Nominal 25 mm	Nominal 20 mm
50	100		
40	95-100	100	
25		95-100	100
20	35-70		90-100
13		25-60	
10	10-30		20-55
No. 4	0-5	0-10	0-10
No. 8		0-5	0-5

Cement, Water and Additives

Portland Cement

Cement used on the work shall be Portland Cement. Bulk or bag cement may be used, but bulk cement shall be batched by an approved weighing device. The cement shall be sulphate resistant and meet the requirements of ASTM C150 (Type V) or CSA A3001 (Type HS (50)).

Cement Content

A minimum amount of cement shall be used to produce the required strength of concrete as shown on the construction plans or in [404.00.00 Detailed Drawings](#).

Water Reducing Agent

Water reducing admixtures shall conform to Type "A" ASTM C494.

Water

Water used in mixing concrete shall be clean and shall not contain deleterious amounts of acids, alkalis or organic materials. All water shall be furnished from approved sources.

Air Entrainment Agent

Air Entrainment Agent Material shall be added to all slump concrete mix for entraining from 4% to 7%, with an average of 5% of the air in the concrete by volume. Air Entraining Admixtures for concrete shall conform to ASTM C260.

402.09.04 Testing Requirements

General

The testing of random batches shall be done and test data shall be furnished to the Engineer. Reports shall include the following:

- 16) Job to which concrete is being supplied
- 17) Date of sampling
- 18) Air temperature when sampling
- 19) Temperature of mix
- 20) Name of supplier
- 21) Exact location on the structure in which the concrete is being placed
- 22) Specimen number
- 23) Slump
- 24) Age of test
- 25) Cylinder test
- 26) Method of curing
- 27) Air content
- 28) Type of cement
- 29) Time batched and unloaded

Slump shall be determined in accordance with ASTM C143.

Air content shall be determined in accordance with ASTM C231.

When making tests on fresh concrete, not less than three specimens for each test shall be molded for compressive tests to ASTM C192/C192M and ASTM C39. One cylinder shall be tested at seven days and two at 28 days.

The following shall be the minimum acceptable standard for the number of concrete tests required for the combination of storm and sanitary utilities:

SEWER	One test for each 50 cubic meters of concrete, or fraction DUCT thereof, and in any event, not less than one test for each class of concrete used during each day.
MANHOLES	One test for every 10 manholes poured in a batch (a batch can include both storm and sanitary) and, in any event, not less than one test for the number of manholes between 1 and 10.
BULK CONCRETE	One test for every 50 cubic meters of concrete used or one test each inlet/outlet, junction, control and miscellaneous structure and every 10 manholes in a batch (including both storm and sanitary) and catch basins where bulk concrete is used for base slabs and/or benching, whichever is greater, but not less than one test per batch.
CONCRETE DRAINAGE SWALES	One test for every 300 lineal m but not less than one test for a daily pour.

When the temperature is below 0° C during a pour or is likely to fall below 0° C within 24 hours after a pour is made, two additional specimens for each test shall be made. These two cylinders will be field cured on the job in a manner which simulates as closely as possible the curing of the volume of concrete sampled and tested at 28 days.

In the event that testing indicates substandard materials and workmanship, further testing shall be completed.

Test Cylinders

Test cylinders shall be made and stored in accordance with ASTM C31 and will be tested in accordance with ASTM C39. In hot weather, correct storage temperatures may be maintained by ventilation from sand or burlap, and in cold weather by using heating devices.

When heating is impractical at the site it should be noted that cylinders are not to be transported any considerable distance immediately after molding. It is preferable to transport the sample of concrete to the molding and curing site, so that the freshly molded specimens will be moved only a few feet by hand. The cylinders should always be handled in a manner which provides the test results with adequate protection against damage and ensures that the test results will provide a sound basis for evaluation of concrete quality.

Strength Requirements

To conform to the strength requirements the average of all tests shall exceed the specified strength. When five or more tests of the same class of concrete are available, the average of any five consecutive tests shall be equal to, or greater than the specified strength. No three consecutive tests shall fall below the specified strength, and no strength test shall fall below 3.5 MPa of the specified strength. Where these criteria are not met, the Engineer shall have the right to require one or more of the following:

- 30) Changes in mix proportions for the remainder of the work.
- 31) The additional curing on those portions of the structure represented by the test specimen which failed.
- 32) That cores be drilled from the portion of the structure in question and tested in accordance with CSA A23.2. The result of this test will help ascertain whether or not the specimens previously tested were truly representative of the concrete in place.

If, after carrying out the requirements mentioned above, the Engineer is not satisfied that the concrete in the structure is of the specified quality, he/she may demand a strengthening or replacement of those portions which failed to develop the required strength.

402.09.05 Mix Design

All concrete shall be proportioned according to mix designs prepared by a Professional Engineer employed by an independent engineering material testing laboratory for the classes of concrete and nominal maximum size of coarse aggregate specified except where the concrete is to be supplied by a ready-mix plant. Where the Engineer so permits, mix designs may be prepared by a Professional Engineer employed by the plant.

Concrete shall be designed to produce minimum cement content for each class of concrete shown on the construction plans. The concrete mix shall be so designed that the material will not segregate, and excessive bleeding will not occur. A copy of the mix design shall be made available to the Engineer upon request.

High early strength mixes designed for rapid setting requirements shall be delivered with documentation stating the design compressive strength achieved at 12 hours and 24 hours after placement.

402.10.00 EMBEDMENT MATERIAL

402.10.01 Bedding Material

Bedding shall be of the type and class specified within the approved construction drawings, and if not so specified in the construction drawings, shall conform to the details shown in [Drawing 33: Bedding and Backfill Details for Rigid Pipe](#) and [Drawing 33B: Bedding and Backfill Details for Flexible Pipe](#) and the following requirements:

- Bedding material shall consist of hard durable particles free from clay lumps, cementation, organic material, frozen material and other deleterious materials.
- Bedding material shall conform to the embedment materials specified in ASTM D2321.

The following tables must be used in conjunction with Drawings 33 and 33B. The bedding materials listed are divided into Class 1A, 1B, II, and III consistent with ASTM D2321 (Flexible Pipe Installation Specification) and ASCE Standard Practice for Concrete Pipe Design (SIDDD) 15.

Minus 20 mm bedding material is specified for pipe sizes 375 mm and smaller for improved support underneath the haunches of the pipe.

Class IA - Manufactured Aggregate; open graded, clean

For Pipe 375mm and Smaller	
Sieve Size	% Passing by Mass
20 mm	100%
4.75 mm (#4)	<10%
2.5 mm (#8)	<5%
0.075 mm (#200)	<5%

For Pipe Larger than 375 mm	
Sieve Size	% Passing by Mass
40 mm	100%
4.75 mm (#4)	<10%
2.5 mm (#8)	<5%
0.075 mm (#200)	<5%

Class IB - Manufactured, Processed Aggregate; dense graded, clean

For Pipe 375mm and Smaller	
Sieve Size	% Passing by Mass
20 mm	100%
4.75 mm (#4)	10% - 50%
2.5 mm (#8)	<5%
0.075 mm (#200)	<5%

For Pipe Larger than 375 mm	
Sieve Size	% Passing by Mass
40 mm	100%
4.75 mm (#4)	10% - 50%
2.5 mm (#8)	<5%
0.075 mm (#200)	<5%

Class II - Coarse-Grained Soils; clean or borderline clean to w/ fines

For Pipe 375mm and Smaller	
Sieve Size	% Passing by Mass
20 mm	100%
4.75 mm (#4)	Varies
0.075 mm (#200)	0% - 12%

For Pipe Larger than 375 mm	
Sieve Size	% Passing by Mass
40 mm	100%
4.75 mm (#4)	Varies
0.075 mm (#200)	0% - 12%

Class III – Coarse-Grained soils with fines

For Pipe 375mm and Smaller	
Sieve Size	% Passing by Mass
20 mm	100%
4.75 mm (#4)	Varies
0.075 mm (#200)	12% - 50%

For Pipe Larger than 375 mm	
Sieve Size	% Passing by Mass
40 mm	100%
4.75 mm (#4)	Varies
0.075 mm (#200)	12% - 50%

402.10.02 Concrete Encasement

Concrete shall be minimum 13.6 MPa strength and shall be manufactured from sulphate resistant cement Type HS (Type 50) in accordance with CSA A3001 or Type V in accordance with ASTM C150. No air entrainment is required for encasement concrete with more than 2.0 m of earth cover. Where groundwater flow is anticipated, material or products shall be used to mitigate the migration of fines into bedding material.

402.10.03 Warning Tape

Warning tape is to be a minimum of 150 mm wide, 0.125 mm thick, with a detectable metal foil layer and shall be fabricated with materials that are suitable for underground service (polyester/polyethylene). Sanitary and storm warning tape graphics are to include wording equivalent to “CAUTION SEWER LINE BURIED BELOW” on a green background as per the APWA colour codes.

402.11.00 FOUNDATION STABILIZATION MATERIAL

Stabilizing foundation gravel shall consist of hard durable particles, free from clay lumps, cementation, organic material, frozen material and other deleterious materials.

The material shall be a Class 1A material as described above and in ASTM D2321 with a maximum aggregate size of 40 mm. Subject to Water Resources approval, pit run gravel may be used on a project instead of Class 1A material, provided a written request from a Specialist Geotechnical Engineer is received certifying the pit run material and there are less than 12% fines by mass passing the 0.075 mm (#200) sieve size.

Stabilizing foundation synthetic filter fabric shall consist of a durable, permeable, non-woven, polyester fabric composed of continuous synthetic filaments in a random arrangement with minimum properties as follows:

Fabric Weight	213 g/m ²
Thickness	2.0 mm
Tensile Grab Strength	710 N
Tear Strength	310 N
Mullen Burst Strength	2,000 kPa

402.12.00 CASTINGS

402.12.01 General

This applies to all grades of cast iron castings used for manhole frames, manhole covers, catch basin frames, grates and other applicable cast components.

Requirements for manufacturing, testing and inspection shall conform to AASHTO M306-10 except that any reference to ‘United States’ shall mean ‘Canada’ for this purpose. The required proof-load test as referred in AASHTO M306 shall be 178kN. Test results for each batch of casting shall be made available to Water Resources upon request.

Castings must bear a production code number to identify the material designation and batch information that can be used to track the product to its test bar data and metallurgical composition records. ASTM designation, name of producing foundry and country of manufacture preceded by the words “Made in,” such as “Made in USA” must appear also. The markings must be placed on a non-wear location.

Supplier shall submit annually by March 15 of the current year, a Certificate of Compliance authenticated by a QA/QC Engineer registered in the Province of Alberta stating that castings are produced in facilities operating in conformance to ISO 9001:2015. Certification

must indicate the casting's country of origin. The letter shall also state that all samples representing each batch have been tested and inspected in compliance to AASHTO M306-10.

All castings shall be true in form and dimensions, free from faults, sponginess, cracks, blow holes, and other defects. All horizontal bearing surfaces on round frames and covers or grates must be machined to ensure that they do not rock. Bearing surfaces between square and rectangular cast frames, covers and grates shall be matched to prevent rocking. All cast iron components shall be uncoated except when specifically required by the Engineer.

402.12.02 Manhole

Standard Manhole Cover: Gray cast iron shall conform to ASTM A48 (Gray Iron Castings) Class 35B.

Grated Manhole Cover: Ductile iron shall conform to ASTM A536 (Ductile Iron Castings) Grade 80-55-06.

90 mm Shallow Manhole Frame and Manhole Frame Riser: Ductile iron shall conform to ASTM A536 (Ductile Iron Castings) Grade 80-55-06.

402.12.03 Catch Basin

Catch Basin Grate and Side Inlet: Ductile iron shall conform to and be tested as outlined in ASTM A536 (Ductile Iron Castings) Grade 80-55-06.

Type 'C' Catch Basin Frame: Gray cast iron shall conform to ASTM A48 (Gray Iron Castings) Class 35B.

Type 'K-2' Catch Basin Frame: Gray cast iron shall conform to and be tested as outlined in ASTM A48 (Gray Iron Castings) Class 35B.

403.00.00 INSTALLATION

403.01.00 METHOD OF OBTAINING GRADE

403.01.01 General

The elevation of all sewers, structures or related appurtenances shall be determined by means of survey stakes established by a qualified surveyor. Once established, all work shall conform to the line and levels indicated on the surveyor's grade sheets.

The surveyor shall establish a line of stakes offset from the sewer location a sufficient distance to allow construction to pass without disturbing the stake line. Stakes shall be set 15 meters apart for all sewer mains and one stake shall be set for each manhole. All other sewer related structures shall be set with at least one stake.

The grade sheet shall contain the following information:

- The cuts from the invert to the top of the reference point
- The cuts from the invert to ground surface centre line
- Invert elevations of all sewer mains at each manhole
- Sewer main size, pipe material and class of pipe
- Bedding required
- Slope of sewer main
- Length of main

At all installations, when requested by the Engineer, an acceptable means of checking the grade and line of the sewer main, manhole or related structure shall be made available. The method of checking line and grade shall be as follows:

403.01.02 Line

The sewer main is to be set true by plumbing down from a taut cord stretching across the excavation perpendicular to the survey stake line.

403.01.03 Grade

All installations shall be set to grade by means of a measurement rod and four sight rails set at equal height from the grade line. The sewer main or structure shall be adjusted until the four sight rails and the tip of the rod, when the rod is held to the invert of the main or structure, are exactly in line. Construction shall not proceed until all sight rails line through correctly.

All other methods of checking shall be approved by the Engineer prior to implementation. The use of a laser is an acceptable alternate method of setting grade. A surveyed grade check(s) may be required.

403.02.00 EXCAVATION

403.02.01 General

All excavation shall be in accordance with the provisions of the Province of Alberta's *Occupational Health and Safety Act, Regulation and Code*.

Prior to any excavation proceeding within the vicinity of any Alberta Control Monuments, precautions shall be taken to protect all monuments from being disturbed. Methods of protection and contacts are specified on [Drawing 54: Alberta Survey Control Monument Protection Standard](#), [Drawing 55: Legal Survey Control Typical Sidewalk Manhole Installation](#), and [Drawing 56: Legal Survey Control Typical Roadway Manhole Installation](#).

An excavation permit must be obtained before beginning any excavation on public right of ways. Excavation permits are to be obtained from The City of Calgary Roads Maintenance, Main Floor, Building E, Manchester Centre, 2808 Spiller Road S.E. (403-268-4936). A copy of the excavation permit shall be posted at the work site in clear view for the Engineer.

Caution shall be exercised when excavating existing residential sanitary and storm services and/or mains as water services and water mains are usually located in close proximity to sanitary and storm servicing. This proximity presents a serious risk of cross contamination in circumstances where both the potable water system and the sanitary sewer system are intentionally or inadvertently opened simultaneously, such as during new installation, repair works and particularly where a water service or water main is damaged during a sewer works excavation. Should this occur, the Engineer must be notified immediately. On-site efforts to prevent potential cross contamination shall commence and be continued to ensure that no sewer effluent enters the water system. The Contractor shall comply with all direction provided by the Engineer to ensure the potable water system is protected from cross connection.

Where an open excavation exists due to on-going construction, any open sewer pipe shall be kept sealed at all times except at time of actual connection. Once the required connection(s) is made, the sewer pipe or service as well as any proximate water services and mains shall be sufficiently protected to prevent damage from debris falling from the banks of any excavation left open.

The depth of excavation shall be the depth required to install the sewer, manhole or related structure with the specified bedding as shown on the approved construction drawings or as indicated by the Engineer.

The width of the trench shall be constructed wide enough to permit proper placement of the material in the embedment zone.

Excavation shall be taken to mean the removal of all material from the trench.

The excavation material shall be neatly deposited at the sides of the trench in a manner as not to cause instability of the excavation slopes or obstruct streets, lanes, or access roads. A clear space shall be left on one side of the trench to accommodate the survey stakes. Where there is no available space to deposit the material on the side of the trench the material shall be stored elsewhere.

The excavation shall not advance more than 30 m ahead of the pipe or duct installation.

In no case unless approved by the Engineer shall water be allowed to enter the excavation during construction. All water pumped or drained from the work shall be disposed of in a suitable manner satisfactory to the Engineer, without damage to the construction work, other property, structures or persons.

A Drainage Permit is required from Water Resources, Development Delivery via email at (waterutilityinspections@calgary.ca), before any water from subdivisions under development may be disposed of through City sewer systems. For all other private sites and The City of Calgary contracts, contact the Water Resources Erosion Control Coordinator at (403-268-2655).

403.02.02 Rock Excavation

Rock excavation shall be divided into two categories, TYPE A and TYPE B, contingent upon its hardness and difficulty experienced in excavation.

It shall be the contractor's responsibility to demonstrate to the Engineer's satisfaction that the material cannot be removed with reasonable effort by conventional means. The Contractor may be required by the Engineer to seek out and explore planes of weakness or layering which may ease the excavation process.

Type A

Rock such as fractured sandstone, shale or ledge rock, silt stone, mudstone or other rock which can be removed with a backhoe rated by the Alberta Road Builders Association as a Group 17 Hydraulic Excavator. Alternately, the aforementioned rock or other rock which can be removed with a Group 10 Crawler Tractor with a single ripping tooth for open excavation or other equipment specified elsewhere in the documents and in the opinion of the Engineer, results in a substantial delay or decrease in the normal rate of excavation for the project and/or significant damage or wear to the excavating equipment.

Type B

Rock which requires drilling, blasting, wedging or jack-hammering to remove, as determined by the Engineer.

403.02.03 Explosives and Blasting

A letter requesting approval from the Engineer shall be submitted along with copies of all necessary permits and approval letters from approving agencies.

When explosives are used, their handling, storage and transportation shall be in accordance with City Bylaws, the provisions of the Explosives Act (Canada), and the regulations made thereunder, and with the provisions of the Province of Alberta's *Occupational Health and Safety Act, Regulation and Code*, or substitution therefore and with the applicable provisions respecting explosives and the transportation thereof found in the Calgary Fire Prevention Bylaw and the amendments thereto or substitutions therefore. In the event of any conflict or duplication of the provisions of the *Occupational Health and Safety Act, Regulation and Code* and the aforesaid bylaw, the more stringent provisions shall be complied with.

Blasting shall be carried out in accordance with all municipal, provincial and federal regulations. No blasting shall be carried out within 150 m of any water storage reservoir, water storage tank, or pumping station without the prior written approval of the Engineer. No blasting shall be carried out within 3 m of any underground utility without the prior written approval of the Engineer.

A report by a specialist Professional Engineer containing sufficient information to show that the proposed blasting can be done judiciously and safely shall be made available to the Engineer upon his request.

403.02.04 Tunneling

All tunneling shall meet the approval of the Occupational Health and Safety Inspector and the Provincial District Mines Inspector.

403.02.05 Utility Crossings - General

The Contractor shall be responsible for determining the precise location and elevation of all sewer, water and gas mains, electric light, power or telephone conduits and other structures and utilities.

The Contractor shall be responsible for notifying the appropriate representative of such utilities at least one week in advance of construction as outlined in The City of Calgary's *Standard General Conditions*.

Crossing, exposing, or excavating within three meters (3 m) of any feeder, force, or critical main requires an approval by Water Resources. The Engineer shall witness the pre-construction location and day-lighting of the Feeder, Force, or Critical Main's crown and sides unless otherwise approved, and shall subsequently attend and approve any proximity or crossing related excavation activities. The Consultant shall comply with the *Guidelines for Safe Construction in Proximity to Feeder mains, Critical Distribution Mains, Sewer Force Mains and Critical Collection Mains*. Contact Water Resources Project Engineering Underground at 403-268-5752 for requirements.

Crossing Over Existing Utility Lines

When crossing an existing utility which is located within 300 mm below the bottom of the trench the Contractor shall hand excavate and expose the existing utility. The existing utility shall be examined in the presence of the Engineer and owner of the utility. Any damage to the existing utility shall be repaired to the satisfaction of the Engineer and the utility owner. Before the pipe is laid, concrete haunching may be required as detailed on [Drawing 58: Pipe Support at Utility Crossing](#). If the existing utility was not damaged the sub-grade shall be re-established with approved granular material in 150 mm compacted layers. The finished grade shall be prepared accurately by means of hand tools.

Crossing Under Existing Sewer Main or Water Distribution Mains and Feeder mains

When crossing an existing sewer main, water distribution main or feeder main, the existing main shall be supported as detailed on [Drawing 58: Pipe Support at Utility Crossing](#) unless otherwise approved by the Engineer. Crossing of all other shallow and deep utilities shall be carried out to the satisfaction of the owner of such utilities.

403.02.06 Supported Trenches - General

When supports (such as trench sheeting, trench jacks, trench shields, or boxes) are used, ensure that support of the pipe and its embedment is maintained throughout installation. Ensure that sheeting, where required, is sufficiently tight to prevent washing out of the trench wall from behind the sheeting. Tight support of trench walls shall be provided below existing utilities or other obstructions that restrict driving of sheeting.

Supports Left in Place

Unless otherwise directed by the Engineer, sheeting driven into or below the pipe zone should be left in place to preclude loss of support of foundation or embedment zone material. When the top of the sheeting is to be cut off, a cut shall be made 500 mm or more above the crown of the pipe. Rangers, whalers, and braces shall be left in place as required to support cutoff sheeting and the trench wall in the vicinity of the pipe zone.

Timber sheeting to be left in place is considered a permanent structural member and shall be treated against biological degradation as necessary, and against decay if above the groundwater table. Certain preservative and protective compounds react adversely with thermoplastics, and their use should be avoided in proximity to the pipe material.

Moveable Trench Wall Support

The installed pipe and its embedment shall not be disturbed when using movable trench boxes and shields. Movable supports shall not be used below the top of the pipe zone unless an approved method is used to maintain the integrity of the embedment material. Before moving supports, place and compact embedment to sufficient depths to ensure protection of the pipe. As supports are moved, finish placing and compaction of embedment material.

Removable Trench Wall Support

Where sheeting or other trench wall supports are used within or below the pipe zone, ensure the foundation and embedment materials are not disturbed by support removal. Fill any voids left on removal of supports and compact all material to required densities.

403.03.00 INSPECTION

403.03.01 Inspection - General

All materials are subject to inspection and tests for soundness and suitability at the discretion of the Engineer. All work shall be inspected at the time of installation.

All work done in connection with these specifications is subject to inspection by the Engineer. The failure or neglect on the part of the Engineer, to condemn or reject inferior materials or work shall not be construed to imply an acceptance of the same should their inferiority become evident at any time prior to final acceptance of the work.

The contractor shall also furnish such labour as may be required by the Engineer to enable a thorough inspection and culling of all the materials and shall furnish reasonable samples of materials at the job to afford adequate testing.

The City of Calgary Inspector shall have access to all the work and the contractor shall cooperate with the Inspector in carrying out his duties.

403.03.02 Pipe Inspection - General

All sewer pipe shall be inspected to ensure the requirements set forward within the material specifications are met.

Pipe not conforming to the material specifications and this specification's standards for each type of pipe noted shall be rejected. All rejected pipe shall be marked with a 150 mm high 'X' adjacent to the manufacturer's marking.

Pipe delivered on site showing signs of repair shall be rejected unless the repair has been completed by the Manufacturer and accepted by the Engineer. The repair shall be sound, properly finished, cured and the repaired pipe shall conform to the requirements set forward in the approved material specifications. Concrete pipe, at delivery to the job site shall have cured and reach the design strength as required by ASTM C76 for non-pressurized pipe, ASTM C316 for low head pipe.

Pipe damaged during installation shall be repaired and the **consultant or manufacturers engineer** responsible for the repair shall conduct inspections as often as necessary to satisfy himself that the repair is done according to approved design and appropriate construction methods. A letter prepared by the attending engineer certifying that the structural integrity of the pipe is not compromised shall be submitted to the Engineer upon project completion.

For the type of pipe indicated, the following items shall be checked before any sewer pipe is installed.

Non-Reinforced Concrete Pipe

There shall be no variation in any dimension exceeding permissible variation given in ASTM C14 section 11.

Pipe shall be substantially free of fractures and excessive interior surface roughness.

Pipe shall be rejected for any of the following:

- Non-compliance to any clause within section 14 of ASTM C14.
- Damage to the pipe during the transportation and installation stages of construction. The damaged pipe may be repaired as noted in [403.03.02 Pipe Inspection](#).
- Bell and spigots that are broken for more than 4% of the external circumference.

Reinforced Concrete Pipe

There shall be no variation in any dimension exceeding permissible variation given in ASTM C76 (section 12) or ASTM C1417 (section 15) for pipe utilizing direct design.

Pipe shall be substantially free of fractures and excessive interior surface roughness.

Pipe showing exposure of circumferential reinforcement or if reinforcement has less than 25 mm cover shall be rejected.

For pipe designs utilizing 'Standard Installations Direct Design (SIDD) - ASCE #15', pipe shall be rejected for the following:

- There is a discrepancy between the embedment installation type (T1, T2, T3 or T4) stenciled on the pipe and that shown on the construction drawings.
- Depth of bury (H) which will occur is outside the range stenciled on the pipe.

Pipe shall be rejected for any of the following:

- Non-compliance to any clause within section 15 of ASTM C76 or section 16 of ASTM C1417 for pipe utilizing direct design.
- Damage to the pipe during the transportation and installation stages of construction. The damaged pipe may be repaired as noted within the [403.03.02 Pipe Inspection - General](#) clauses.

- Bell and spigots that are broken for more than 4% of the external circumference.
- ***Pipe showing interior or exterior rust staining from internal corrosion reaching the pipe surface. Such pipe may be repaired on site as specified above and the work certified by the Manufacturer. Concrete in the stained area shall be removed to verify that a minimum of 25mm of concrete embedment exists between the surface and the internal origin of the rust bloom. If the source of rust bloom is a minor deficiency such as a poorly positioned wire-tie or cage chair, the metal shall be removed and the removed concrete restored with a mortar repair as specified by the Manufacturer. If the source is a miss-aligned cage resulting in less than the required minimum 25mm concrete cover over all steel components, the pipe shall be clearly marked by the Inspector as “Rejected” and removed from the site by the Manufacturer.***

Solid Wall PVC Pipe and PVC Profile Pipe

Solid wall PVC pipe shall meet the physical requirements given in ASTM D3034 and CSA Standard B182.2.

PVC Profile pipe shall meet the physical requirements given in CSA Standard B182.4.

The pipe shall be homogeneous throughout and free from visible cracks, holes, foreign inclusions or other injurious defects. The pipe shall be as uniform as possible in colour, opacity, and other physical properties. PVC pipe showing evidence of UV degradation with a production date of more than **24** months previous to the proposal installation date shall be considered unacceptable.

Corrugated Steel Pipe

- Pipe shall not be dented, scratched or otherwise damaged. Any damage to the pipe or coatings shall be repaired as required by the manufacturer or as outlined in CSA G401, subject to acceptance of the repair by the City.
- Pipe shall be transported and stored in a manner that prevents the formation of Storage Stains. Pipes having Storage Stains exceeding the limits as permitted in CSA G401 shall be rejected until repaired to the satisfaction of the City.
- Pipe shall be handled in a manner that will not result in damage to the pipe or coatings. Pipe shall be lowered into the trench by using fabric slings or rope. Wire cables, metal chains or grapples shall not be used for handling pipe.

403.03.03 Verification of Proposed Construction Method Consistent with Design Intent

Project specific design requirements for the in-place density of outside bedding material, haunch material, and initial backfill shall be noted on the plans or in the project specifications. The precise measurement of these densities in place during construction is often not technically feasible. For example, a Type 2 installation (see [403.04.00 Foundation and Embedment Installation](#)) with Class IA or IB materials as defined herein and in ASTM D2321. The maximum bedding material density of Class 1 aggregates shall be determined by ASTM 04253 and a drop test shall be performed at the start of each project, certified by the

Consultant and acceptable to the Engineer, confirming that the material achieves a minimum compaction of 90% of maximum density when placed. A sieve analysis of the material shall be carried out at the same time. The Engineer will have the ability to require further on-site testing (trial compaction demonstration and/or sieve analysis) for any questionable materials.

Using the previous example of a Type 2 installation, Class II material must also obtain 90% Standard Proctor Density after placement in the trench. If designers, contractors and aggregate suppliers wish to use Class II material without extra compaction they must ensure that dumped density tests are carried out prior to the start of a project. The Engineer will have the ability to require further on-site testing at any time. Class III material has more than 12% passing the No. 200 sieve and would require compaction to achieve 95% Standard Proctor Density.

Should the materials proposed for use in the embedment zone change during the course of the works, the installer shall notify the Engineer and carry out additional compaction trials sufficient to demonstrate that their proposed method of placement is consistent with achieving the specified requirements.

The trial compaction demonstration, whether or not it is carried out, shall in no way relieve the contractor from their contractual requirement of meeting the minimum performance criteria for completed installations as specified herein.

403.04.00 FOUNDATION AND EMBEDMENT INSTALLATION

403.04.01 Foundation Installation

The foundation soil shall be moderately firm to hard in-situ soil, stabilized soil, or compacted fill material. When unsuitable or unstable material is encountered, the foundation shall be stabilized using Class IA material (40 mm maximum particle size) and filter fabric if required (see [402.11.00 Foundation Stabilization Material](#)).

Subject to Water Resources approval, pit run gravel may be used on a project instead of Class IA material, provided a written request from a Specialist Geotechnical Engineer is received certifying the pit run material and there are less than 12% fines by mass passing the 0.075 mm (#200) sieve size.

Where groundwater and soil characteristics may contribute to the migration of soil fines into or out of the foundation, embedment soils, side fill, and/or backfill materials, methods to prevent migration shall be provided (see [402.10.00 Embedment Material](#)).

403.04.02 Embedment Installation

The installation of pipe embedment for both concrete pipe and flexible pipes (PVC and PVC profile pipes) shall be based on ASTM D2321 and the following modified ASCE 15 Standard Installation Types as shown in [DRAWING 33 BEDDING AND BACKFILL DETAILS FOR RIGID PIPE](#) and [DRAWING 33B BEDDING AND BACKFILL DETAILS FOR FLEXIBLE PIPE](#) of these specifications (also see [402.10.00 Embedment Material](#)).

Where an on-site material is used in the initial backfill zone in accordance with [DRAWING 33 BEDDING AND BACKFILL DETAILS FOR RIGID PIPE](#) and [DRAWING 33B BEDDING AND BACKFILL DETAILS FOR FLEXIBLE PIPE](#).

Approved warning tapes shall be installed 300mm above the crown of the pipe. Two tape runs shall be laid with the inner edge of each tape positioned over the opposite sides of the main.

Type 1 Installation

Embedment installation shall achieve a minimum of 95% Standard Proctor utilizing Class 1A or 1B material. Type 1 installation requires that the material, density and method of installation be CERTIFIED by a Professional Engineer. The acceptance of a Type 1 installation will be approved only on a case by case basis.

Type 2 Installation

Embedment installation shall achieve a minimum of 90% Standard Proctor utilizing Class 1A, 1B, or II material or shall be compacted to a minimum of 95% Standard Proctor utilizing Class III material.

Type 3 Installation

Embedment installation shall achieve a minimum of 85% Standard Proctor utilizing Class 1A, 1B, or II material or shall be compacted to a minimum of 90% Standard Proctor utilizing Class III material.

Type 4 Installation

Embedment installation with no extra compaction utilizing Class 1A, 1B, II or III material, or compacted to 85% Standard Proctor utilizing Native Materials. In a Type 4 installation no bedding is required except in a rock foundation where minimum bedding thickness shall be $D_o/12$ (not less than 150 mm). Type 4 installations shall be limited to appropriately designed concrete pipe.

Embedment Details

Embedment materials shall be as noted herein (see also Drawings 33 and 33B: Bedding and Backfill Details for Rigid and Flexible Pipe) and [402.10.00 Embedment Material](#)) except that for profile pipe, Class 1A, 1B, II and III maximum aggregate size shall be 20 mm.

	Solid Wall PVC		Profile Wall PVC/PolyP	Concrete	
	375 mm and Smaller	Larger than 375 mm	All Sizes	375mm and Smaller	450mm and Larger
Maximum allowable size for all bedding material classes (see 402.10.01 Bedding Material)	20 mm	40 mm	*20 mm	20 mm	40 mm

* Note: 20 mm is required **for profile pipes** in order for the aggregate to fit between the ribs. This enhances pipe support and minimize voids. All other embedment installation **procedures** for PVC **and PolyP** profile pipes are the same as PVC DR 35, solid wall pipe.

HDPE Sanitary Sewer Forcemain Pipe

For embedment installation of sanitary sewer forcemain applications, refer to section 504.03.01 of *Standard Specifications Waterworks Construction*. For Bedding Classifications, refer to *Standard Specifications Waterworks Construction*, Sht. #39.

403.04.03 Bedding

Bedding shall be constructed as required by the project specifications and in accordance with the contractors proposed construction method as verified in the compaction trial demonstration.

The bedding layer shall be placed as uniformly as possible to the required density, except that loose, un-compacted material shall be placed under the middle third of the pipe, prior to placement of the pipe.

Bell holes shall be excavated in the bedding when installing pipe with expanded bells such that the barrel and not the bell supports the pipe.

For large diameter pipe with D_o greater than 2400 mm, minimum bedding thickness shall be $D_o/24$ (not less than 100 mm).

If there is a rock foundation, then minimum bedding thickness shall be $D_o/12$ (not less than 150 mm).

403.04.04 Haunch and Initial Backfill

Placement of haunching and initial backfill embedment materials shall be carried out by methods that will not disturb or damage the pipe.

The haunching material shall be carefully worked in and tamped in the area between the bedding and the underside of the pipe before placement of the remainder of the material in the embedment zone.

If compaction is required, compaction equipment and methods shall be compatible with the materials used, the location in the trench, and the in-place densities required.

The primary purpose of initial backfill is to protect the pipe from any impact damage that may arise from the placement of overfill materials. Minimum thickness of cover over the top of the pipe shall be 300 mm as indicated on Drawings 33 and 33B: Bedding and Backfill Details. Where final backfill contains large objects or is required to be deposited from very high heights, initial backfill shall be extended to such additional height above the pipe as is necessary to prevent damage from occurring to the pipe during backfilling operations.

Before using heavy compaction or construction equipment directly over the pipe, ensure that sufficient backfill has been placed over the pipe to prevent damaging either the pipe or the embedment zone materials.

For rigid (concrete) pipe the final backfill shall be the specified embedment material (see [DRAWING 33: BEDDING AND BACKFILL DETAILS FOR RIGID PIPE](#), or pit run gravel, or select native material, that meets basic criteria for backfill/pipe overfill, and is compacted to the specified density for the 'Installation Type' being installed.

In a flexible pipe installation, the material for initial backfill shall be the same as the embedment material (see [DRAWING 33B BEDDING AND BACKFILL DETAILS FOR FLEXIBLE PIPE](#)).

Pit run gravel and select native material shall be devoid of boulders, organic matter, frozen material, lumps, debris or other material injurious to the pipe.

403.04.05 Change in Native Soil Conditions

Should a change in site conditions are observed that would impact either short or long-term pipe and/or embedment soil performance, the contractor shall notify the Engineer, so that the validity of the original design concept can be reviewed by the Engineer. If necessary, the design will be modified to suit the actual conditions encountered in the field.

403.04.06 Final Backfill

The final backfill shall be approved material containing no debris, organic matter, frozen material, large stones or other objects that may be detrimental to the pipe or the embedment materials. The contractor shall ensure there is sufficient cover over the pipe and the embedment zone materials to facilitate subsequent construction operations associated with the placement and compaction of final backfill.

403.04.07 Manhole Bedding

Precast Manholes

Precast manhole bases shall be bedded on a maximum 150 mm of Class II material (maximum size 40 mm) or acceptable undisturbed foundation material.

Cast- in-Place Manholes

Concrete bases shall be poured on a maximum 150 mm of Class II material (maximum size 40 mm) or acceptable undisturbed foundation material.

403.04.08 Concrete Drainage Swale

All concrete swales shall be placed on undisturbed foundation material or on material compacted to a minimum of 97% of the soil's standard proctor density.

403.05.00 PIPE INSTALLATION

403.05.01 General

Sewer pipe shall not be placed on bedding containing frozen, unsuitable, or unstable material.

Sewer pipe shall be laid to the alignment and grade shown on the approved construction plans. Sewer pipe shall be laid from the lower end of the line, upward with the bell end facing upwards.

When bell and spigot pipe is used, the bell end shall be laid upgrade and shall have a recess excavated in the bedding to receive the bells. Sewer pipe is to be laid having the entire length supported by the bedding material.

All pipes shall be laid with the joints close and evenly abutting all around the pipe. A true even surface must be obtained along the invert of the joints.

For all curved sewers (concrete, PVC, and Profile PVC), joint pulls shall not exceed 13 mm. For curved concrete pipe where required joint pull exceeds 13 mm, approval must be requested from Water Resources.

On gasket equipped round concrete pipe, joint pulls shall not exceed 13 mm. On such concrete pipe where required joint pull exceeds 13 mm, a case by case approval may be given by Water Resources to exceed a 13 mm joint pull if the request is accompanied by test results demonstrating the specific gasket product hydrostatic integrity can be maintained at gaps greater than 13 mm joint pull by holding 90 kPa water pressure for 10 minutes without leakage. A one meter wide concrete collar at each joint with #10 gauge mesh reinforcement will be required in this case.

Other options for construction of curved concrete sewers not requiring case by case Water Resources approval include the use of beveled joints, special pipe bends, radius pipe and/or additional manholes. Curved concrete pipe alignments are discussed in detail in American Concrete Pipe Association (ACPA) Design Data 21.

If in the process of making joints, previous lengths are moved or disturbed so as to cause the gasket to move or joint to break, the pipe joint shall be remade.

When installing gaskets all sewer pipe ends shall be thoroughly cleaned and lubricated with a lubricant recommended by the manufacturer.

When gaskets have been affixed, the pipe shall be handled so that the gasket is not damaged, displaced or contaminated with foreign material.

All alterations to sewer pipe shall be done by cutting or coring, unless approved by the Engineer.

Cover over sanitary and storm sewer mains and services shall conform to the minimums as noted in Design Guidelines for Subdivision Servicing – Wastewater / Stormwater.

403.05.02 Sanitary Sewer Pipe

All pipe installed shall be made as watertight as possible using rubber gaskets to the manufacturer's specifications.

Ground water and surface runoff from any source shall not enter or be pumped into the City sanitary sewer system or to the surface without the required Drainage or De-Watering Permit. All chlorinated or potable water shall be dechlorinated to the satisfaction of the Engineer prior to discharge. Violations of applicable Federal and Provincial Acts and City Bylaws will be subject to the penalties listed therein.

All open pipes must be blocked with approved plugs preventing water from entering the sanitary sewer system. Blocking is to be done when required by the Engineer and includes, but is not limited to the following cases:

- When a stub is to be buried and left for future tie-ins
- At the end of the working day
- When rain occurs

403.05.03 Storm Sewer Pipe

All pipe installed shall be made as watertight as possible using rubber gaskets to the manufacturer's specifications, unless otherwise approved by the Engineer.

Ground water and surface runoff from any source shall not enter or be pumped into the City storm sewer system or to the surface without the required Drainage or De-

Watering Permit. All chlorinated or potable water shall be dechlorinated to the satisfaction of the Engineer prior to discharge. Violations of applicable Federal and Provincial Acts and City Bylaws will be subject to the penalties listed therein.

Blocking is to be done when required by the Engineer and includes, but not limited to, the following case: when a stub is to be buried and left for future tie-ins.

403.05.04 Corrugated Steel Pipe - Round

Note: This section should be used in conjunction with *Standard Specifications: Road Construction*, section 320.00.00, Agricultural Crossings.

General

The pipe shall be placed with the inside circumferential laps pointing downstream and with the longitudinal laps at the sides.

Strutting when necessary shall be installed and removed according to the pipe manufacturer's recommendations.

At the discretion of the Engineer, **groundwater** plugs shall be installed to prevent water migration where granular bedding is used.

Corrugated steel pipe shall be jointed according to the manufacturer's recommendations.

Field repairs shall be undertaken according to the manufacturer's recommendations.

Excavation and Base Preparation

Excavate down to 300 mm below intended pipe invert in accordance with [403.02.00 Excavation](#). Excavate to a width sufficient to permit pipe assembly and accommodate bedding placement and compaction equipment on both sides of the pipe assembly.

Carefully trim bottom of excavation to provide uniform support along the profile and throughout the length of pipe. Compact base to a minimum 95% Standard Proctor density. If base is too soft to compact, continue excavation to firm base and backfill with granular or other material approved by the Engineer compacted in 150 mm lifts to a minimum 95% of Standard Proctor Density.

Place granular bedding in lifts of 150 mm when compacted. Compact each lift to a minimum 95% of maximum density according to ASTM D698 Method A. Loosen the top 50 mm of bedding in contact with the pipe to permit the corrugations to seat snugly.

Pipe Installation

Note: pipe may have very sharp edges. Sturdy gloves must be worn at all times when handling corrugated steel pipe.

- Lift pipe into the trench using methods that do not result in damage to the pipe or coatings. Use of slings supporting the pipe at both ends is recommended. Place the pipe as close as practical to the final location to minimize the amount of manipulation required.
- Carefully assemble the joint. Confirm that pipe inverts match as to grade and line. Install the gasket ensuring that the gasket is evenly placed around both pipe ends. Do not displace the pipes while installing the gasket.
- Install and tighten the coupler. Do not allow the pipe to be "pulled" into line or grade when

the coupler is tightened. Tighten bolts evenly to avoid twisting or distorting the coupler. Ensure the gasket is being evenly compressed and is not bunching or pinching under the coupler.

- Couplers do not permit joints to be angled in order to achieve a curve. Curves may only be achieved by installing manholes and creating the required angle through the manholes.
- Connections to manholes is either by means of a flexible “boot” type connector designed to suit corrugated steel pipe, or by use of mortar.

Backfill

Do not cover work until it has passed inspection by the Engineer. Correct deficiencies as directed.

Backfill according to [403.07.00 Backfilling](#) as modified below.

Do not drop material onto the pipe as this may damage the coatings – place the material adjacent to the pipe.

Place granular backfill under pipe haunches on both sides of pipe in 150 mm lifts. Compact each lift to a minimum 97% of maximum density according to ASTM D698 Method A. Do not allow the levels of fill on the two sides to differ by more than one lift at any time.

Do not permit compaction equipment or other tools to strike the pipe.

Build up backfill until reaching a minimum cover of 300 mm over pipe. After compaction, the remainder of the embankment of roadway may proceed.

Do not allow construction and other traffic over the pipe unless adequate protective fill is placed in addition to the minimum cover. Remove such protective cover before proceeding with the rest of embankment fill.

For temporary construction vehicle loads (100 kips/axle load), place at least 1200 mm of compaction cover over the top of the pipe (but not exceed the maximum allowable cover of the pipe as recommended by the pipe manufacturer).

403.05.05 PVC Solid Wall and Profile Pipe

PVC pipe shall be installed according to ASTM D2321.

Regarding deflection requirements for PVC pipe, see [403.13.04 Deflection Testing](#).

PVC pipe shall be installed such that the spigot is inserted until the reference (insertion) mark on the barrel is even with the edge of the bell.

403.05.06 HDPE Pipe Bursting Procedures for Replacing Sanitary Services

Procedure for Sanitary Service Replacement: 12" Long Coupling

- 33) Pipe bursting head to be a minimum of 25% larger than the new pipe's outer diameter. Note: Consideration should be given to the pulling force exerted on the new pipe during installation. Tension on the new pipe should be kept to a minimum.
- 34) Apply appropriate amount of pipe lubricant to reduce drag on new incoming pipe. Use Yellow 77 (0 ° to 54 °C operating range), AquaGel (-32 ° to 82 °F operating range), or

approved equivalent (Westburne Electric is one supplier).

- 35) Pipe Joint will be well-fitted with a 1/8" maximum gap between pipe ends. The inside of the pipe to be deburred.
- 36) A pipe relaxation period of 4 hours minimum is required.
- 37) Couplings:
 - Coupling to be Fernco or approved equal.
 - Length - 12" (Corix part #S-116876).
 - Banded with six (6) stainless steel clamps/straps in total (see [Drawing 35A: PE Pipe Bursting \(San Service Repl.\) 12" Long Coupling](#)).
 - Pipe insertion into coupling to be 50% (see [Drawing 35A: PE Pipe Bursting \(San Service Repl.\) 12" Long Coupling](#)).
 - Concrete encasement is not required for saddle connections to PVC mains (i.e. flexible pipe).
- 38) Pits:
 - Pit and/or pipe to be properly bedded with drainage rock or pea gravel to a minimum of 150 mm above and below the pipe at the location of the coupling.
 - Covered during relaxation period to maintain temperature control.
 - Access pits to be maintained dry.
 - Proper ground thaw procedures followed as required.
 - Provide proper temporary connection when required.
- 39) Video Inspection to be done post installation and prior to release of indemnification agreement. Contractor to provide video post installation and The City of Calgary to provide video prior to release of indemnification agreement.
- 40) Inspection to be completed as required, typically at the job start for performance monitoring purposes and after relaxation.

Procedure - Sanitary Service Replacement: 4" Long Transition Coupling

- 41) Pipe bursting head to be minimum 25 percent larger than the new pipe outer diameter. Note: Consideration should be given to the pulling force exerted on the new pipe during installation. Tension on the new pipe should be kept to a minimum.
- 42) Apply appropriate amount of pipe lubricant to reduce drag on new incoming pipe. Use Yellow 77 (0° to 54 °C operating range), AquaGel (-32° to 82 °F operating range), or approved equivalent (Westburne Electric is one supplier).
- 43) Pipe Joint will be well-fitted with a 1/8" maximum gap between pipe ends. The inside of the pipe to be deburred.
- 44) A pipe relaxation period of 4 hours minimum is required.
- 45) Coupling:
 - Coupling to be Fernco #1056-44 or approved equal.
 - Length - 4" minimum. Longer couplings are recommended.
 - Banded with two (2) stainless steel clamps/straps on each end of the coupling (four (4) in total).
 - Pipe insertion into coupling to be 60 percent/40 percent (40 percent on

fixed/existing end) and 50 percent/50 percent for transition couplings. Polywrap and encase each connection in HS (Type 50) concrete (encase City end connection the next day).

- Concrete Encasement Requirements (see [Drawing 35B: PE Pipe Bursting \(San Service Repl.\) 4" Long Transition Coupling](#)):
- Length - 8" past coupling on new pipe and 4" past coupling on fixed end (16" total, based on a 4" long coupling).
- Diameter - 2" minimum thickness encasement surrounding pipe diameter.
- Concrete encasement is not required for saddle connections to PVC mains (i.e. Flexible pipe).

46) Pit:

- Pit and/or pipe to be properly bedded with drainage rock or pea gravel to a minimum of 150 mm above and below the pipe at the location of the coupling.
- Covered during relaxation period to maintain temperature control.
- Access pits to be maintained dry.
- Proper ground thaw procedures followed as required.
- Provide proper temporary connection when required.

47) Video Inspection to be done post installation and prior to release of indemnification agreement. Contractor to provide video post installation and The City of Calgary to provide video prior to release of indemnification agreement.

48) Interim video at one month and one year is recommended. City to provide videos. Inspection to be completed as required, typically at the job start for performance monitoring purposes and after relaxation.

403.05.07 Jointing of HDPE Pipe for Sanitary Sewer Forcemains

For jointing of HDPE pipe, please refer to section 504.04.11 of Standard Specifications Waterworks Construction.

403.05.08 HDPE Pipe Restraints for Sanitary Sewer Forcemains

HDPE pipe restraints shall be installed per *Standard Specifications Waterworks Construction*, Sheet #58.

*Note: Use of alternate procedures or materials requires approval from Water Resources.

403.05.09 Carrier and Encasement Pipe

When a major road crossing is constructed with a carrier and encasement pipe by an auger or open cut method, the encasement and carrier pipe shall be installed to the following standard:

Encasement Pipe

Standard wall steel pipe conforming to ASTM A53, with beveled ends for field butt welding. Coating and linings are not required. The encasement pipe shall have the following minimum diameter:

Carrier Pipe Nominal Inside Diameter (mm)	Encasement Pipe Minimum Nominal Diameter mm)	
	PVC or Steel Carrier	Concrete Carrier
150	300	300
200	400	450
250	450	500
300	500	600
375	660	710
450	750	810
525	810	910
600	865	1015
675	965	1115
750	1220	1220
900	1270	1420
1050	1320	1575
1200	1370	1625

Carrier pipes greater than 1200 mm require approval from the Engineer (see [Drawing 60: Encasement Pipe Detail](#)) for more Detail.

Carrier Pipe

Carrier pipe shall be solid wall PVC (bell and spigot) conforming to [402.01.01 PVC Pipe](#) or concrete pipe conforming to [402.01.01 Pipe](#) or other approved material. The carrier pipe shall be supported by approved casing spacers as per [402.01.03 Casing Spacers](#). A spacer shall be placed adjacent to each side of the pipe joint and at 0.3 and 2.0 m from each end of the casing pipe.

The spacers for the remainder of the pipe barrel shall not exceed 3.0 m. The spacer runners shall be at least 10 mm greater than the bell heights to ensure the pipe is not supported on the bell. The ends of the casing shall be covered with suitable fabric, PSI Model 'C' end seal or approved equal to the satisfaction of the Engineer. For PVC pipe, the spacer on the spigot end shall be placed in line with the insertion mark, to prevent over-insertion into the bell.

403.05.10 Frost Protection

When sanitary or storm sewer mains or services cannot be placed at the depth as specified in [403.05.01 General](#), the Contractor may, subject to the Engineer's approval, install the storm or sanitary main/service at a reduced depth providing that adequate insulation is provided to prevent freezing.

Approved insulation products: AggreLite, LiteWeight 730, Cematrix®, Styrofoam® High Load 40, Owens Corning Formular 400®, Plastispan 40, Beaver Plastics Terrafoam HS 40, Urecon® pre-insulated pipe or approved equal.

Sanitary insulation shall be installed per Section 504.04.15 Standard Specifications

Waterworks Construction.

Storm insulation shall be installed as detailed in [Sheet #64: SHALLOW BURY STORM INSULATION](#) using Urecon Pre-insulated pipe or Cematrix poured-in-place insulating fill to be designed and installed per manufacturer's recommendations. Alternately, installations per Standard Specifications Waterworks Construction, Sheets #53 and #54 (Cematrix®), #62 and #64 (approved rigid board insulations) are also acceptable.

Where proposed minimum covers are less than those permitted in the Standard Insulation Details, a site-specific insulation design supported by thermal modeling and stamped by a professional Engineer licensed to practice in Alberta shall be submitted for review and must be granted Approval prior to installation.

403.05.11 Precast Concrete Box Conduit (Duct)

Installation shall be in accordance to the latest edition of ASTM C1675 unless specified on this Specification and as shown on [Drawing 33A: Bedding and Backfill Details for Precast Concrete Box Conduit](#).

When unsuitable or unstable material is encountered, the foundation shall be stabilized or removed and replaced with firm and stable foundation material (see 402.11.00 Foundation Stabilization Material).

Each joint shall meet the infiltration and exfiltration specifications stated on the approved drawings, contract documents, or as shown in [Drawing 65: Precast Concrete Box Joint Treatment Guidelines](#).

In case of discrepancy, the more stringent specifications shall prevail as determined by the Engineer.

Precast concrete box sections shall be handled with reasonable care; not to drag over gravel or rock and to prevent box sections from striking rock or other hard objects during placement.

Placement and assembly of the box may proceed only after excavation, foundation, and bottom bedding material have been inspected and accepted by the Engineer.

All defects which will impair the structural integrity and performance of the sewer system shall be repaired prior to acceptance by the Engineer. This include but not limited to improper joints, cracked, sheared or excessively deflected pipe, sags and rises which pond water in excess of 35mm, protruding service connections and visible leaks. Precast box pipes with cracks 0.6mm or wider shall be rejected.

Acceptance of the completed sewer system shall be carried out in accordance to [403.13.00 Acceptance Testing](#), where applicable.

403.06.00 SERVICE CONNECTIONS

All pre-installed sanitary and storm services shall be located at the centerline of each lot (unless otherwise approved on the building grade plan). Service connections shall be installed to 5.0 meters inside the property line unless otherwise approved. Services installed to existing buildings shall be installed to best suit the existing interior plumbing.

In areas where weeping tile is not required and the native site material is predominantly clay, the water and sanitary sewer service lines shall be bedded and backfilled with a suitable

clay material from the water service valve to 5.0 m inside the property. This section may be referred to as a "**groundwater** plug" and is intended to act as a barrier to ground water movement in the service trench. Other section of service trench shall be installed in accordance with the following detailed drawings and specifications:

Item Description	Drawing
Typical Residential Service Installation	Drawing 34: Typical Residential Service Installation
Sewer Service Connections to Mains	Drawing 35: Sewer Service Connections to Mains
PE Pipe Bursting (San. Service Replacement) 300 mm Long Coupling	Drawing 35A: PE Pipe Bursting (San Service Repl.) 12" Long Coupling
PE Pipe Bursting (San. Service Replacement) 100 mm Long Transition Coupling	Drawing 35B: PE Pipe Bursting (San Service Repl.) 4" Long Transition Coupling
Standard Backfilling for Services	Drawing 36: Standard Back-Filling for Services
Service Connection Details for Sanitary Manhole in Cul-de-sac	Drawing 37: Service Connection Details for Sewer Manhole in Cul-De- Sac
New 5A Manhole on Existing Sewer	Drawing 38: Manhole Assembly

Service lines shall not be installed to sewer mains that are deeper than 6m to the pipe crown.

Sanitary and storm services shall be installed in conjunction with the water service unless otherwise authorized by the Engineer.

Service connections to flexible pipe may not be made to bent pipe. Where service connections to a curved sewer may occur, the curve shall be formed by deflections at the joints and not by bending of the pipe. The maximum joint deflection as stipulated by the manufacturer shall not be exceeded.

Holes into the sewer main shall be made between the spring line and the top of pipe. A hole approximately 10 mm larger than the outside diameter of the service connection shall be cut into the main to accommodate the service connection.

All 75 mm and 100 mm service lines shall be connected to the sewer main by one of the following methods:

- c) By use of a pre-installed in-line tee.
- d) By use of a saddle to a machine tapped (cored) hole.

Any sewer main fragments shall be removed from inside the sewer main prior to the installation of the connection.

Care shall be taken to ensure that no part of the saddle or service pipe protrudes beyond the inside surface of the sewer main.

Horizontal bends are not allowed unless approved construction drawings indicate otherwise.

A maximum of two vertical bends, one at property line and one at the sewer main will be

allowed. A 22.5° deflection in each bend shall be used.

Extra care shall be taken in backfilling and tamping around all services.

For HDPE pipe bursting requirements for replacing sanitary service lines, refer to the HDPE pipe bursting procedures for replacing sanitary services detailed in [403.05.06 HDPE Pipe Bursting Procedures for Replacing Sanitary Services](#).

403.07.00 BACKFILLING

403.07.01 General

Backfilling shall commence after the sewer, manhole or related structure has been installed to the approved standards.

Backfilling is to be carried out in such a manner that the placing of the backfill does not damage or disturb the pipe embedment, manhole or related structure.

Backfill material shall be free from frozen material, large clods, stones, extremely wet material and other deleterious material.

Where granular backfill material is used above the pipe embedment, this material shall conform to the specifications in section 303.00.00 of *Standard Specifications Roads Construction*.

Backfill material shall be placed in layers not exceeding the compaction capability of the equipment used to compact the material.

Compaction shall be achieved with suitable equipment capable of achieving the compaction requirements set forward within this specification. The equipment shall not damage the pipe, manhole, or related structure, or disturb the grade or line of each.

No more than 30 m of open excavation will be permitted in advance of pipe laying. Trenches shall be backfilled to final surface grade within 30 m of the front face of the pipe laying operation.

403.07.02 Sewer Pipe

The pipe embedment shall be placed in accordance with the construction drawings, [402.09.00 Cast in Place Concrete](#), [403.04.00 Foundation and Embedment Installation](#), [Drawing 33 Bedding and Backfill Details for Rigid Pipe](#) and [Drawing 33B Bedding and Backfill Details for Flexible Pipe](#).

Approved excavated material shall be placed at the next 450 mm above the pipe embedment before heavy mechanical compaction may be used to compact the remainder of the trench.

403.07.03 Sewer Duct

Backfill shall commence as soon as the structure has adequate strength to support the loads transferred to it by the backfill and compaction equipment.

403.07.04 Manholes and other Related Structures

Backfill shall commence as soon as the structure has adequate strength to support the loads transferred to it by the backfill and compaction equipment.

403.07.05 Groundwater Plugs and Weeping Holes at Storm Manholes

The purpose of the ground water plug and weeping holes is to provide a barrier to undesirable migration of groundwater in deep utility trenches and to provide for its diversion to the storm system.

Ground water plugs are to be installed when deemed necessary by the Geotechnical Consultant in areas where ground water migration must be controlled, or where directed by the Engineer. The location of installed ground water plugs shall be noted on the as-built drawing set.

Where required, the storm sewer located on the downstream side of a storm sewer manhole shall be bedded and back-filled with an impervious material such as a suitable clay or Control Low Density Fill as per Roads Construction Standard Section 304.05.00. The plug shall extend for a minimum distance of 3m in length from the manhole, unless otherwise designed and certified by the Consulting Geotechnical Engineer. A 75 mm diameter weeping hole shall be made on the manhole adjacent to the incoming storm sewer(s) at an elevation at or below the invert of the incoming pipe(s).

In areas where the watermain and or the sanitary sewer are higher than the storm sewer, a plug shall also be placed in each of these trenches. A 75 mm SDR 30 PVC sewer drain pipe shall be installed from the upstream side of a plug, at an elevation at or below the invert of the main(s), to connect the watermain and/or sanitary sewer trenches to the storm sewer trench. All plugs shall be installed as detailed on [Drawing 59: Ground Water Plugs and Weeping Holes at Storm Manholes](#).

403.08.00 BACKFILL COMPACTION REQUIREMENTS

The following shall apply to the compaction of all materials used for backfill.

403.08.01 Moisture Requirements

Soil used for trench or cut backfill shall be within +3% of its optimum moisture content. The Engineer may alter this requirement should soil conditions so dictate. Except for granular material shall be $\pm 3\%$ of optimum moisture content.

403.08.02 Density Requirements

Material in the pipe embedment shall be placed in accordance with the bedding type and material densities called for in [Drawing 33 Bedding and Backfill Details for Rigid Pipe](#) and [Drawing 33B Bedding and Backfill Details for Flexible Pipe](#).

Material in the Final Backfill, from 300 mm above the top of pipe to surface grade, shall be compacted to a minimum 97% of the soil's Standard Proctor density.

In the event of multiple installations of deep utilities (sanitary, storm, and water) in a common trench or where separate trenches overlap each other, the pipe embedment and corresponding density requirements shall be considered as the entire trench cross section from the lowest point in the excavation to 300 mm above the highest deep utility.

403.08.03 Tests for Compaction Control

The maximum density and optimum moisture content for each soil type shall be determined by ASTM D698.

The field density of soils shall be determined by ASTM D2922.

For spot checks, the following methods are also acceptable:

- ASTM D1556
- ASTM D2167
- ASTM D2216

Rapid drying of the soils to determine their field moisture content shall be permitted with a corresponding sample to be laboratory dried.

403.08.04 Testing Services and Reports

The following shall be the minimum acceptable standard for Testing Services and Reports.

- Tests shall be taken within 24 hours of the backfill being placed.
- Tests shall be so distributed that they are representative of the entire area of the backfill operations.
- 20% of the total number of tests shall be adjacent to manholes.
- Each test shall include the soil density and moisture content of the material, location of the test, and date when test was taken and backfill material placed.
- A test shall be taken on each 0.5 m of trench depth for a maximum of 75m.
- Two (2) tests shall be taken on each service trench.

403.08.05 Backfill Compliance Certificate

Certification that backfill and compaction work have been completed (in accordance with [403.07.00 Backfilling](#) and [403.08.00 Backfill Compaction Requirements](#)) shall be submitted to the Engineer prior to the issuance of the Construction Completion Certificate (CCC).

403.09.00 MANHOLES

403.09.01 Manholes - General

Manholes are to be constructed as shown on [Drawing 38: Manhole Assembly](#) and [Drawing 38C: New 5'A' Manhole on Existing Sewer](#) or approved construction plans.

The construction of manholes shall be coordinated with the main installation. Within one day of laying pipe up to a manhole, construction of the manhole shall commence.

All sanitary manholes shall be made as watertight as possible. All barrel joints and pipe connections shall also be made watertight.

Where maximized access to pond control chambers or structures such as large OGS units is specified, the manhole access shall be structured to accept and be supplied with a maximum access frame and cover as per Sheet 1B.

Manhole barrels delivered on site showing signs of repair shall be rejected unless the repair has been completed by the manufacturer and approved by the Engineer. The repair shall be sound, properly finished and cured.

Manhole barrels shall be substantially free of fractures and shall be rejected for any of the following:

- Non-compliance to any clause within Section 15 of ASTM C478.
- Damage to the manhole barrel during the transportation and installation stages of construction. The damaged manhole barrel may be repaired as noted within this section.
- Bell and spigots that are broken for more than 4% of the external circumference.
- Showing exposure of circumferential reinforcement or if reinforcement has less than 13 mm cover.

Manhole barrels damaged during installation shall be repaired and the **consultant or manufacturer's engineer** responsible on the repair shall conduct inspections to satisfy himself that the repair is done according to approved design and appropriate construction method. A letter prepared by the attending structural engineer certifying that the structural integrity of the manhole assembly or parts thereof is not compromised shall be submitted to the Engineer upon project completion.

403.09.02 Manhole Bases

Bases shall be constructed as shown on [Drawing 10: Precast Manhole Base Type 5 'A'](#) through [Drawing 20: Skimming Manhole Base](#). Cast-in-place manhole bases shall be constructed on suitable undisturbed material or a maximum 150 mm of Class II material (maximum size 40 mm).

Pre-cast manhole bases shall be installed on suitable undisturbed foundation material or a maximum 150 mm of Class II material (maximum size 40 mm). The bedding shall be shaped to support the bottom of the base. All pre-cast manhole bases shall be constructed with rubber gaskets or an approved equivalent sealant material.

403.09.03 Connections

Openings for connections into the manhole or catch basin barrel shall, when possible, be pre-formed at the manufacturing plant. Pre-formed openings shall be provided with sleeves to accommodate a boot connection or approved cast-in-place gaskets for use with the intended pipe size and material.

Openings for connections made in the field shall not be greater than the outer diameter of the pipe by more than 50 mm in any direction and shall be cored or cut. Remediation in excess of 50 mm shall be subject to approval by Water Resources.

Concrete pipe shall be centered within the opening. Only concrete brick and appropriate non-shrink mortar per [402.06.04 Mortar](#) shall be used to fill voids around concrete pipes. Clay bricks, stones, and rubble shall not be used. The inside wall of the opening shall have a smooth mortar finish as described in [403.09.03 Pipe Protrusion](#). Parging of brick and mortar connections must be completed on the exterior of connections.

When connecting PVC pipe to a manhole or catch basin, the following approved methods may be used:

- 49) Gasket or sleeve cast into a pre-formed opening at the manufacturing plant (preferred for pipe sizes where there is availability)
- 50) Approved manhole coupling and gasket shall be placed at the pipe manhole junction. Non-shrink mortar shall then be placed between the manhole coupling

and the manhole barrel.

51) An approved manhole adaptor gasket shall be placed into the manhole opening and the pipe is pushed in. The gasket must be sized and made to fit in a cored or cast opening in a manhole.

52) For field-made openings, approved connector gaskets shall be placed around the PVC pipe. The connector gaskets shall be of the size that when placed on the PVC pipe, a snug fit is achieved between the gasket and the PVC pipe. The gasket shall be positioned in the opening within the manhole barrel. Non-shrink mortar shall then be placed between the PVC and the manhole barrel. **See 402.01.05 for approved water stop gasket products. Use of standard pipe bell gaskets placed on pipe exterior is not acceptable.**

All pipe-to-structure connectors shall be made from materials that meet ASTM C-923 and sized specifically for the type of pipe being used and installed in accordance with manufacturer's recommendations. All mechanical devices including bolt assemblies and take-up clamps require a minimum of 304 stainless steel material.

Refer to [402.01.05 Manhole Connections](#) for approved manhole or catch basin connector products.

Pipe Protrusion

Where the pipe enters a 5A manhole, the pipe shall be made flush with the inside manhole barrel and the openings shall be mortared flush with the pipe and inside manhole wall.

Where the pipe enters a large diameter manhole (1500mm to **3000mm** diameter), the pipe shall be flush with the inside manhole wall at the springline. Pipe protrusions at invert and obvert shall be mortared smoothly to avoid gaps and cracks, and to provide water tightness. It is recommended that the mortar be applied at approximately 45 to 75 degrees to the protruded pipe. The maximum protrusions vary with the size of pipe and diameter of the manhole and should not exceed the values indicated on [Drawing 18B: Max. Concrete Pipe Protrusion for Round Manholes](#).

Where the pipe enters a 1S manhole, the pipe shall be made flush with the inside of the manhole wall and the openings shall be mortared flush with the pipe and inside manhole wall.

Road Sub-Drain Connection To Storm Manhole Barrel

Where approved, road sub-drains shall tie into the manhole barrel. The sub-drain lead shall be laid in the catch basin lead excavation. The invert of the sub-drain lead shall match the crown of the catch basin lead. Installation shall be as shown on [Drawing 43D: Standard Connection of Road Sub-Drain to Storm Manhole Barrel](#).

403.09.04 Benching

Benching shall be constructed in accordance with [Drawing 39: Benching Standards for Sewer Manholes](#) or approved construction drawings. With the exception of dead-end manholes, all unused channels on pre-benched manholes are to be filled with concrete using sulphate-resistant cement Type HS (Type 50) in accordance with CSA A3001 or Type V in accordance with ASTM C150. Compressive strength shall be **35 MPa** at 28 days, trowelled and smoothly finished to match the existing benching to the satisfaction of the Engineer.

Sanitary

In all cases the outgoing pipe shall be extended to the back wall of the manhole. All other leads entering the manhole, except in pre-benched manholes, shall have the pipe form the invert through the benching from the inside wall of the manhole barrel to the centre line of the outgoing pipe.

Storm

The same benching shall apply as noted under Sanitary with the exception that the pipe is not required to form the channel for pipe diameter greater than 600 mm.

403.09.05 Steps

All steps shall be installed according to the dimensions and locations specified on [Drawing 38: Manhole Assembly](#) and [Drawing 38A: Manhole Assembly for Spigot-Up Installations](#). All manholes shall have a step placed directly under the manhole frame in such a manner that the steps cannot be pulled out from between the manhole frame and frame support.

403.09.06 Manhole Frame Setting and Adjustments

General

Materials used for setting and adjustment of frames shall be of good commercial quality. Use of miscellaneous random material, such as stones, wood blocks, etc., is not acceptable.

Precast collars shall be smooth and level, and shall not rock when stacked. Collars must be in good condition.

Mortar shall be to the design as noted in [402.06.04 Mortar](#), with only enough water to make the mix workable. The mortar shall be batch mixed in only such quantity as can be used before the mortar begins to set up. Mortar that is not sufficiently workable shall be discarded. Adding water to the mortar after it has started to set up is prohibited.

Mortar must completely fill any spaces between collars, and the top slab and frame, in order to provide a continuous bearing surface. Mortar must be trowelled smooth with the inside of the collars. Mortar must not be applied to the inside of the collars.

Collars and bricks must be installed in vertical alignment. The chimney must maintain a round or square configuration matching the inside of the frame. Off-setting the chimney due to misalignment of the manhole is not permitted.

Setting and Adjustments

Manhole frames shall be installed as shown on the following drawings:

- [Drawing 38: Manhole Assembly](#).
- [Drawing 38A: Manhole Assembly for Spigot-Up Installations](#).
- [Drawing 38B: 5A Manhole Assembly for Spigot-Up Installations](#).

For all manholes, frames shall be installed on a minimum of one 50 mm precast concrete collar ([Drawing 6: Precast Manhole Collar](#)) to a maximum height of collars, including mortar, not exceeding 305 mm. If additional height is required, an additional manhole barrel shall be installed. During setting and adjustment, collar thicknesses shall be maximized to reduce the number of joints between collars.

The slab top, collars and frame shall be level and true, and shall not rock when stacked. A layer of mortar, not exceeding 1.0 cm in thickness, shall be placed between the slab top, all collars, and the frame as a bonding and leveling course. **Alternatively, these connections may be made with approved sealant materials in the joints between the top barrel, slab top and collars. Where the slab top needs to be horizontally adjusted to match curb after being set, disturbing the mortar or sealant previously applied, a 9mm bead of butyl caulk shall be run around the inside corner joint of the top riser barrel and top slab.**

Acceptable materials include butyl sealant caulk, flexible butyl gasket materials in coil form as per Section 402.01.02 installed as per the Manufacturer's instructions. In freezing conditions butyl sealants must be kept at room temperature till just prior to setting of joints to ensure compressibility.

Where the height of adjustment does not permit use of a full precast collar, or the frame must be on an angle to suit the surface grades, one of the following shall apply:

- e) Use iron or steel wedges, brick, or a combination of wedges and brick to support the frame. Once correct height and grade has been confirmed, the full width of the space under the frame shall be filled with mortar, or mortar and brick, depending on the space required to be filled. The amount of mortar shall be minimized. It may be necessary to temporarily lift the frame in order to place the brick and mortar, so that the full bearing surface of the frame will be supported. Care must be taken when removing and reinstalling the frame to ensure height and slope is maintained.
- f) Use a mechanical adjustment ring (Trojan or approved equal). The adjustment ring must be installed in accordance with the Manufacturer's recommendations.
- g) **Use Cretex, LadTech or Lifesaver plastic adjustment ring systems installed in accordance with the Manufacturer's recommendations. Additional manhole step may be required at Engineer's request.**

403.10.00 CATCH BASINS

403.10.01 Single Barrel Catch Basins

The catch basin barrel shall be set to grade on a maximum 150 mm thickness of Class II material, maximum diameter 40 mm, as per [402.09.01 Concrete Formwork](#), thoroughly compacted or undisturbed suitable native material. **All catch basins shall be built on a precast monolithic base as per Sheet 31A.**

All pre-cast catch basins shall be constructed with approved sealant materials in the joints between the base and any riser barrel and between the top barrel and the slab top. Where the slab top needs to be horizontally adjusted to match curb after being set, disturbing the mortar or sealant previously applied, a 9mm bead of butyl caulk shall be run around the inside corner joint of the top riser barrel and top slab.

Acceptable materials include butyl sealant caulk, flexible butyl gasket materials in coil form as per Section 402.01.02 installed as per the Manufacturer's instructions. In freezing conditions butyl sealants must be kept at room temperature till just prior to setting of joints to ensure compressibility.

Where the catch basin lead enters the catch basin well, it must be sealed with mortar and be flush with the inside face of the well. The bottom of the well is raised with concrete so

that it is flush with the invert of the catch basin lead and slopes with a minimum gradient of 10% toward the invert of the lead. The catch basin benching must have a troweled surface finish.

All catch basin barrels shall be installed with four weeper holes, 75mm in diameter, equally spaced at 90 degrees located 400mm below the top of the barrel. A 500mm wide strip of non-woven geotextile fabric (minimum 200gm/m²) shall be wrapped around the exterior of the barrel, centered on the weeper holes and over lapped at the ends by a distance of 300mm.

Backfill should be clay below and Class II material, maximum diameter 40 mm as per [402.09.01 Concrete Formwork](#) above the lowest weeper hole invert, up to the level of asphalt or sod/loam placement.

All Single Barrel catch basins shall be installed in accordance with the following drawings:

Item Description	Drawing
Storm Catch Basin Type 'C' Assembly	Drawing 40: Storm Catch Basin Type 'C' Assembly
Storm Catch Basin Type 'K-2' Assembly	Drawing 42: Storm Catch Basin Type K-2 Assembly
Storm Catch Basin Type 'K-3' Assembly	Drawing 43: Storm Catch Basin Type K-3 Assembly
Standard Catch Basin Barrel Installation Detail	Drawing 43A: Standard Catch Basin Barrel Installation Detail

Frame Installation

Materials used for setting and adjustment of frames shall be of good commercial quality. Use of miscellaneous random material, such as stones, wood blocks, etc., is not acceptable. Precast collars shall be smooth and level, and shall not rock when stacked. Collars must be in good condition.

The joints between the slab top and any collar(s) shall be sealed butyl sealant caulk, flexible butyl gasket materials in coil form as per Section 402.01.02 installed as per Manufacturer's instructions, or ASTM C270 Type "M" mortar as per Section 402.06.04. In freezing conditions butyl sealants must be kept at room temperature till just prior to setting of joints to ensure compressibility. Due to the light weight of precast concrete frame collars, where flexible butyl gasket materials in coil form are used between collars, the cross-section of the material shall be a maximum of 12.5mm to ensure compressibility.

Mortar shall be to the design as noted in [402.06.04 Mortar](#), with only enough water to make the mix workable. The mortar shall be batch mixed in only such quantity as can be used before the mortar begins to set up.

Mortar that is not sufficiently workable shall be discarded. Adding water to the mortar after it has started to set up is prohibited. Butyl sealants shall be stored and applied at the temperatures specified by the Manufacturer.

Mortar must completely fill any spaces/gaps between collars the top slab and frame, in order to provide a continuous bearing surface. Excess mortar must be troweled clean off the inside of the collars. Mortar shall not be applied to the inside of stacked

collars in a manner to obscure the collar joints.

Collars and final adjustment bricks must be installed in vertical alignment. The chimney must maintain a round or square configuration matching the inside of the frame. Off-setting the chimney due to misalignment of the manhole or catch basin barrel is not permitted.

Catch Basin frames shall be installed as shown on the following drawings:

- [Drawing 40: Storm Catch Basin Type 'C' Assembly](#)
- [Drawing 41: Twin Storm Catch Basins Type 'C' Assembly](#)
- [Drawing 42: Storm Catch Basin Type K-2 Assembly](#)
- [Drawing 43: Storm Catch Basin Type K-3 Assembly](#)
- [Drawing 43A: Standard Catch Basin Barrel Installation Detail](#)
- [Drawing 43C: Standard Connection Of Road Sub-Drain To Catch Basin Barrel](#)
- [Drawing 44: Type 'C' Catch Basin in 250 Gutter](#)
- [Drawing 45: Type 'C' Catch Basin in 500 Gutter](#)
- [Drawing 45A: Type 'C' Catch Basin in a Concrete Drainage Swale](#)
- [Drawing 46: Standard Type 'C' Lane Catch Basin](#)
- [Drawing 47: Standard Type 'C' Catch Basin in Highway Swales or Ditches](#)
- [Drawing 48: Type 'C' Catch Basin in Low Profile Rolled Curb With 250 Gutter](#)
- [Drawing 49: Type 'C' Catch Basin in Low Profile Rolled Curb With 500 Gutter](#)
- [Drawing 50: Standard Type 'C' Twin Catch Basin in Highway Swales or Ditches](#)
- [Drawing 51: Type 'K-2' Catch Basin in Low Profile Rolled Curb with 250 Gutter](#)
- [Drawing 52: Type 'K-2' Catch Basin in Low Profile Rolled Curb with 500 Gutter](#)
- [Drawing 53: Typical Catch Basin Installation in 9.00 m Dished Lane](#)

Adjustments

Bonding of precast concrete surfaces with mortar is required. Where it is absolutely necessary to raise frames and side inlets above the slab top or final collar in order to meet the curb and gutter grade, the adjustments shall maintain the standard vertical distance of 165 mm from the top of the side inlet to the top of the grate next to the face of curb and an allowable tolerance of 25 mm. These adjustments are:

- h) ***For adjustments of 12 - 49mm the frame or inlet shall be supported by iron or steel wedges, or a combination of wedges and brick on corners as required, with mortar or concrete placed in the space or gap created by the adjustment. The mortar or concrete may be:***
 - i) ***placed at the time of adjustment, ensuring that all gaps between the frame and the collar or slab is completely filled in to provide a complete and uniform bearing surface for the frame***
 - ii) ***cast-in-place mortar formed and placed prior to placement of the frame***
- i) ***For adjustments of 50mm -150 mm, the frame or inlet shall be adjusted by:***
 - i) ***installing pre-cast concrete collar(s) placed and sealed with approved butyl sealants or mortar using a precast collars/spacer(s) Where necessary, final frame adjustment of 12 to 49 mm with iron wedges and brick as specified in***

- a) *above is permitted.*
- ii) *cast-in-place structural concrete formed and placed prior to placement of the frame*
- j) *For gross height adjustments of greater than 150 mm use a single 100mm catch basin ring on top of the existing barrel and no more than 2 precast collars under the frame.*
- k) *Use Cretex, LadTech or LifeSaver plastic adjustment ring systems installed in accordance with the Manufacturer's recommendations.*

403.10.02 Double Barrel Catch Basins

The procedure follows [403.10.01 Single Barrel Catch Basins](#), except that the setting of the first barrel in its gravel bed and the second barrel is set with mortar **or approved butyl sealant** onto the first barrel in such a manner to ensure both vertical and horizontal alignment. **The two barrel risers shall be bolted together with MSU Manhole Frost Strap Kit or approved equal, installed at 120 degree intervals along the circumference of the barrel joint to ensure vertical alignment is maintained, except in the case where spigot up barrels are supplied, where a rope style butyl sealant is used in the same manner as manhole barrels.**

403.10.03 Twin Barrel Catch Basins

The procedure follows [403.10.01 Single Barrel Catch Basins](#). The bottom of the well is benched to provide a 10% gradient toward the invert of the catch basin lead. The "twin barrels" are connected by a 250 mm diameter concrete or PVC pipe at a gradient of 2%. Where the pipe enters the catch basin well it is sealed with mortar and must be flush with the inside face of the well.

Twin barrels shall be installed in accordance with [Drawing 41: Twin Storm Catch Basins Type 'C' Assembly](#).

403.10.04 Catch Basins in Lanes

The procedure follows [403.10.01 Single Barrel Catch Basins](#), [Drawing 46: Standard Type 'C' Lane Catch Basin](#), and [Drawing 53: Typical Catch Basin Installation in 9.00 m Dished Lane](#), except that **a minimum 2.0 metre asphalt apron is placed around the side inlet and grates. The Engineer may require apron modification based on site conditions.**

403.10.05 Catch Basins in Highway Swales or Ditches

The procedure follows [403.10.01 Single Barrel Catch Basins](#), [Drawing 47: Standard Type 'C' Catch Basin in Highway Swales or Ditches](#), and [Drawing 50: Standard Type 'C' Twin Catch Basin in Highway Swales or Ditches](#), except that **a minimum 2.0 metre concrete apron shall be placed around the side inlet and grates. The Engineer may require apron modification based on site conditions.**

403.10.06 Curb and Gutter

Catch basins shall be installed in accordance with the drawings listed below:

Item Description	Drawing
Type 'C' Catch Basin in 250 Gutter	Drawing 44: Type 'C' Catch Basin in 250 Gutter
Type 'C' Catch Basin in 500 Gutter	Drawing 45: Type 'C' Catch Basin in 500 Gutter
Type 'C' Catch Basin in Low Profile Rolled Curb with 250 Gutter	Drawing 48: Type 'C' Catch Basin in Low Profile Rolled Curb with 250 Gutter
Type 'C' Catch Basin in Low Profile Rolled Curb with 500 Gutter	Drawing 49: Type 'C' Catch Basin in Low Profile Rolled Curb with 500 Gutter
Type 'K-2' Catch Basin in Low Profile Rolled Curb with 250 Gutter	Drawing 51: Type 'K-2' Catch Basin in Low Profile Rolled Curb with 250 Gutter
Type 'K-2' Catch Basin in Low Profile Rolled Curb with 500 Gutter	Drawing 52: Type 'K-2' Catch Basin in Low Profile Rolled Curb with 500 Gutter

Existing Curb and Gutter

Existing curb and gutter or combined sidewalk curb and gutter shall be broken out or cut as required to accommodate catch basin installation. Placement procedure will follow that specified for curb and gutter to be constructed.

Curb and Gutter to be Constructed

Placement of catch basins and allowable adjustments must be completed prior to the installation of any curb and gutter or combined sidewalk, curb and gutter.

The gutter slabs in all catch basin types shall be poured after the catch basin, frames and/or covers are in place.

The catch basin base slab shall be poured at the same time as the adjacent curb and gutter. The catch basin bottom slab shall be poured at the same time the connection to the storm sewer is made.

403.10.07 Catch Basin Leads

Excavation and Bedding

Excavation of trenches and bedding of pipe shall conform to the requirements in [403.02.00 Excavation](#) and [403.04.00 Foundation and Embedment Installation](#).

Where the soil is sufficiently firm to provide a solid foundation for the pipe, select native fine granular material may be used for embedment if free of lumps and stones and thoroughly tamped. If the floor of the trench at proper grade is of unsuitable material as determined by the Engineer, a minimum Type 2 installation shall be used for pipe embedment (see [402.09.00 Cast In Place Concrete](#), [403.04.00 Foundation and Embedment Installation](#), [Drawing 33 Bedding and Backfill Details for Rigid Pipe](#) and [Drawing 33B Bedding and](#)

[Backfill Details for Flexible Pipe.](#)

Pipe Installation

Pipe installation shall conform to the requirements set forward within [403.05.00 Pipe Installation](#). All catch basin leads shall be installed with rubber gaskets, approved equivalent sealant material or concrete encasement on a minimum slope of 2%.

Connections

At the manhole and catch basin, concrete catch basin leads must be flush with the inside face and well grouted to form a neat joint. Openings made for connections shall not be greater than the outer diameter of the pipe by more than 50 mm in any direction and shall be cored or cut. Remediation of openings in excess of 50 mm shall be subject to approval by Water Resources. Install a 75 mm weeping hole at the manhole connections for catch basin leads. Catch basin lead connections shall conform to [403.09.03 Connections](#).

Road Sub-Drain Connection To Catch Basin Barrel

Where approved, road sub-drains shall tie into the catch basin barrel. Connections to the catch basin lead are not permitted. If road sub-drain needs to be tied into the catch basin barrel at a lower elevation than the weeper holes, then a separate set of holes must be cored per [Drawing 43C: Standard Connection of Road Sub-Drain to Catch Basin Barrel](#).

Backfilling and Compaction

Backfilling and compaction shall conform to the requirements in [403.07.00 Backfilling](#) and [403.08.00 Backfill Compaction Requirements](#).

403.10.08 Concrete Drainage Swales

Concrete swales shall be installed in accordance with the following drawings:

Item Description	Drawing
Standard Drainage Swale	#32
High Back and Overland Escape Route	#32C

Note: Drawings for sidewalk and boulevard drainage crossings for separate and mono walk are available in Standard Specifications: Road Constructions, Sheet #46 and Sheet #48.

Construction Joints

Construction joints shall be cut at every 1.5 m by means of a marking tool or other approved method. Joints shall not be less than 30 mm in depth and 6 mm in width. The edges of the joint shall be rounded off with an edger having a radius of 6 mm.

Air Content and Compressive Strength

Concrete supplies shall conform to the following requirements for air content and minimum compressive strength.

Minimum Allowable Compressive Strength at 28 Days		
Percent Air Content	Class "A"	Class "B"
6	27.5 MPa	24.0 MPa

Minimum Allowable Compressive Strength at 28 Days		
7	26.0 MPa	22.65 MPa
8 and above	24.25 MPa	21.25 MPa

Class "A" Concrete

Shall be used in areas where streets are wider than 11 m and shall extend a minimum distance of 45 m behind the face of curb line on each street intersecting into a Class "A" category street or as designated by the Engineer.

Class "B" Concrete

May be used where the streets are 11 m wide or less or as designated by the Engineer.

The minimum allowable compressive strength shall be interpolated for values between reference points. Concrete not achieving the minimum allowable strength shall be removed and replaced.

Finishing

All concrete work shall meet the following tolerances:

- 53) The elevation of any given point shall not vary by more than 20 mm from the design grades.
- 54) The fluctuations in the alignment shall not be greater than 25 mm in 100 m.

Repairs

Repair of concrete swales will be permitted under the following conditions:

- 55) Cracks with vertical displacements.
- 56) Chips and spalled edges.
- 57) Displacement at a joint.
- 58) Random cracking.

The following two products are approved for the repair of concrete swales when applied according to the manufacturer's instructions:

- 59) Fusion Crete for repair of chips.
- 60) Tremco Vulkem 45 and 116 for repair of cracks and displacement of joints.

Replacement

Replacement of concrete swales is required under the following conditions:

- 61) Longitudinal cracks greater than or equal to 1.5 mm in width.
- 62) Any settled area greater than 12 mm depth and 3 m in length.
- 63) Any feature considered detrimental to swale performance or appearance.

All repairs are subject to the approval of the Water Resources Inspection team. The performance of these products and workmanship will be monitored on an ongoing basis.

403.10.09 Catch Basin ICDs

Catch basin ICDs shall be plate type and shall be installed as per [Drawing 43B: Catch Basin Inlet Control Assembly for Plate Type Control](#).

403.11.00 CONCRETE

403.11.01 Concrete Formwork

Preparation of Surface

All surfaces against which concrete is to be cast shall be thoroughly cleaned.

All forms shall be treated with a sealer and releasing agent prior to placement of reinforcing steel or other embedded items. Reinforcing steel, embedded items and construction joints shall be free of any release agents or form coatings.

Erection

Framework and False work shall be erected in strict accordance with the approved shop drawings.

Framework shall be checked prior, during, and after concreting for elevation, alignment and plumb. Any adjustments made before initial set of the concrete tolerances shall be set according to CSA A23.1.

Framework shall be constructed to CSA A23.1, ACI 347 and ACI SP-4.

Temporary ports or openings at the bottom of deep units shall be provided to facilitate cleaning and inspection.

Large continuous panels arranged in a neat, repetitious pattern conforming to the general lines of the structure shall be used.

Twenty mm chamfer strips shall be used on all exposed corners unless otherwise indicated.

False work shall be constructed to CSA S269.1.

Removal of Forms

Framework or shoring shall not be removed until the concrete has cured sufficiently to carry its own weight, together with any superimposed loads.

Notwithstanding the above, formwork shall not be removed for a period of 48 hours. Formwork shall be removed progressively.

403.11.02 Concrete Reinforcement

General

Deliver and store reinforcing steel in accordance with CSA A23.1. Deliver all reinforcement bundled, tagged and marked properly.

Use approved tags showing bar size, length and other information corresponding to markings shown on placement drawings.

Inspection

Concrete shall not be placed until the reinforcement work has been inspected and approved.

Field Bending

Field bending of reinforcement shall not be done except where indicated or authorized.

When authorized, all bending shall be performed by applying a slow and steady pressure. Bars that develop cracks or splices during or after bending shall be replaced.

Placement

Coordinate the placement of reinforcing steel with other work requiring concrete embedment.

Securely position reinforcing steel on chairs, bolsters, hangers and spacers, providing required clear concrete cover as indicated.

Maintain clear cover of concrete within a 6 mm tolerance.

For slabs on grade, footings or similar construction, concrete blocks or bricks may be used in place of chairs on approval of the Engineer.

Place sufficient number of chairs to support weight of workmen.

Secure all reinforcement against displacement within the tolerance permitted, according to ACI 315. Tie the reinforcement where spacing in each direction is:

- Less than 300 mm - tie at alternate intersections.
- 300 mm or more - tie at each intersection.

Field cut reinforcing bars to suit required openings.

Splicing

Splicing of bars, except where shown on drawings, is not permitted without the approval of the Engineer. When permitted, make field splices of overlap lengths as specified in ACI 315.

Welding

Reinforcing steel shall not be welded unless authorized in writing by the Engineer.

When authorized, weld to CSA W186. Use only welders qualified under the provisions of CSA W47.1.

Cleaning

Prior to placing concrete, ensure that all steel is clean and free from loose mill scale, excessive rust, dirt, oil and paint.

403.11.03 Structural Concrete

Surface Conditions

Prior to all concrete work, carefully inspect the installed work of all other trades and verify that all such work is complete.

Do not proceed with installation in areas of discrepancy until all discrepancies have been fully resolved.

Preparation

Remove all wood scraps, debris, ice and snow from the areas in which concrete will be placed. Thoroughly clean the area(s) to ensure proper placement and bonding of concrete.

Thoroughly wet the forms (except in freezing weather) or oil them, and remove all standing

water.

Thoroughly clean all transporting and handling equipment.

Before placing concrete, all equipment for mixing and transporting the concrete shall be cleaned of hardened concrete and foreign materials.

Concrete shall be placed as per CSA A23.1.

Interior struts, stays and braces, serving temporarily to hold the forms in correct shape and alignment pending the placing of concrete at their locations, shall be removed when the concrete placing has reached an elevation rendering their service unnecessary. These temporary members shall be entirely removed from the forms and not buried in the concrete.

Product Handling

Use all means necessary to protect structural materials before, during, and after installation.

In the event of damage, immediately make all repairs and replacements necessary to the approval of the Engineer.

Material Storage

Cement shall be stored in a suitable weather-tight building, silo, or bin and shall be protected from dampness.

Facilities shall be provided to permit sampling and inspection. Prior to use, representative samples shall be taken for testing:

- At the discretion of the Engineer.
- When cement has been stored for a period exceeding six (6) months after the date of manufacture.

Cement shall be rejected if it fails to meet any of the requirements of [402.09.03 Cement, Water and Additives](#). Cement that has been in storage more than 1 year after the original acceptance shall not be used.

Stockpiling

In stockpiling fine and coarse aggregates, care shall be taken to avoid the formation of high cones. Material being unloaded shall be distributed in layers to prevent segregation of the coarse material from the fine particles in the aggregate during hauling or handling. Remixing of the aggregate could be required to produce uniform grading.

403.11.04 Ready-Mixed Concrete Equipment

Concrete Plant

Bins with adequate separate compartments shall be provided in the batching plant for fine and for coarse aggregate. Each bin compartment shall be designed and operated so as to discharge efficiently and freely, with minimum segregation, into the weighing hopper. Means of control shall be provided so that, as the quantity desired in the weighing hopper is approached, the material can be stopped with precision.

Weighing hoppers shall be constructed so as to eliminate accumulations of tare materials and to discharge fully.

Indicating devices shall be in full view and near enough to be read accurately by the operator while charging the hopper. The operator shall have convenient access to all controls.

Scales in use shall be accurate to +/- 0.4% of the total capacity of the scale when static load tested.

The device for the measurement of the added water shall be capable of delivering to the batch the quantity required within the accuracy required in these specifications. The device shall be so arranged that the measurements will not be affected by variable pressures in the water supply line. Measuring tanks shall be equipped with outside taps and valves to provide for checking their calibration, unless other means are provided for readily and accurately determining the amount of water in the tank.

Mixers and Agitators

Mixers may be stationary mixers or truck mixers. Agitators may be truck mixers or truck agitators.

All stationary mixers shall be equipped with a metal plate (or plates), on which it is plainly marked the mixing speed of the drum or paddles and the maximum capacity in terms of the volume of the mixed concrete.

All truck mixers and agitators shall have a metal plate or plates attached in a prominent place, on which are plainly marked:

- The gross volume of the drum.
- The capacity of the drum or container in terms of the volume of mixed concrete.
- The minimum and maximum mixing speeds of rotation of the drum, blades, or paddles.

All truck mixers and agitators shall be equipped with a means to readily verify the number of revolutions of the drum, blades, or paddles.

All mixers shall be capable of combining the ingredients of the concrete within the specified time or the number of revolutions specified.

All agitators shall be capable of:

- Maintaining the mixed concrete in a thoroughly mixed and uniform mass.
- Discharging the concrete with a satisfactory degree of uniformity.

Mixing and Delivery

Ready-mixed concrete shall be mixed and delivered in accordance with the requirements set forth in ASTM C94, CSA A23.1 and shall be subject to all provisions herein relative to materials, strength, proportioning, consistency, measurement, and mixing.

Heating Equipment

The equipment required for heating materials or housing shall be of adequate capacity and shall meet the inspection requirements and operating conditions laid down by Provincial Acts and Regulations.

Protective housing shall:

- Be wind and weather-tight
- Be constructed of suitable materials such as plywood, tarpaulins, or heavy plastic sheeting on a substantial framework.
- Be of an adequate size, so that proper placing procedures and construction operations (such as formwork erection and removal) can proceed unhampered therein.

- Have suitable openings to allow entry for the concrete or other construction materials. Each such opening shall be designed so that it may be fully covered and closed as soon as the concrete is placed.
- Where heating is to be used, be constructed so that it is clear of the concrete and formwork at all points, so as to allow a uniform circulation of heat to all parts of the work.

The housing shall be completed and the heating system installed and in operation for a sufficient period (as determined by the Engineer) prior to the pour to prove adequacy of the equipment. The housing and heating equipment shall be able to establish and maintain the specified curing conditions during the pour and throughout the specified curing period.

Mixing

Ready-mixed concrete shall be mixed and delivered to the point designated by the purchaser by means of one of the following operations:

- Central-mixed concrete is mixed completely in a stationary mixer and the mixed concrete transported to the point of delivery in a truck agitator or in a truck mixer operating at agitating speed or in non-agitating equipment approved by The City of Calgary.
- Shrink-mixed concrete is mixed partially in a stationary mixer, and the mixing completed in a truck mixer.
- Truck-mixed concrete is mixed completely in a truck mixer.

When the concrete is shrink mixed or truck mixed, the volume of mixed concrete shall not exceed 63% of the total volume of the drum or container.

Mixers and agitators shall be operated within the limits of capacity and at the speed of rotation designated by the manufacturer of the equipment.

Mixing Requirements

Under normal ambient weather conditions the concrete shall:

- Be mixed for a minimum of 10 minutes or a minimum of 50 revolutions of the drum at mixing speed before placing.
- Be deposited in the forms within 90 minutes, or before the drum has been revolved 300 revolutions, whichever comes first, after the introduction of mixing water, cement and aggregate.

The maximum number of drum revolutions at mixing speed shall not exceed 100, after which all revolutions shall be at agitating speed.

The rate of delivery of the mixed concrete shall be such that the interval between placing of successive batches shall not exceed 30 minutes.

Proportioning

Cement

Except as otherwise specifically permitted, cement shall be by weight. It shall be weighted on a scale or in a weigh hopper which is separate and distinct from those used for other materials.

When the quantity of cement in a batch of concrete exceeds 30% of the full capacity of the scale, the quantity of cement as indicated by the scale shall be within $\pm 1\%$ of the required weight. For smaller batches, to a minimum of 1 cubic metre, the quantity of cement used shall not be less than the required amount nor more than 4% in excess.

Under special circumstances approved by the purchaser, cement may be measured in bags of standard weight. No fraction of a bag of cement shall be used unless weighed.

Aggregate

Aggregate shall be measured by weight. Batch weights shall be based on dry materials and shall be the required weights of dry material plus the total weight of moisture (both absorbed and surface) contained in the aggregate. The quantity of aggregate used in any batch of concrete (as indicated by the scale) shall be within $\pm 2\%$ of the required weight when weighed in individual aggregate weigh batches. In a cumulative amount, when the scale is used in excess of 30% of scale capacity, the tolerance shall be $\pm 0.3\%$ of scale capacity or $\pm 3\%$ of the required cumulative weight, whichever is less.

Water

Mixing water shall consist of water added to the batch, ice added to the batch, water occurring as surface moisture on the aggregates, and water introduced in the form of admixtures. The added water shall be measured by weight or volume to an accuracy of 1% of the required total mixing water. Added ice shall be measured by weight. In the case of truck mixers, any wash water retained in the drum for use in the next batch of concrete shall be accurately measured; if this proves impractical or impossible the wash water shall be discharged prior to loading the next batch of concrete. Total weight (including any wash water) shall be measured or weighed to an accuracy of $\pm 3\%$ of the specified total amount.

Admixtures

Powdered admixtures shall be measured by weight, and paste or liquid admixtures by weight or volume. Volumetric measurement shall be with an accuracy of $\pm 3\%$ of the required amount or 30 mL, whichever is greater. Weighing accuracy shall be within $\pm 3\%$ of the required weight.

Admixture dispensers of the mechanical type capable of adjustment for variation of dosage, and of simple calibration, are recommended.

Air entrainment agents must be added to the batch independently. Sufficient air entrainment agent shall be added to produce the air content percent as specified, at the time of placing in the forms.

Re-tempering

Concrete shall not be re-tempered if test values are within specifications at the time of delivery to the site.

Concrete may be re-tempered at the job site with water and/or air entraining agent if the following requirements are met:

Mixing time after the admixture or water has been introduced shall not be less than 3 minutes at mixing speed.

Total mixing and agitating time for the load shall not exceed 90 minutes or 300 revolutions of the drum.

Re-tempering shall not be permitted unless first approved in writing by the Engineer.

403.11.05 Placing Concrete

Method

Convey concrete from mixer to place of final deposit by methods that will prevent separation and loss of materials.

For chuting, pumping, and pneumatically conveying concrete, use only equipment of such size and design as to ensure a practically continuous flow of concrete at the delivery end without loss or separation of materials.

Deposit concrete as nearly as possible in its final position to avoid segregation due to re-handling and flowing.

Place concrete as dry as possible consistent with good workmanship, never exceeding the maximum specified slump.

Rate of Placement

Place concrete at such a rate that concrete is at all times plastic and flows readily between bare bars.

When placing is started, carry it on as a continuous operation until placement of the panel or section is complete.

Do not pour a greater area at one time that can be properly finished without checking; this is particularly important during hot or dry weather.

Concurrent Conditions

The temperature of the concrete at the time of placing shall be between 16° C and 24° C unless the Engineer directs otherwise in relations to ambient conditions, the type of work and the protective system in use.

The formwork, existing concrete and reinforcing steel against which the concrete is to be placed shall be above freezing temperature before the Engineer will authorize placing to commence.

The area in which the concrete is to be placed shall be preheated when the air temperature is 0° C or below, with live steam or moist hot air; this shall also remove the snow and ice and heat existing concrete to prevent the formation of a cold joint.

Concrete shall not be placed on a frozen subgrade or against frozen ground. All excavations shall be protected with appropriate covers, preventing the area where concrete will be placed from freezing.

The layout of batching and mixing plant and type of handling equipment shall be such that distance and time of transport of mixed concrete before placing is kept to the minimum to avoid heat losses.

The concrete shall be placed rapidly and evenly as near to its final position as possible to reduce the risk of segregation, flow lines and cold joints.

Vibration and Compaction

Concrete, during and immediately after depositing, shall be thoroughly compacted. The compaction shall be done by mechanical vibration subject to the following provisions:

- The vibrator shall be internal unless special authorization of other means is given by

the Engineer or as provided herein.

- The intensity of vibration shall be such as to visibly affect a mass of concrete of 25 mm slump over a radius of at least 450 mm.
- Vibrators shall be of a type and design approved by the Engineer. They shall be capable of transmitting vibration to the concrete at frequencies of not less than 7000 impulses per minute.
- A sufficient number of vibrations shall be provided to compact each batch immediately after it is placed in the forms. Sufficient standby equipment shall be provided to ensure that vibration will be continuous. A minimum of one space vibrator shall be available on the site for pours up to 12 cubic meters of concrete placed per hour, and at least two space vibrators for greater output. In the event of breakdown of vibrators, the output must be reduced to match the capacity of the available vibrators.
- Vibrators shall be manipulated so as to thoroughly work the concrete around the reinforcement and embedded fixtures and into the corners and angles of the forms. Vibration shall be applied at the point of deposit and in the area of freshly deposited concrete. Vibrators shall be inserted vertically at points uniformly spaced and not further apart than twice the radius over which the vibrators shall be inserted and withdrawn out of the concrete slowly. Vibration shall be of sufficient duration and intensity to thoroughly compact the concrete, but shall not be continued as to cause segregation. It shall not be continued at any one point, to the extent that localized areas of grout are formed.
- Good results will usually be obtained by allowing the vibrators to sink to their full depth on their own weight, and then withdrawing at the same rate. Vibrating for 5 – 15 seconds at points 450 – 750 mm apart, depending on the size of the vibrator, is normal and will produce better results than vibrating for longer periods at wider intervals.
- Vibrators must be inserted vertically for the full depth of the layer being placed and should be allowed to penetrate 50 – 100 mm into the previous layer provided the concrete still becomes plastic under vibration. On exposed concrete work where appearance is important, care must be taken to avoid penetration of vibrators into a lower layer of partially hardened concrete. This may cause a visible line of demarcation between the two lifts.
- Vibration shall be supplemented by such spading as is necessary to ensure smooth surfaces and dense concrete along form surfaces and in corners and locations impossible to reach with the vibrators.
- Vibrators shall not be used for pushing concrete from one place to another. Concrete shall be spaded into place of final deposit.
- Where placing operations would involve dropping the concrete more than 1 m, it shall be placed through "canvas elephant trunks" or galvanized iron chutes. Concrete shall not be raised at a rate greater than that for which proper vibration may be affected.
- The concrete surfaces shall be protected from rain until the final set occurs.

Curing

All concrete shall receive moist curing for a period of five days. One of the following methods shall be used as soon as the concrete has hardened sufficiently to prevent marring:

- Surface covered with canvas or other satisfactory material and kept thoroughly wet.
- Surface sealed with polyethylene sheeting at least six millimeters thick and the concrete kept thoroughly wet.
- Subject to the approval of the Engineer, a liquid, membrane-forming curing compound, supplied at the rate recommended by the manufacturer may be used. Curing compounds shall not be used on a surface where bond is required for additional concrete.
- Surfaces of concrete which are protected by formwork which is left in place for five days shall not require any additional curing (except as specified for hot weather). If the formwork is removed in less than five days, the concrete shall receive moist curing as above until five days have elapsed since the concrete was placed.
- No concreting will be allowed until all materials required for the curing phase are on site and ready to use.

Cold Weather Concreting

Special measures over and above those generally described in this Specification shall be taken during concreting in cold weather. Cold weather, for the purpose of the specification, is when the air temperature is at or below 4 °C, or is when, in the opinion of the Engineer, the air temperature is likely to fall below this limit within the next 24 hours.

In these circumstances, concrete must be heated for placing and then protected from the adverse effects of low temperatures.

All concrete that has been placed when the air temperature is 4 °C or below shall be protected and heated as necessary. When, in the opinion of the Engineer, the air temperature is likely to fall below 4 °C at any time during the 24 hours after the concrete is placed, the concrete shall then also be protected and heated, where necessary, from the time the concrete is placed.

When the air temperature falls below 4 °C during the five days after the concrete is placed, the Engineer may instruct the concrete to be protected and heated where necessary, to prevent damage to the concrete by freezing or to allow the concrete to develop sufficient strength to carry the dead and live loads which will be imposed on it by further construction work or general traffic in the near future.

The system of protection, surface or enclosed heating, where necessary (or fully insulated forms) is subject to approval of the Engineer. It must be adequate and designed in relation to ambient conditions and the type of construction to satisfactorily achieve these curing conditions in the concrete.

For proper curing of concrete, the temperature of all surfaces of the concrete shall be maintained at not less than 20 °C for five days, or at not less than 10 °C for seven days after placing. Further, the concrete shall be kept above freezing temperature for a period of at least nine days and shall be kept from alternate freezing and thawing for at least 14 days after placement.

The use of salt or other chemicals in the mix to lower the freezing point or accelerate the

sets is prohibited unless specifically authorized by the Engineer. At no time shall the temperature of the mixed concrete exceed 40 °C.

At the end of the specified protection period, the temperature of the concrete shall be reduced gradually at a rate not exceeding 11 °C per day until the outside air temperature has been reached.

A full record shall be kept of the temperature of concrete upon placing, and a daily record of the curing temperature of the concrete for the full protection period. The records shall be made available to the Engineer upon his request.

Concrete that is allowed to freeze or which obtains insufficient curing conditions, shall be subject to all necessary investigations and testing as deemed necessary by the Engineer. If found unsatisfactory, all such concrete shall be removed and the portion reconstructed as directed by the Engineer.

Heating Materials

When the air temperature is at or below 4 °C, the mix water shall be heated to the temperature not greater than 63 °C which will produce concrete within the specified range at the time of placing.

If the air temperature is, or was, at any time during the previous 24 hours, at 0 °C, or below, or if the stockpiles of coarse and fine aggregate contain frozen material or are snow covered, then the aggregates as well shall be heated to a temperature of not less than 20 °C, nor more than 63 °C. The aggregates shall be uniformly heated in the stockpiles and/or bins by steam, either injected, live or circulated in coils or by using dry heat before the aggregates are placed in the mixer.

Whatever system is used, it shall be designed to give uniform heating that will avoid local overheating which may be injurious to the materials. That part of the stockpile in use shall be protected with tarpaulins, waterproof paper or plastic sheeting against the formation of ice and the accumulation of snow.

No material, including the mix water, shall be at a temperature above 63 °C at the time of mixing. The heated water over 40 °C should not be brought in direct contact with the cement but shall be added into the mixer before, with, or after the aggregate is placed and the mix turned over a few times to distribute the heat before the cement is added; the prescribed mixing time shall then start.

Hot Weather Concreting

Hot weather concreting shall be as per CSA A23.1.

The concrete temperature at the time of placing in hot weather shall not exceed 24 °C. In event of the concrete temperature limit being exceeded the concreting operations shall be suspended until the constituent materials of the concrete are cooled. Aggregate stockpiles may be sprayed with water to give evaporative cooling. The mixed water may be cooled by ice, the ice may be incorporated directly into the concrete as part of the mix water provided it is completely melted by the time the mixing is completed.

Specifically, all slabs shall be covered immediately after the final set with sacking or other similar material which shall be kept continuously moist for at least five days. Subject to approval of the Engineer a liquid membrane-forming curing compound, applied at the rate recommended by the manufacturer, may be used. Curing compounds shall not be used on a surface where bond is required for additional concrete, or where a bonded surface coating

such as paint or tile is to be applied.

At no time during the curing period shall the temperature of the concrete exceed 60 °C, wherever possible, it shall be maintained at the optimum curing temperature of 21 °C.

The use of retarding admixture in hot weather concreting, to facilitate placing finishing and to control temperature rise in the concrete shall be approved by the Engineer prior to use in the works. The amount of retarding admixture added to the concrete shall be a minimum.

Temperature records of concrete placed in hot weather shall be kept together with those of the corresponding air temperature readings. Where required by the Engineer, suitable tube inserts in the concrete for thermometers shall be provided.

In order that curing water may reach formed surfaces, the forms shall be loosened slightly and water shall be poured between the forms and concrete.

403.11.06 Patching of New Concrete

Immediately after removing forms, all concrete surfaces shall be inspected and any poor joints, voids, stone pockets or other defective areas and all tie holes shall at once be patched before the concrete is thoroughly dry. Defective areas shall be chipped away to a depth of not less than 25 mm with the edges perpendicular to the surface.

After the cleaned area has been passed by the Engineer, a grout of "Daraweld-C" shall be prepared by thoroughly premixing one part of cement with two parts of fine mason's sand. In a separate container "Daraweld-C" shall be combined with an equal amount of water, and then added to the consistency of heavy cream. The grout shall be scrubbed onto the surface with a stiff brush or corn broom in a layer not more than 3 mm thick.

While the bonding coat is still soft and plastic, the surface shall be plastered with a cement mortar to which 25% of the mixing water has been replaced with "Daraweld- C". The mortar shall consist of Portland cement and fine aggregate in approved proportions and shall match the colour of the surrounding concrete.

The finish shall match that of the surrounding concrete.

403.11.07 Anchor Bolts and Dowels

Anchor bolts and inserts shall be accurately set at the positions shown and securely held in position by means of wooden templates and wire ties so as to prevent shifting or floating of any metal sleeves during concrete placing. Anchor bolts and dowels shall be set before concrete placement. Anchor bolts and dowels shall not be inserted into placed concrete.

403.11.08 Grouting

Sleeves, handrail posts, equipment bases, and other items shall be grouted as called for on the Drawings. Grout shall be of a non-shrink, non- staining type approved by the Engineer.

Mix grout according to manufacturer's instructions depending on area of usage and placement required. A minimum compressive strength of 45 MPa in 28 days is required with no loads placed on the grout until it has achieved the minimum compressive strength of the surrounding concrete.

403.11.09 Construction Joints

Construction joints shall be made according to approved construction drawings. Before the next pour has commenced, construction joints shall be cleaned and wetted to the satisfaction of the Engineer. All mortar and other foreign material shall be cleaned from the reinforcing steel and forms before concreting is resumed. Construction joints shall be placed in all facings of structures at the end of each pour.

403.11.10 Concrete Finishes

Basic Treatment

Basic treatment to formed surfaces shall be classified as follows:

- Class 1 - Ordinary Surface Finish
- Class 2 - Rubbed Finish

Surfacing and Finishing

All exposed concrete shall be given a Class 1, Ordinary Surface Finish unless otherwise specified.

Class 1 - Ordinary Surface Finish

Immediately following the removal of the forms, all fins and irregular projections shall be removed from all surfaces. On all surfaces, the cavities produced by form ties and all other air voids, honeycomb spots, broken corners or edges and other defects shall be thoroughly cleaned and after having been saturated with water for a period of not less than three hours, shall be carefully pointed and trued with a mortar of cement and fine aggregate mixed in the proportions used in the grade of concrete being finished.

Mortar used in pointing shall not be more than one hour old. The mortar patches shall be cured as specified under CURING. All construction and expansion joints in the completed work shall be left carefully tooled and free of all mortar and concrete. The joint filler shall be left exposed for its full length and with clean and true edges. All patches to match existing texture and colour of the surrounding concrete. The resulting surfaces shall be true and uniform. All surfaces which cannot be repaired satisfactorily shall be "rubbed" as specified for CLASS 2, Rubbed Finish.

Class 2 - Rubbed Finish

After removal of forms the rubbing of concrete shall be started as soon as its condition will permit. Immediately before starting this work, the concrete shall be kept thoroughly saturated with water for a minimum period of three hours. Sufficient time shall have elapsed before the wetting down to allow the mortar used in the pointing of rod holes and defects to thoroughly set.

Surfaces to be finished shall be rubbed with medium coarse carborundum stone using a small amount of mortar on its face. The mortar shall be composed of cement and fine sand mixed in proportions used in the concrete being finished. Rubbing shall be continued until all form marks, projections, and irregularities have been removed, all voids filled and a uniform surface has been obtained.

The paste produced by this rubbing shall be left in place at this time. After all concrete above

the surface being treated has been cast, the final finish shall be obtained by rubbing with a fine carborundum stone and water. This rubbing shall be continued until the entire surface is of a smooth texture and uniform colour. After the final rubbing is completed and the surface has dried, it shall be rubbed with burlap to remove loose powder and shall be left free from all unsound patches, paste, powder and objectionable marks.

403.12.00 CLEAN UP

403.12.01 General

After all sewer mains, manholes and related structures are constructed to the approved construction drawings and specifications, these structures shall be cleaned thoroughly ensuring no foreign material has entered the sewer facility. The sewer facility must be in a broom clean state prior to The City of Calgary taking over ownership of the facility.

403.12.02 Sewer Cleaning

After installation of replacement or new sewers, all newly installed sewers shall be cleaned. The Contractor shall clean the line of obstruction such as solids, roots, sediments, protruding service connections or encrustation to at least 98% of the original capacity so that any subsequent rehabilitation scheme, such as joint grouting or relining, can proceed.

If sewer cleaning or obstacle removal methods cannot remove an obstruction, a point repair excavation shall be made to uncover and remove or repair the obstruction. The City of Calgary's prior approval must be obtained.

Upon completion of the sewer cleaning, clean up and restore externally affected areas to the condition that existed prior to commencement of the work. Remove and haul debris to an approved disposal site.

403.12.03 Temporary Flow Control

For temporary flow control procedure, refer to "**Sewer Bypass Pumping Guidelines**" using the link:

http://www.calgary.ca/PDA/pd/Documents/urban_development/publications/Sewer-Bypass-Pumping-Guidelines.pdf

403.13.00 ACCEPTANCE TESTING

403.13.01 Acceptance Testing - General

After all sewer mains, manholes and related structures have been cleaned in accordance with [403.12.00 Clean Up](#), the system shall be tested to ensure that the sewer is free of defects and that the sewer was installed to the line and grade noted on the construction drawings. Acceptance testing must be carried out for both types of sewer systems and shall include the following:

- Visual inspection of surface features, manholes, and larger sewers.
- Image-based video inspection of the smaller sewers (up to and including **1500 mm** diameter). Pipe larger than **1500 mm** shall be inspected and observations recorded during a walk-through by a Pipeline Assessment & Certification Program (PACP) certified operator or by image-based video inspections where authorized by the

Engineer (subject to obtaining acceptable data quality).

- Deflection testing of PVC sewers in accordance with [403.13.04 Deflection Testing](#) and [403.13.05 Image-Based Sewer Inspection](#).
- The City may request that an Infiltration/Exfiltration test be performed if warranted.
- Pressure testing of forcemains and siphons to the Engineer's satisfaction.

Acceptance testing (including visual inspection, image-based sewer inspection or approved method of digital sidewall scanning, and deflection testing (PVC sewers)) shall be successfully completed prior to issuance of FAC. Testing for FAC shall occur no sooner than one year after installation and backfilling completion. This testing is being implemented in order to better identify and correct defects prior to FAC resulting in a lengthened service life for the infrastructure.

403.13.02 Vertical/Horizontal Alignment Tolerances for Manhole to Manhole Pipe Runs

The horizontal alignment of the facilities will be accepted by the Engineer only if the centre line of 900 mm and smaller diameter pipes shall not be more than 150 mm off the designated alignment. In addition, for pipe greater than 900 mm diameter, the center line shall not be off more than 50 mm per 300 mm of diameter from the designated alignment. For acceptance, where the pipeline alignment is supposed to be straight between manholes, a line of sight through the pipe shall exist from manhole to manhole.

For acceptance the vertical alignment of the sewer main shall not deviate from the designated grade by an amount greater than the total of 6 mm plus 20 mm per meter of diameter of sewer pipe, provided that such variance does not result in level or adverse grade.

For acceptance, no variance from grade vertically or horizontally shall be permitted that results in individual joint deflections in excess of the manufacturer's recommended value to maintain hydrostatic integrity to the limits specified herein.

403.13.03 Infiltration / Exfiltration Limits

The City of Calgary will NOT accept any infiltration/exfiltration (I/E) in sanitary pipes and appurtenances, nor in storm pipes and appurtenances unless they are specifically designed to include that function. Infiltration/Exfiltration (I/E) testing shall be carried out only when there is visible evidence of water entering the pipe or when environmental issues are a concern to the Engineer. For acceptance testing, elastomeric gasket joints for pipe and fittings shall meet the requirements of ASTM D3212, except that the internal hydrostatic pressure shall be 100 kPa (15 psi).

403.13.04 Deflection Testing

Scope

Flexible thermoplastic pipes installed within The City of Calgary which are, or will become, owned by The City of Calgary shall be tested for deflection. The exceptions to this testing requirement are forcemains, service connections on City property, catch basin leads on City property and 150 mm weeping tile collection system (unless testing is specifically requested by the Engineer). Testing on private sites is not required by The City of Calgary and is entirely at the owner's discretion.

Deflection testing shall be carried out to confirm that installed pipes meet the requirements for long-term deflection limits. Deflection testing shall be carried out no sooner than one year after installation and backfilling completion to assess long-term deflection.

In addition to the long-term deflection testing, short-term deflection testing may be performed at the discretion of the developer/contractor no sooner than 30 days after backfill is complete. Short term deflection testing may detect overly deflected pipe prior to surface paving which could result in cost savings to the developer.

Pipe up to 1500 mm diameter shall be inspected by either a Mandrel or by laser profiling. Pipe larger than 1050 mm diameter shall be inspected by either laser profiling or a suitable proving device to confirm that vertical deflection does not exceed either the maximum allowable short (optional) or long term deflection limits stipulated under ***Short and Long Term Deflection Requirements, this section. Deflection testing is to be performed in conjunction with the image-based inspection. After a clear image-based inspection is documented (no mandrels, cables, shackles etc. in front of camera), the mandrel inspection can then be performed.*** The mandrel shall be located in front of, and in clear view of, the television camera. A minimum appropriate distance is 2.5 pipe diameters in front of the television camera.

Note: Regardless of whether short-term testing is performed, where long-term testing indicates failure, (i.e. vertical deflection in excess of 7.5%) the failed pipe section must be excavated and repaired to the satisfaction of Water Services. Maintenance agreements will not be entertained by Water Services in these cases, therefore repair and replacement requires 100% inspection by Water Services during installation and backfill. Image-based sewer inspection and 7.5% mandrel testing or laser profile testing will be required 30 days after backfill is completed.

Inspection Method

All pipe up to and including 1500 mm diameter shall be inspected for deflection by either laser profiling or a “go/no-go” Mandrel device as described herein.

64) Laser profiling may be accepted upon prior approval by the Engineer. Specifications for the proposed system shall be submitted for review, including details on the inspection methodology, final output format, and required software. All required software must be consistent with current City technology. Final reports and supporting material shall be in a format compatible with long-term retention requirements, as stipulated by the City.

- a) The Ovality/Deflection report shall be presented in a continuous graph format with chainage plotted against % ovality. The graph shall include access point numbers and be generated automatically by the Laser Light profiler and software package such as Clearline Profiler or approved equal. Measurements should not require input from the operator.
- b) The digital color video will include a minimum five second calibration bar shot at the start of the uninterrupted video, which should meet the minimum video quality outlined in [403.13.05 Image-Based Sewer Inspection](#) of the Standard Specifications Sewer Construction. The ovality profile should be presented as an Excel plot, CSV or JPEG.

Contractors performing laser profile testing shall employ staff who are suitably qualified and experienced with the equipment and methods required to obtain a quality test.

Laser profile equipment shall be calibrated in accordance with the manufacturer's

recommendations, and evidence of satisfactory calibration shall be confirmed by the Consultant. The calibration results shall be submitted by the Consultant to the Engineer prior to City acceptance of the laser profile results.

The consultant shall ensure all manufacturer's recommendations are followed and shall certify the testing and data processing has been done in accordance with those recommendations. The City reserves the right to have samples of the data independently reviewed, and the Consultant shall provide such software and equipment to the designated reviewer for their use during the review.

At the sole discretion of the Engineer, any suspect sections of pipe, or where the laser profile results are inconclusive due to poor quality images, or due to water or debris in the pipe, shall be tested with a Mandrel. The Mandrel test results shall be accepted as the definitive test.

- 65) Before each usage, Mandrels shall be tested with a Proving Ring certified by Water Resources. The Mandrel or proving device shall be pulled through the pipe in such a manner to ensure that excessive force is not used to advance the device through any deflected portion of the pipe.
- 66) ***Deflection testing is to be performed in conjunction with the image-based inspection. After a clear image-based inspection is documented (no mandrels, cables, shackles etc. in front of camera), the mandrel inspection can then be performed.*** The mandrel shall be located in front of, and in clear view of, the television camera. A minimum appropriate distance is 2.5 pipe diameters in front of the television camera.

Short and Long Term Deflection Requirements

MAXIMUM ALLOWABLE DEFLECTION

<u>Short Term</u>	<u>Long Term</u>
5.0%	7.5%

Short-term deflection, (testing is at the discretion of the developer/ contractor) shall be deemed to be any deflection measured between one month and one year after backfilling.

Long-term deflection shall be deemed to be any deflection measured at least one year after backfilling.

Mandrel Dimensional Requirements

Contractors doing acceptance testing shall provide evidence to the satisfaction of City of Calgary Water Resources that all Mandrels and Proving Rings in use initially meet, and continue to conform, to the dimensional requirements given herein. Proving Rings are required to be certified by Water Resources. Water Resources will maintain a list of all certified rings.

To maintain certification, all certified Proving Rings shall be re-measured annually prior to March 15 of the current year and the data submitted to Water Resources, along with a statement giving the Serial Number and whether the Proving Ring does/does not continue to meet the Specifications.

The mandrel shall be cylindrical in shape, constructed with nine evenly spaced arms and shall generally conform to the following:

The minimum diameter of the circle scribed around the outside of the Mandrel arms shall be

equal to the values indicated on [Drawing 63: Mandrel Design and Sizing](#) for each specific pipe material, within a tolerance of +/- 0.25 mm. The contact length of the Mandrel shall be measured between the points of contact on the Mandrel arm as indicated on [Drawing 63: Mandrel Design and Sizing](#). Prior to each use the outside radius of the Mandrel arms shall be checked for conformance with these specifications with a certified Proving Ring.

Either a dual purpose Go/No Go Proving Ring, sized as noted below, must be used, or two separate Proving Rings, one an 'Oversize Ring' which the mandrel must pass through and the second an 'Undersize Ring' which the mandrel must not pass through.

An Oversized Proving Ring shall be manufactured to a diameter equal to the outside diameter of the Mandrel plus 1 mm. The Proving Ring shall be manufactured to within 0.25 mm of the specified size. The Proving Ring shall be fabricated from 6 mm thick steel minimum. Required Mandrel radii are given on [Drawing 63: Mandrel Design and Sizing](#).

An Undersized Proving Ring shall be manufactured to a diameter between 0.10 and 0.30 mm less than the diameter of a circle that would be scribed by the specified Mandrel size.

The Ring must be stamped with the NAME of the manufacturer or an agreed abbreviation and a unique SERIAL NO. formatted as follows: >CC< >daymonthyear of manufacture< >nominal diameter< >mm< >5.0% or 7.5%< >Ring No. on the day of manufacture< >SW and/or +PW< (for solid wall or profile wall) >Oversize or Undersize< (if not a Go/No Go Ring).

403.13.05 Image-Based Sewer Inspection

Inspection - General

The sewer inspection method is image-based inspection, but The City of Calgary may accept the digital sidewall scanning method on a case by case basis and where authorized by the Engineer (subject to approval of image format and method of data delivery). The following specifications will pertain to image-based inspection hardware, software, and output.

Sewer inspections shall be performed to observe and record structural and service defects and construction features, to assess thoroughness of cleaning, and to verify new installation and rehabilitation work quality prior to acceptance. All observations shall be coded in accordance with the latest version (currently version 6.0) of Pipeline Assessment & Certification Program (PACP) codes, and the findings shall be submitted in an inspection report consisting of a hardcopy data file and the original video recording (***in digital format on portable hard drive or USB flash drive***). Condition coding shall only be performed by operators who have successfully attained PACP certification.

All pipe up to and including 1500 mm diameter shall be inspected with image-based video inspection. Upon approval of the Engineer, the exceptions to this inspection requirement include forcemains, service connections on City property and catch basin leads on City property. Pipes larger than 1500 mm diameter shall be inspected and observations recorded during a walk-through by an operator with PACP certification, or by image-based inspection where authorized by the Engineer (subject to obtaining acceptable data quality).

Equipment

Inspection Unit

The inspection unit shall consist of a self-contained vehicle with separate areas for viewing and equipment storage. Each unit shall be equipped with a cellular telephone and a suitable

communication system linking all crew members. Each inspection unit shall be equipped with fans and blowers to remove any fog, which may be present in the sewer at the time of the inspection.

Inspection Equipment

Inspection equipment shall consist of cameras, lighting, cables, power source, monitor, and digital video recorder (computer system with capture card or dedicated unit), and other related equipment. The camera employed for sewer and manhole inspections shall be a pan-and-tilt type, capable of panning 360° and tilting 270°. The adjustment of focus and iris shall allow optimum picture quality and the focal range shall be adjustable from 100 mm to infinity.

The light source shall be adjustable to allow an even distribution of light around the sewer perimeter without loss of contrast, flare out of picture, or shadowing. Video overlay equipment shall be capable of superimposing alpha numeric information onto the video recording and shall be capable of providing a minimum of 15 lines of information, with 30 characters per line. All digital video recordings shall be submitted on portable hard drive, or USB flash drive. Digital video recordings shall be captured from the live source (digital videos to a hard drive), and later transferred to portable hard drive or USB flash drive for submission. Digital video shall not be captured from video tape recordings.

For sewer inspections, the camera shall be transported through the sewer by means of a rubber tired or crawler tractor. The transport unit must be capable of passing over minor surface imperfections, including (but not limited to) broken joints and solid debris up to 40mm in height. Mounting of the camera on a float or skid for tow through the sewer shall be permitted where authorized by the Engineer. If the camera is towed, the supporting equipment shall not impede the view of the camera and shall be stable to ensure steady and smooth progress.

The camera transport shall permit complete inspection of the sewer from the centre of the start manhole to the centre of the finish manhole. The camera transport and cable shall be capable of inspecting a minimum of 200 m of sewer from a single access point. A remote reading counter shall be used to measure distance traveled from the centre of the start manhole and measurements shall be recorded in meters to the nearest 100 mm.

The camera height shall be adjustable, so as to position the centre of the lens in the centre of circular sewers and two thirds of the vertical dimension above the invert of egg shaped sewers.

Method of Inspection

The Contractor shall provide the locations where the inspections will be performed to the Engineer with a minimum of 24 hours' notice.

Prior to beginning the inspection, the distance between the centres of the start and finish manhole shall be measured on the ground surface using a steel tape. Flow control measures shall be implemented to ensure a minimum of 80% of the height of the sewer is visible for the entire inspection (***with the exception of where a sag exists***). All fog shall be evacuated from the sewer. The camera lens shall be kept clean at all times and the sewer shall be kept clear of fog during the entire inspection.

All sewer inspections shall be conducted in the direction of flow. ***A reverse set up may be permitted where authorized by the Engineer for site specific circumstances such as accessibility, plugged or bypassed mains.*** Inspections shall generally begin with the upstream sewer in the system and proceed downstream in a consecutive manner. Under no circumstances shall the inspection proceed on a length of sewer until that section and all

upstream sewers in the project/contract have been cleaned.

The face of the start manhole shall be clearly visible at the start of the inspection and the inspection shall be performed from the face of the start manhole to the face of the finish manhole. At the start of the inspection, the length of sewer from the face of the manhole to the cable calibration point shall be recorded and the distance reading at the cable calibration point shall be adjusted such that zero is at the face of the start manhole.

During the inspection, automatic distance measurement shall be indicated on the screen and begin to move immediately as the camera moves. The distance measurement shall be accurate from the cable calibration point to the face of the finish manhole. The camera speed shall not exceed 12 meters/minute, or as agreed to by The City of Calgary.

During inspection, the picture shall be in focus from the point of observation to a minimum of 2.5 pipe diameters ahead. ***On the downstream run, no devices (mandrels, cables, shackles etc.) shall be permitted in front of the camera obstructing its forward view.*** The camera shall be stopped for two seconds at major defects and connections, junctions, and major branches. Forward movement shall be stopped when panning and tilting the camera to observe defects and construction features. ***Defects*** shall include but not be limited to deformed sewers, ***exposed aggregates & rebar, cracks and fractures***, holes, displaced joints, ***missing mortar***, obstructions, and open joints. At ***any*** defects, connections, junctions, and major branches the camera shall be positioned in order to provide a perpendicular view.

The intent of this procedure is to permit a more detailed inspection of specific defects or construction features and reduce distortion during pausing of the video recording.

If inspection of an entire sewer cannot be completed due to a collapse, excessive deformation, solid debris buildup, intruding connections, obstructions, or large displaced joints, ***the Engineer shall be immediately advised. The Engineer and contractor shall review and decide to either abandon the inspection or move the equipment to the downstream manhole and attempt an upstream video inspection.***

A new video inspection will be required after any corrective actions are completed such as but not limited to:

- performing solid debris cutting
- removing intruding connections
- modifying the camera setup (position and/or method of transport)
- completion of emergency repairs

All locations where a complete inspection could not be obtained shall be noted in a log and reviewed with the Engineer on a weekly basis. The log shall note the sewer ID number, steel tape measurement, length inspected (up and downstream), length of missing video and the reason the inspection could not be completed.

Where the qualified reviewer observes structural and operational defects as per NASSCO / PACP standard such as but not limited to: clear water infiltration, fracture, crack, hole, sag, collapse, void, deformation during the inspection, the qualified reviewer shall capture an image (photograph, videotape, or digital file).

Captured images shall be turned over to the Engineer in a report format, or if the defect is significant and will result in immediate operational impact, the Engineer is to be notified immediately to determine necessary remediation action. Similarly, if a void is visible or suspected outside of the pipe, the Contractor shall immediately ensure public safety and notify the Engineer.

At the start of the run, the Contractor is to establish the baseflow level as a percentage of the nominal diameter of the sewer. A minimum baseflow of 5% must be established for inspection to proceed. If the minimum base flow exceeds 20% pipe diameter, flow control measures are to be utilized, such as but not limited to; scheduling works for off-peak flow times, plug or limit flow at upstream manholes, and temporary by-pass pumping.

For new underground sewer installations, the operational tolerance for sag acceptance by means of a maintenance penalty agreement shall be limited to sags between 10% to 20% greater than established base flow.

Where the qualified reviewer observes a flow disparity above base flow equal to or greater than 10% at any point of the run, the disparity is to be noted in the report with a percentage depth in 5% increments. Any identified sag equal to or greater than 20% requires re-installation.

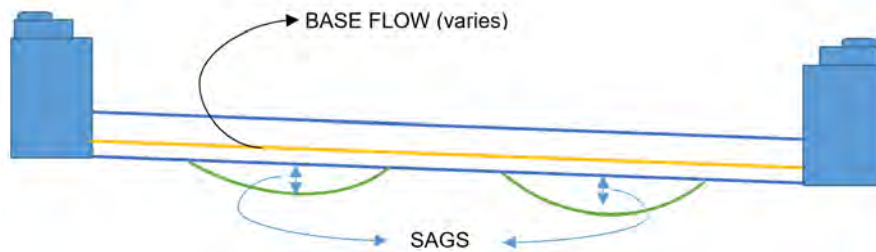

Maintenance Penalty Calculation

The maintenance penalty calculation will be based on the Water Services' estimated frequency of maintenance subject to the number and length of sags within a sewer segment between manholes. The maintenance penalty table is as follows:

SAG (%)	1 SAG ≤ 5m length	2 or More Sags ≤ 5m in total length	Sags >5m in total length
10% ≥ Sag ≤ 15%	6 Yr. Freq.	5 Yr. Freq.	3 Yr. Freq.
15% > Sag < 20%	5 Yr. Freq.	3 Yr. Freq.	2 yr. Freq.
≥ 20%	Dig and Repair	Dig and Repair	Dig and Repair

When agreement cannot be reached with respect to the severity of a sag, a third party video recorded inspection may be requested for verification by the Engineer. The verification shall be performed by means of a calibrated sag gauge mounted in front of the camera, laser profiling or approved equivalent device to measure the depth of a sag.

Sewer Condition Reports

The sewer condition shall be coded in accordance with the latest version (currently version 6.0) of PACP codes. The sewer condition reports shall consist of a hardcopy data file and original video recording (in digital format on portable hard drive or USB flash drive).

Label/Overlay Format

The inspections shall be captured in colour MPEG1 minimum format (HQ VCD standard compliance) from the live video. All digital videos shall be first generation recordings. One complete single digital file shall be submitted for each inspection. The final file may be produced in one of the following three ways:

- Using a computer system and capture card, the original recording must be captured continuously, regardless of the progress of the inspection. Where inspection progress is not continuous, the original raw digital file shall be edited prior to submission to remove the pauses.
- Using a computer system and capture card, the original recording may be captured intermittently, where inspection progress is not continuous. The original raw digital files shall be combined to form one continuous file for submission.
- Specialized video recording equipment which is capable of pausing and resuming live recording may be employed to produce one single file for submission.

All digital video editing shall be done with non-linear video editing software, and in no case shall edited digital files be recompressed. Digital video files shall conform to the following HQ VCD MPEG1 minimum requirements:

- Picture Size: NTSC 352 x 240 @ **30** frames per second
- Default Data/Bit Rate: MPEG 1 @ 1.5 M bits/sec

Video capture equipment shall be capable of capture with no frame loss.

MPEG File Naming Requirements:

<Contract>_<Date>_<Start MH>_<Finish MH>_<Video No>.MPG

Example:

HollyAcres2_2009/10/29_0001-0002, Sec. 15-24-01-5 SW_HA001.MPG

At the start of each inspection, a video overlay system shall be used to clearly display the following alpha-numeric information on the monitor and video recording for 30 seconds. This information shall be entered prior to beginning the inspection:

Example:

Contract HollyAcres2
Date 2009-10-29
Time 21:30
Street Holly Dr. NW

Start MH	0001, sec 15-24-01-5 SW
Finish MH	0002, sec 15-24-01-5 SW
Material	PVC
Size	300
Use	SAN or STORM
Measured Length	110.5
Survey Direction	DOWNSTREAM or UPSTREAM
Video No.	HA001

During the inspection, the following information shall be clearly displayed on the periphery of the screen, on the monitor and video recording. The information shall be arranged to minimize interference with the inspection image:

Bottom Centre	Automatic update of the camera's distance from the centre of the start manhole	Ex. 15.3 m
Top Left	Start MH	Ex. 0001, sec 15-24-01-5 SW
Top Right	Finish MH	Ex. 0002, sec 15-24-01-5 SW

The inspection reports and video recordings shall be labeled with or accompanied by the following information:

Contract	Ex. HollyAcres2
Mains (Start MH - Finish MH)	Ex. 0001-0002, sec 15-24-01-5 SW; 0002-0003, sec 15-24-01-5 SW; 0003-0004, sec 15-24-01-5 SW
Dates Completed	Ex. 2009-10-29 to 2008-11-15

Quality Control

Camera Position

Camera position tolerance shall be +/- 10% of the vertical dimension of the sewer. If the camera position does not satisfy the requirements, the inspection shall be re performed at the Contractor's expense.

Distance Accuracy

Distance measurement within the sewer shall be accurate to within 0.5% of the above ground measurement as confirmed by a steel tape or measuring wheel measurement between faces of the start and finish manholes. If the distance measurement does not satisfy the accuracy requirements, the inspection shall be re performed at the Contractor's expense.

Recording Resolution

Digital MPEG video playback shall provide a minimum of 250 lines of resolution around the periphery of the picture. If requested by the Engineer, resolution shall be confirmed by recording a RETMA type resolution chart as follows:

- Recording shall show the camera and accessories set up for an actual inspection (i.e. video signal routed through the cable reel, video overlay system etc.)
- Recording shall show camera being introduced and reaching its final position for the test
- Resolution chart shall fill the monitor screen
- Resolution chart shall be illuminated evenly and uniformly without reflection and illumination source shall accurately simulate the lighting used in the sewer
- Test shall be recorded for 30 seconds
- Camera shall be identified on the recording
- Test shall be performed at the start of a tape or digital recording

Operator Certification - Inspection

Each inspection unit shall have a minimum of one operator on site at all times who has successfully attained PACP certification. A copy of the operator's PACP certification shall be submitted to the Engineer at least ten business days prior to the commencement of work.

The operator shall be fully trained in all aspects of sewer inspection and shall be capable of making accurate observations and recording all conditions which may be encountered in the sewers.

If no certified operators are available on the given day, no inspection work shall be performed.

Operator Certification - Condition Coding

Condition coding shall be performed by an operator who has successfully attained PACP certification. A copy of the PACP certification for each operator shall be submitted to the Engineer at least ten business days prior to the commencement of work.

Sample Inspection Report

At least two weeks prior to beginning the inspection work, a sample inspection report, video recording, and corresponding hardcopy data file, shall be submitted for review. One submission shall be made for each camera proposed for use on the work; the camera make, model, and serial number shall be clearly identified on each video. The resolution of each camera shall be demonstrated using the recording resolution procedure contained herein. The submission shall satisfy all the specifications contained herein and the accepted report submission will be used as benchmark for subsequent inspection report submissions.

No inspection work shall be performed until an acceptable sample inspection report has been submitted for a camera to be used in the completion of the work.

Coding Accuracy

Coding accuracy shall be a function of the number of defects or construction features not recorded (omissions) and the correctness of the coding and classification recorded.

Coding accuracy shall satisfy the following requirements:

- Header accuracy 95%
- Detail accuracy 85%

The Contractor shall implement a formal coding accuracy verification system at the onset of the work. Coding accuracy shall be verified by the Contractor on a random basis, on a minimum of 10% of the inspection reports or one per video recording, whichever is greater. The coding accuracy checks shall be submitted along with the corresponding video recording.

A minimum of two accuracy verifications shall be performed for each operator for each working week. Coding not satisfying the accuracy requirements shall be returned to the contractor for re coding and the accuracy of the inspection immediately preceding and following the non-compliant inspection shall be verified by the Contractor. This process shall be repeated until the preceding and subsequent inspections meet the accuracy requirements. Any operator failing to meet the accuracy requirements on two occasions shall not be permitted to code on the remainder of the project.

Acceptance of Inspection

Inspection reports, video recordings and hardcopy data files will be reviewed by the Engineer to ensure compliance with the specifications within ten working days of submission. The frequency of review will be adjusted based on the results of the review.

Non-compliant submissions will be returned for correction by the Contractor, at the Contractor's expense. Corrected submissions shall be resubmitted within five working days.

Submission to City

The Engineer shall submit to The City of Calgary the following documents, which must be reviewed prior to submission by a reviewer with PACP certification:

- A declaration letter signed by a certified employee of the consultant stating that they have 'reviewed the Sewer Inspection Report'. In addition, this letter is to include a list of all defects including corrective actions taken.
- Bound hard copies of inspection reports for both sewer mains and manholes.
- Digital video recordings of sewer mains on portable hard drive or USB flash drive.
- Separate electronic data files of sewer main inspection reports on CD-R, DVD, portable hard drive or USB flash drive. The method of data delivery will be either the standard PACP format or The City of Calgary's template.
- A copy of the PACP certification for each operator who carried out the inspection, as well as the name and a copy of the certification of the Consultant's reviewer who certified the submission.

403.13.06 Manhole Inspection

Manholes shall be visually inspected and an inspection report, in a format acceptable to the Engineer, submitted to The City of Calgary along with the other inspection data and documents noted elsewhere in [403.13.00 Acceptance Testing](#).

403.13.07 Pressure Testing Procedure for HDPE Sanitary Sewer Forcemain Pipe

For pressure testing procedure of HDPE sanitary sewer forcemain pipe, please refer to section 504.09.03 of *Standard Specifications Waterworks Construction*.

403.14.00 ABANDONMENT OF SEWER INFRASTRUCTURE

403.14.01 Abandonment of Sewer Infrastructure (Storm and Sanitary)

Abandonment of Sewer Pipe - General

In an effort to minimize the length of abandoned infrastructure connected to existing mains, and to reduce the potential of inflow/infiltration, all abandoned sewers (storm and sanitary) shall be plugged and sealed as close to the existing (live) main as practically possible.

MR and/or R/W

Concrete and PVC pipes 200 mm in diameter or smaller, located on future MR or R/W land may be left in place and deemed abandoned by sealing the lead (pipe) with a manufactured compression/mechanical type plug. Place concrete over top of the plug with low slump cast-in-place concrete.

Pipes larger than 200 mm but smaller than 575 mm in diameter, located on future MR or R/W land, may be left in place and deemed abandoned as follows:

- For concrete pipe, place sandbags and/or bricks 300 mm inside of the lead (pipe) to be

abandoned, and seal with low slump cast-in-place concrete.

- For PVC pipe, place sandbags and/or bricks 300 mm inside of the lead (pipe) to be abandoned. Coat the inner pipe with a layer of approved sewer pipe sealant (see [402.05.04 Connector Sealants](#)) in order to create a watertight barrier. Place concrete over top of sandbag/brick barrier with low slump cast-in-place concrete.

Pipes 575 mm in diameter or larger, located on future MR or R/W land, shall have abandonment methods detailed on drawings. Proposed methods must be approved by Water Resources prior to commencement of any work.

Private Land

All sewer infrastructure (storm and sanitary) located on future private land shall be excavated and removed completely up to the property line. At the property line, sewer infrastructure shall be deemed abandoned provided the procedures above for (MR and/or R/W are followed.

403.14.02 Abandonment of Manholes

Manholes shall be deemed abandoned as follows:

MR and/or R/W

For manholes located on MR or R/W land, plug all leads (pipes) at the manhole as per [403.14.01 Abandonment of Sewer Pipe \(Storm & Sanitary\)](#). Excavate and remove each manhole frame/lid, collar and slab top. Barrels may be left in place or removed to their base.

Fill base with sand and/or clay and compact to meet standards specified in *Standard Specifications: Roads Construction*. Seal the top of the abandoned manhole with low slump cast-in-place concrete.

Private Land

For manholes located on future private land, plug all leads (pipes) from the manhole at the property line as per [403.14.01 Abandonment of Sewer Pipe \(Storm & Sanitary\)](#). Excavate and remove all manholes (including lids, frames, barrels and pipes).

403.14.03 Abandonment of Catch Basins

Catch basins shall be deemed abandoned as follows:

MR and/or R/W

For catch basins located on future MR or R/W land, plug all leads (pipes) to the existing live main as per [403.14.01 Abandonment of Sewer Pipe \(Storm & Sanitary\)](#). Excavate and remove all catch basins and their leads up to the plug.

Note: For special cases where it may not be practical to remove catch basin leads (i.e. existing roadways), written permission and approval by Water Resources must be obtained prior to commencement of any work.

Private Land

For catch basins located on future private land, plug all leads (pipes) at the property line as per [403.14.01 Abandonment of Sewer Pipe \(Storm & Sanitary\)](#). Excavate and remove all

catch basins and their leads completely.

Note: For special cases where it may not be practical to remove catch basin leads (i.e. existing roadways), written permission and approval by Water Resources must be obtained prior to commencement of any work.

403.14.04 Abandonment of Other Storm or Sanitary Infrastructure

For any other storm, or sanitary infrastructure abandonment / decommissioning requirements, please consult with Development Approvals group, Water Resources.

The inspection reports, video recordings and diskettes shall be labeled with the following information:

Contract	Ex. HollyAcres2
Mains (Start MH - Finish MH)	Ex. 0001-0002, sec 15-24-01-5 SW; 0002-0003, sec 15-24-01-5 SW; 0003-0004, sec 15-24-01-5 SW
Dates Completed	Ex. 2009-10-29 to 2008-11-15

403.15.00 BIORETENTION SUBDRAIN SPECIFICATIONS

403.15.01 General

All bio-retention areas shall have **subdrains** below the growing medium to drain excess water to the storm sewer system. **Subdrains** are required unless specifically waived upon request and substantiation of subsurface site conditions providing sufficient infiltration capacity (e.g. saturated hydraulic conductivity in excess of 25 mm/hr). **Refer to Module 2: Bioretention and Swales on the Low Impact Developments page at calgary.ca for more information.**

403.15.02 Materials

Pipe

Subdrains shall be a minimum of **150 mm** diameter perforated PVC pipe. Pipe shall conform to [Section 402.01.01 PVC Pipe](#) of the latest edition of the City of Calgary Sewer Specifications.

Drain Rock

Subdrain shall be surrounded by drain rock as shown on Contract Drawings. Drain rock shall be washed, graded, crushed durable rock conforming to the following gradations:

Sieve Designation	Percent Passing
25.0 mm	100
19.0 mm	0 - 100
9.5 mm	0 - 5
4.75 mm	0

Rock must be transported and handled so that it remains clean, with a minimum of dirt or fines, throughout installation.

Observation/Clean Out Port

Observation ports shall be provided as noted in [403.15.03 Execution – Observation Port](#), and shall be one of the following:

- Solid wall PVC pipe with a diameter equal to the **subdrain** pipe **as shown in Sheet 66**. Pipe shall conform to [Section 402.01.01 PVC Pipe](#) of the latest edition of the City of Calgary Sewer Specifications.
- A catch basin conforming to Sections [402.01.06](#) and [402.07.01](#) of the latest edition of the City of Calgary Sewer Specifications.
- A manhole conforming to Sections [402.01.05](#) and [402.06.01](#) of the latest edition of the City of Calgary Sewer Specifications.

Filter Fabric

Filter fabric shall be Amoco 4545 non-woven geotextile fabric by Nilex, or equivalent as approved by a qualified engineer; **subject to approval by Water Resources**. It shall be delivered, stored and installed in accordance with the manufacturer's instructions.

Granular Filter Material

Sand for the Granular Filter Layer shall be clean sand with a maximum particle size of **3** mm.

Pea Gravel for the Granular Filter Layer shall be **7-10** mm diameter clean, washed uniform material. Materials for the granular filter must be transported and handled with care and kept clean and separate prior to and during installation.

403.15.03 Installation / Execution

Pipe

Subdrain pipe shall be installed along the length of the rock-filled trench below the bio-retention area growing medium as shown on the approved drawings. **Subdrain** pipe shall run the full length of the bio-retention area and connect to an approved drain outlet. The drain outlet shall be backfilled with a "**groundwater** plug" to the underside of the growing media to prevent water in the drain gravel from leaking out of the bio-retention drain gravel.

Drain outlets can include a catch basin, manhole or service connection pipe, or other approved outlet.

Pipe shall be installed with "holes down" and "printing up".

Maximum run of **subdrain** pipes between observation ports is 30 m with "one way" access, and 60 m with "two way" access for pipe up to 150 mm in diameter. For 200 mm diameter and larger **subdrain** pipe, observation ports must be either a catch basin or a manhole, and spacing cannot exceed **130** m.

Pipes shall be laid in straight sections between observation ports, but may curve to the minimum permitted radius as per manufacturers' recommendations where shown on approved plans.

Connections to the storm sewer system shall be able to accommodate a sewer inspection camera and shall be:

- Straight connections to pipe at least 200 mm diameter; OR
- Connections to manholes or, where permitted, catch basins

Connections to the storm sewer system must conform to the City of Calgary Sewer Specifications.

Perforated Pipe shall be laid flat (or parallel to the slope of the bio-retention facility) to encourage maximum water retention in the drain rock. Solid wall pipe shall conform to City of Calgary sewer specifications (latest edition).

Terminal end of pipe shall be closed with an observation port.

Pipe shall be laid in a trench filled and/or backfilled with drain rock and:

- Pipe shall be laid at the top of the rock trench, immediately below the filter fabric or granular filter, if the bio-retention area is designed to infiltrate water into the subsurface; OR
- Pipe shall be laid in the bottom of the rock trench if the bio-retention area is not designed for infiltration (may be lined or limited by subsurface infiltration capacity)

Source Control Practices must be maintained in a clean condition to permit infiltration and water storage. No deleterious materials of any kind are allowed to enter the gravel/rock or the **subdrain** pipe. Extreme care must be taken during construction to prevent any water, mud or other material from entering the construction site.

Observation/Clean Out Port

Observation ports can be any of the following:

- PVC riser pipe to the surface with a long radius bend connection to the **subdrain** pipe to permit passage of a video camera. The riser pipe shall terminate above the ground surface to prevent entry of water or debris when open, and shall be fitted with a water-tight removable cap, OR
- Catch basin (protected to prevent entry of debris and sediment), OR
- Manhole (protected to prevent entry of debris and sediment)

The observation ports shall be tested with standard video camera equipment following installation to verify that the video equipment can satisfactorily traverse the length of **subdrain** pipe.

Drain Rock

Drain rock in rock trench for a **subdrain** shall be a minimum of 400 mm deep **or as shown in Sheet 66** and shall fill the width of the trench.

Drain rock shall be either:

- Wrapped with filter fabric to prevent migration of fines into the rock and clogging of the rock voids. If the rock trench is large and the terrain flat such that migration of fines into the rock is expected to be minimal, the filter fabric requirement may be waived for the

- sides and bottom of the trench only with the approval of a qualified engineer OR
- Covered with a granular filter layer that fully covers the top surface of the rock.

Filter Fabric

Filter fabric is not recommended on top of sand filters or as separation layers but recommended on the sides of the trench.

Ends of filter fabric shall be overlapped a minimum of **500** mm.

Granular Filter Layer

The Granular Filter Layer shall be 200 mm thick and composed of:

- 100 mm of pea gravel over the drain rock AND
- 100 mm of clean sand over the layer of pea gravel

The granular filter layer must be carefully installed to keep the materials clean, separate and in even layers.

Acceptance/Video Examination

Completed **subdrain** pipe installations shall be examined by means of a video camera introduced through observation ports. Observation ports must be completed and in their final configuration. Any difficulty or inability to video the entire extent of pipe installation shall be corrected prior to acceptance of the installation.

Any evidence of damage to the pipe observed by video shall be exposed and physically checked and repaired.

Any evidence of debris, sediment or other deleterious material in the pipe may indicate unacceptable material has been introduced into the Source Control Practice. When directed to do so, the areas where this material is observed shall be exposed and physically examined. Removal and replacement of contaminated gravel/rock may be required and shall be done to the satisfaction of the City of Calgary.

LIST OF STANDARD DRAWINGS

DRAWING 1: STANDARD WASTEWATER MANHOLE COVER	126
DRAWING 1A: STANDARD STORM MANHOLE COVER.....	127
DRAWING 1B: MAXIMUM ACCESS FRAME AND MANHOLE COVER	128
DRAWING 1C: MANHOLE FRAME LOCKING COVER	129
DRAWING 2: GRATED MANHOLE COVER	130
DRAWING 3: MANHOLE FRAME RISER.....	131
DRAWING 4: STANDARD MANHOLE FRAME	132
DRAWING 4A: 90 mm SHALLOW MANHOLE FRAME	133
DRAWING 5: 150 mm SHALLOW MANHOLE FRAME	134
DRAWING 5A: MANHOLE FRAME SAFETY GRATING	135
DRAWING 6: PRECAST MANHOLE COLLAR.....	136
DRAWING 7: MANHOLE SLAB TOP	137
DRAWING 7A: SLAB TOP DETAIL FOR SPIGOT-UP INSTALLATIONS.....	138
DRAWING 8: MANHOLE RISERS (BARRELS).....	139
DRAWING 8A: MANHOLE RISERS (BARRELS) SPIGOT-UP INSTALLATION	140
DRAWING 8B: MANHOLE ADAPTORS SPIGOT-UP/BELL-BELL	141
DRAWING 9: MANHOLE STEPS	142
DRAWING 10: PRECAST MANHOLE BASE TYPE 5 'A'.....	143
DRAWING 10A: PRECAST MANHOLE BASE TYPE 5 'A' FOR SPIGOT-UP INSTALLATIONS.....	144
DRAWING 11: PRECAST OCTAGONAL MANHOLE BASE TYPE 5 'A'	145
DRAWING 12: T-RISER MANHOLE	146
DRAWING 12A: 1050 T-RISER MANHOLE	147
DRAWING 13: FIELD CAST MANHOLE BASE TYPE 5 'A'	148
DRAWING 14: EXTERIOR DROP MANHOLE	149
DRAWING 15: TYPE 5 'A' INTERIOR DROP MANHOLE.....	150
DRAWING 16: STANDARD 5 'A' MANHOLE FOR BOX CONDUIT (DUCT)	151
DRAWING 17: CAST-IN PLACE STANDARD TYPE '1' MANHOLE	152
DRAWING 18: PRECAST TYPE '1-S' MANHOLE & ASSEMBLY	153
DRAWING 18A: LARGE DIAMETER MANHOLES 1500 & 1800.....	154
DRAWING 18B: MAX. CONCRETE PIPE PROTRUSION FOR ROUND MANHOLES	155
DRAWING 18C: MAXIMUM CONCRETE PIPE SIZES IN ROUND MANHOLES	156
DRAWING 19: CONTROL MANHOLE (TEST MANHOLE).....	157
DRAWING 19A: SAMPLING CHAMBER	158
DRAWING 19B: PRECAST BASE FOR SAMPLING CHAMBER	159
DRAWING 19C: SLAB TOP FOR SAMPLING CHAMBER	160
DRAWING 20: SKIMMING MANHOLE BASE	161
DRAWING 21: CATCH BASIN SIDE INLET TYPE 'C'.....	162
DRAWING 21A: TWO PIECE CATCH BASIN SIDE INLET TYPE 'C'	163
DRAWING 22: CATCH BASIN GRATE TYPE 'C'	164
DRAWING 23: CATCH BASIN GRATE TYPE 'K-2'	165
DRAWING 24: CATCH BASIN FRAME TYPE 'C'	166
DRAWING 25: CATCH BASIN FRAME TYPE 'K-2'	167

DRAWING 26: PRECAST TOP FOR TYPE 'C' CATCH BASIN	168
DRAWING 27: ALTERNATE PRECAST TOP FOR TYPE 'C' CATCH BASIN	169
DRAWING 28: PRECAST SLAB TOP FOR TYPE 'K-2' CATCH BASIN	170
DRAWING 29: PRECAST SLAB TOP FOR TYPE 'K-3' CATCH BASIN	171
DRAWING 29A: CONCRETE CB COLLAR FOR 'K-3' CATCH BASIN	172
DRAWING 30: PRECAST COLLAR FOR TYPE 'K-2' CATCH BASIN	173
DRAWING 30A: PRECAST FILLER PIECE (CIRCULAR) FOR TYPE 'K-2' CATCH BASIN	174
DRAWING 31: CATCH BASIN PRECAST BARREL	175
DRAWING 31A: PRECAST MONOLITHIC CATCH BASIN BASE	176
DRAWING 32: STANDARD DRAINAGE SWALE EASEMENT CROSSING	177
DRAWING 32A: DELETED	178
DRAWING 32B: DELETED	178
DRAWING 32C: SWALE DETAIL HIGH-BACK AND OVERLAND ESCAPE ROUTE	179
DRAWING 33: BEDDING AND BACKFILL DETAILS FOR RIGID PIPE.....	180
DRAWING 33A: BEDDING AND BACKFILL DETAILS FOR PRECAST CONCRETE BOX CONDUIT PIPE	181
DRAWING 33B: BEDDING AND BACKFILL DETAILS FOR FLEXIBLE PIPE	182
DRAWING 34: TYPICAL RESIDENTIAL SERVICE INSTALLATION	183
DRAWING 35: SEWER SERVICE CONNECTIONS TO MAINS	184
DRAWING 35A: PE PIPE BURSTING (SAN SERVICE REPL) 12" LONG COUPLING	185
DRAWING 35B: PE PIPE BURSTING (SAN SERVICE REPL) 4" LONG TRANSITION COUPLING	186
DRAWING 36: STANDARD BACKFILLING FOR SERVICES	187
DRAWING 37: SERVICE CONNECTION DETAILS FOR SEWER MANHOLE IN CUL-DE- SAC.....	188
DRAWING 38: MANHOLE ASSEMBLY.....	189
DRAWING 38A: MANHOLE ASSEMBLY FOR SPIGOT-UP INSTALLATIONS	190
DRAWING 38B: 5A MANHOLE ASSEMBLY FOR SPIGOT-UP INSTALLATIONS.....	191
DRAWING 38C: NEW 5'A' MANHOLE ON EXISTING SEWER	192
DRAWING 39: BENCHING STANDARDS FOR SEWER MANHOLES	193
DRAWING 40: STORM CATCH BASIN TYPE 'C' ASSEMBLY	194
DRAWING 41: TWIN STORM CATCH BASINS TYPE 'C' ASSEMBLY.....	195
DRAWING 42: STORM CATCH BASIN TYPE K-2 ASSEMBLY.....	196
DRAWING 43: STORM CATCH BASIN TYPE K-3 ASSEMBLY.....	197
DRAWING 43A: STANDARD CATCH BASIN BARREL INSTALLATION DETAIL.....	198
DRAWING 43A-2: CATCH BASIN ASSEMBLY WITH SUMP	199
DRAWING 43B: CATCH BASIN INLET CONTROL ASSEMBLY FOR PLATE TYPE CONTROL	200
DRAWING 43B-2: DEEP SUMP CATCH BASIN INLET CONTROL RETAINING BRACKETS	201
DRAWING 43C: STANDARD CONNECTION OF ROAD SUB-DRAIN TO CATCH BASIN BARREL	202
DRAWING 43D: STANDARD CONNECTION OF ROAD SUB-DRAIN TO STORM MANHOLE BARREL	203
DRAWING 44: TYPE 'C' CATCH BASIN IN 250 GUTTER	204
DRAWING 45: TYPE 'C' CATCH BASIN IN 500 GUTTER	205

DRAWING 45A: TYPE 'C' CATCH BASIN IN A CONCRETE DRAINAGE SWALE	206
DRAWING 46: STANDARD TYPE 'C' LANE CATCH BASIN	207
DRAWING 47: STANDARD TYPE 'C' CATCH BASIN IN HIGHWAY SWALES OR DITCHES	208
DRAWING 48: TYPE 'C' CATCH BASIN IN LOW PROFILE ROLLED CURB WITH 250 GUTTER.....	209
DRAWING 49: TYPE 'C' CATCH BASIN IN LOW PROFILE ROLLED CURB WITH 500 GUTTER.....	210
DRAWING 50: STANDARD TYPE 'C' TWIN CATCH BASIN IN HIGHWAY SWALES OR DITCHES.....	211
DRAWING 51: TYPE 'K-2' CATCH BASIN IN LOW PROFILE ROLLED CURB WITH 250 GUTTER.....	212
DRAWING 52: TYPE 'K-2' CATCH BASIN IN LOW PROFILE ROLLED CURB WITH 500 GUTTER.....	213
DRAWING 53: TYPICAL CATCH BASIN INSTALLATION IN 9.00 m DISHED LANE	214
DRAWING 53A: STORM K-3 CATCH BASIN AND DRYWELL DETAIL FOR PRIVATE USE	215
DRAWING 54: ALBERTA SURVEY CONTROL MONUMENT PROTECTION STANDARD	216
DRAWING 55: LEGAL SURVEY CONTROL TYPICAL SIDEWALK MANHOLE INSTALLATION	217
DRAWING 56: LEGAL SURVEY CONTROL TYPICAL ROADWAY MANHOLE INSTALLATION	218
DRAWING 57: STORMWATER STORAGE SITE SIGN 100	219
DRAWINGS 57A & 57B: DELETED	220
DRAWING 57C: STORMWATER STORAGE SITE SIGN 400	221
DRAWING 58: PIPE SUPPORT AT UTILITY CROSSING.....	222
DRAWING 59: GROUND WATER PLUGS AND WEEPING HOLES AT STORM MANHOLES	223
DRAWING 60: ENCASEMENT PIPE DETAIL	224
DRAWING 61: PORTABLE OR FREESTANDING CONSTRUCTION SIGN	225
DRAWING 62: OUTLET CONTROL STRUCTUREDRAWING 63: MANDREL DESIGN AND SIZING	226
DRAWING 63: MANDREL DESIGN AND SIZING	227
DRAWING 64: SHALLOW BURY STORM INSULATION	228
DRAWING 65: PRECAST CONCRETE BOX JOINT TREATMENT GUIDELINES.....	229
DRAWING 66: SUBDRAIN/CLEANOUT FOR BIORETENTION AREAS/SWALES	230
DRAWING 67: CONCRETE PIPE TO MANHOLE CONNECTION	231



TOP VIEW

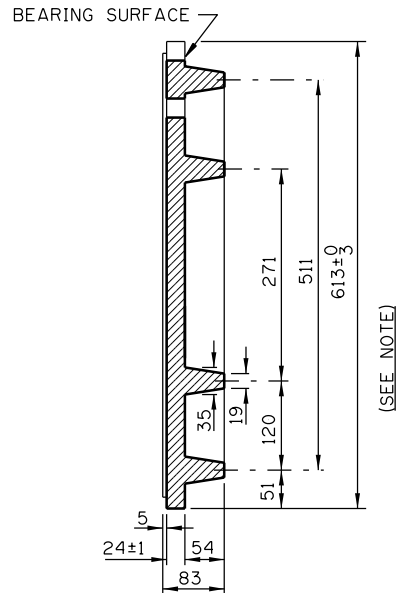

SECTION 'A-A'

(SEE NOTE)

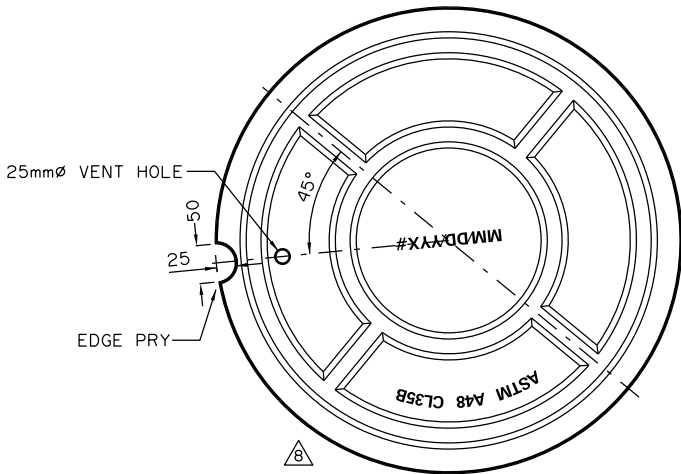

BOTTOM VIEW

NOTE:

FOR SANITARY MANHOLES (8.0m OR DEEPER). REFER TO 402.06.01

MATERIAL SPECIFICATIONS:

1. GREY CAST IRON TO CONFORM TO CLASS 35B A.S.T.M A48 (LATEST EDITION).
2. BEARING SURFACE SHALL BE GROUND OR MACHINED TO PREVENT ROCKING.
3. NOMINAL MASS = 72 KILOGRAMS ±5%.
4. COATED CASTINGS ACCEPTED ONLY WHEN REQUIRED BY CITY.

DIMENSIONS ARE IN MILLIMETRES UNLESS OTHERWISE NOTED

No.	Date	Revision	App'd

Date
2020/01/13

Scale
N.T.S.

Approved by
M. Chapman

for The City of Calgary

SEWER CONSTRUCTION

**STANDARD WASTEWATER
MANHOLE COVER**

Sheet
1

File Number
452.1001.012



TOP VIEW

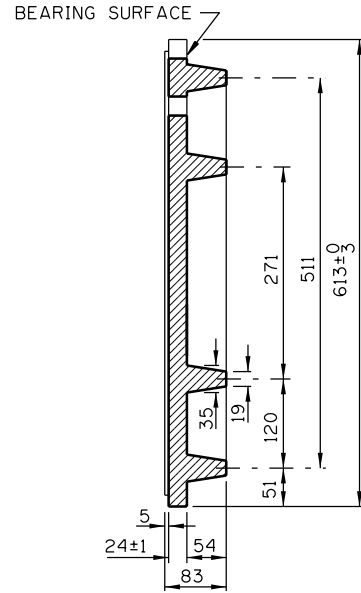

SECTION 'A-A'

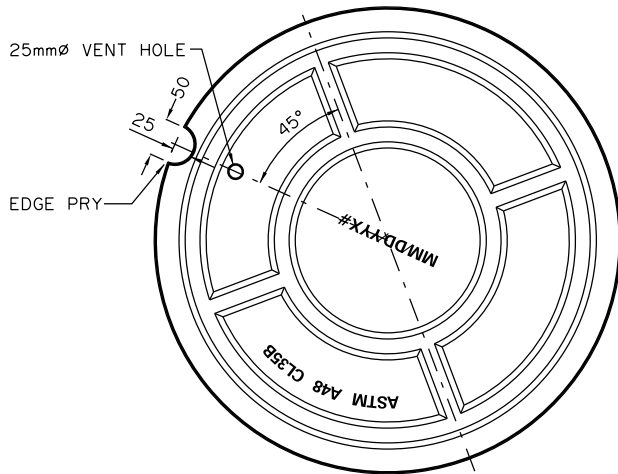

BOTTOM VIEW

NOTE:

MANHOLE SEALS ARE ALSO REQUIRED ON WEeping TILE MANHOLES LOCATED IN TRAP LOWS FOR DESIGNS THAT EMPLOY THE THREE PIPE SYSTEM.

MATERIAL SPECIFICATIONS:

1. GREY CAST IRON TO CONFORM TO CLASS 35B A.S.T.M A48 (LATEST EDITION).
2. BEARING SURFACE SHALL BE GROUND OR MACHINED TO PREVENT ROCKING.
3. NOMINAL MASS = 72 KILOGRAMS ±5%
4. COATED CASTINGS ACCEPTED ONLY WHEN REQUIRED BY CITY.

DIMENSIONS ARE IN MILLIMETRES UNLESS OTHERWISE NOTED

No.	Date	Revision	App'd

Date
2020/01/13

Scale
N.T.S

Approved by
M. Chapman
for The City of Calgary



SEWER CONSTRUCTION

**STANDARD STORM
MANHOLE COVER**

Sheet
1A

File Number
452.1001.038

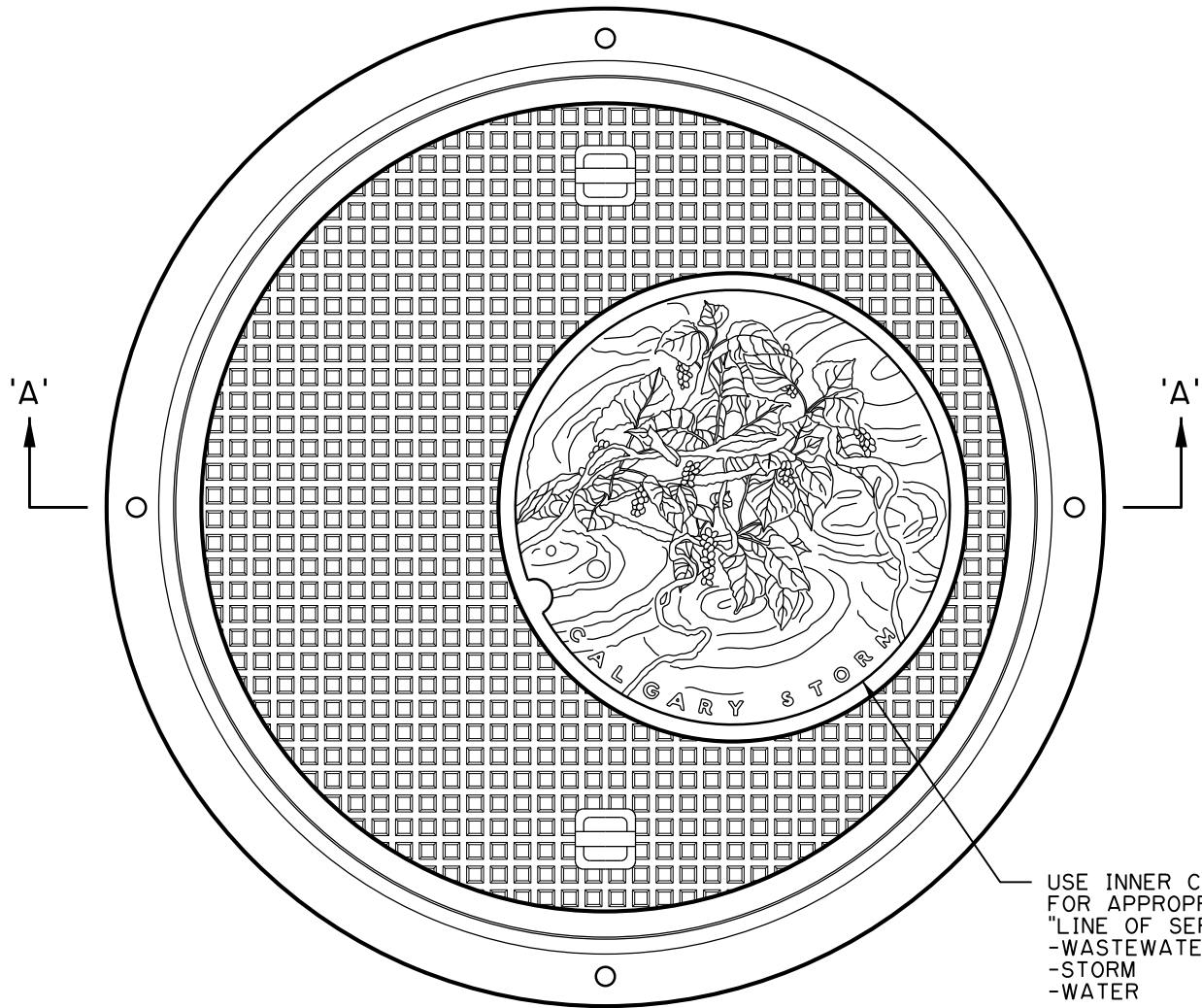

USE INNER COVER
FOR APPROPRIATE
"LINE OF SERVICE"
- WASTEWATER
- STORM
- WATER

PLAN

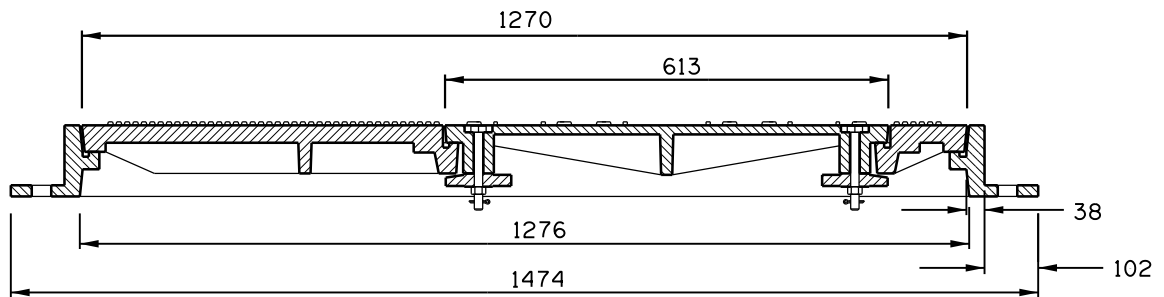

SECTION 'A-A'

DIMENSIONS ARE IN MILLIMETRES
UNLESS OTHERWISE NOTED

No.	Date	Revision	App'd

Date
2020/01/13
Scale
N.T.S.
Approved by
M. Chapman
for The City of Calgary

SEWER CONSTRUCTION
MAXIMUM ACCESS
FRAME AND CITY OF CALGARY
MANHOLE COVER

Sheet
1B
File Number
452.2001.001

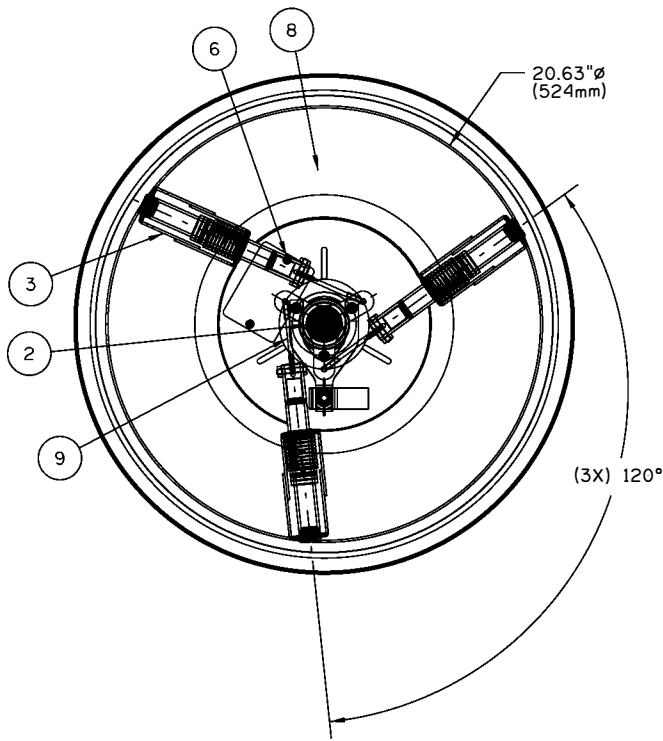

PISTONS RETRACTED

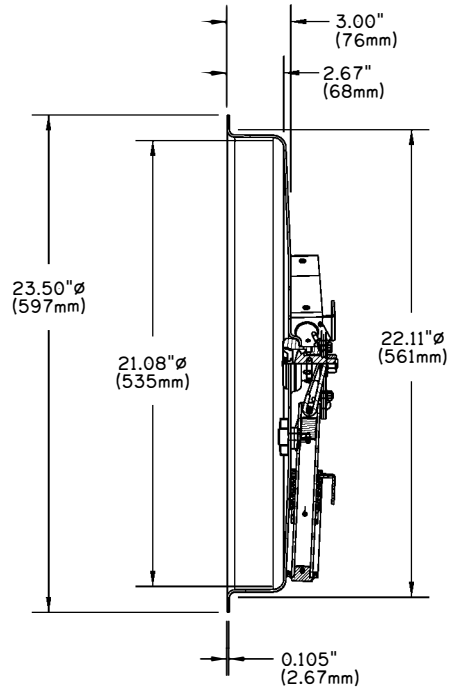

SECTION

NOTE:

TO BE INSTALLED BY CITY OF CALGARY WATER SERVICES STAFF ONLY OR WITH APPROVAL FROM THE MANAGER OF PUBLIC RESPONSE (WATER SERVICES).

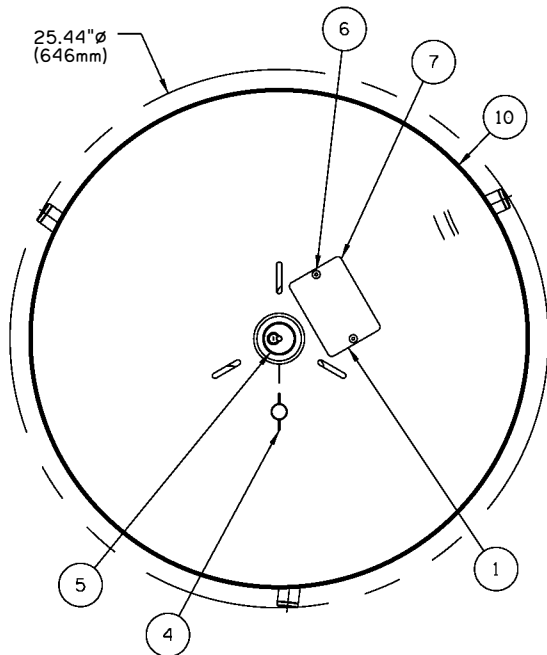

PISTONS EXTENDED

NO.	QTY.	PART No.	TITLE
1	1	141118	DURASHIELD ID / SERIAL TAG
2	1	141120	CENTER SECTION ASSY, DURASHIELD
3	3	141122	CARTRIDGE ASSEMBLY, 2.5" STROKE
4	1	142119	SHIPPING BRACKET, 3/8"-16
5	1	142163	DUST CAP, 2 SEALS, DURASHIELD
6	5	142195	POP RIVET: 3/16" DIA x 1/4" LG
7	1	142199	SERIAL TAG SPACER PLATE
8	1	1421AS221	SKID PLATE, 22.1" STD CLEAR
9	3	1421WF0373	HARDENED WIRE FORM
10	1	14SP2210	DS 22.1" CLEAR PAN, SPUN/WELDED, 23.50" TRIM

NOTES:

- ALL REFERENCED DIMENSIONS ARE APPROXIMATELY WITHIN 0.50" (12.7mm).
- SUPPLIED AND INSTALLED BY CITY OF CALGARY FIELD SERVICES ONLY.

DIMENSIONS ARE IN MILLIMETRES UNLESS OTHERWISE NOTED

No.	Date	Revision

Date
2020/01/13
Scale
N.T.S.
Approved by
[Signature]
for The City of Calgary

SEWER CONSTRUCTION
**MANHOLE FRAME
LOCKING COVER**

Sheet
1C
File Number
452.2004.001

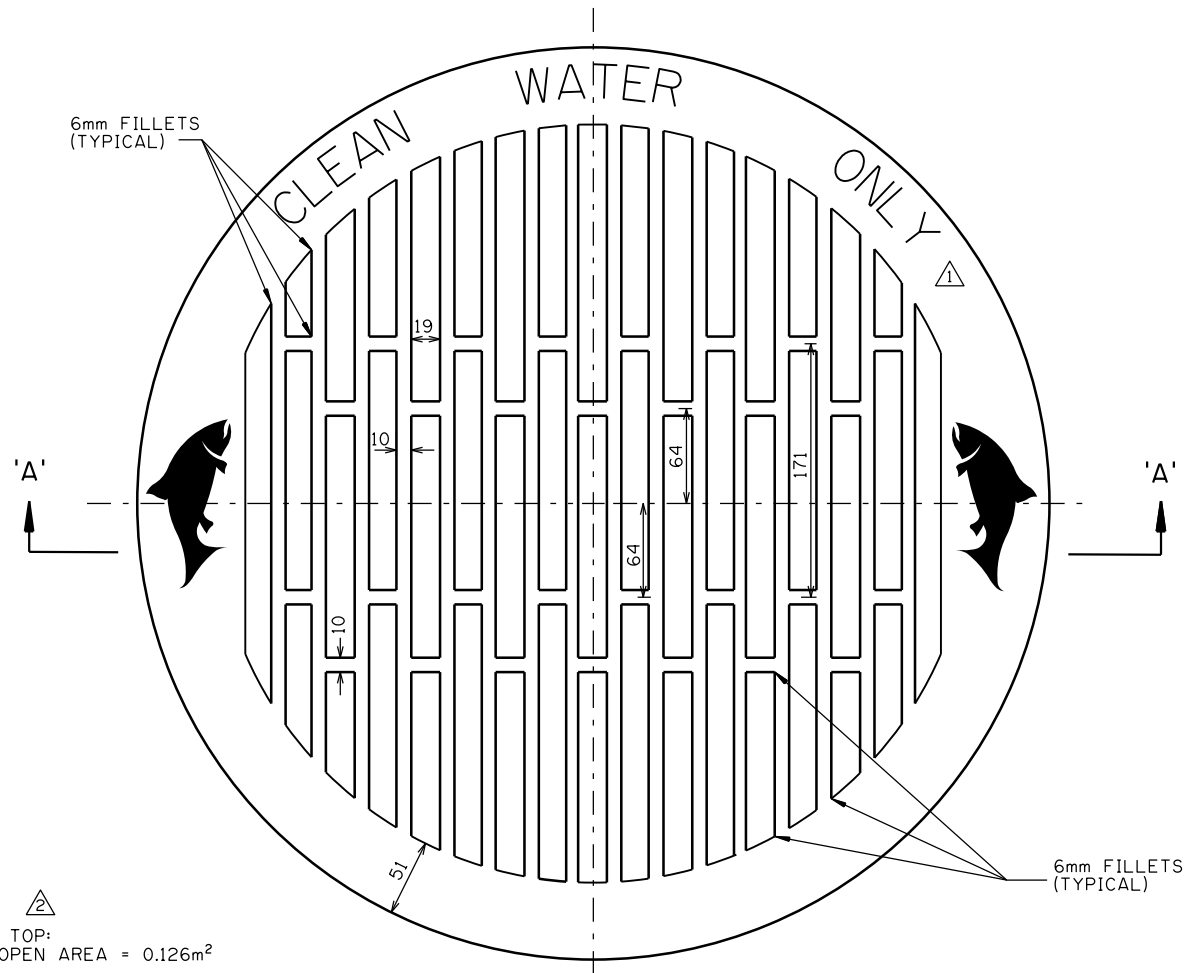

△
 GRATED TOP:
 GRATE OPEN AREA = 0.126m²

ASSEMBLY:
 1. GT - ONE TYPE "GT" GRATE

PLAN

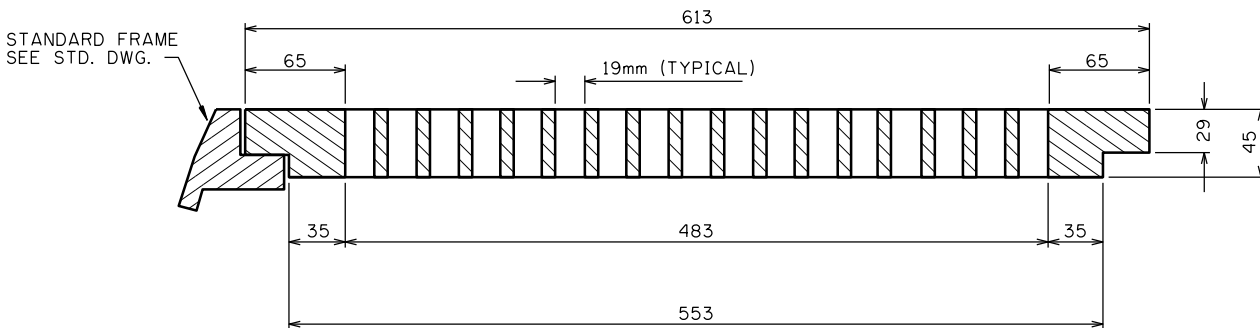

SECTION 'A-A'

MATERIAL SPECIFICATIONS:

- DUCTILE IRON TO CONFORM TO A.S.T.M. A536 (LATEST EDITION) GRADE 80-55-06. △
- BEARING SURFACE SHALL BE GROUND OR MACHINED TO PREVENT ROCKING.
- NOMINAL MASS = 48 KILOGRAMS ±5%.

△△ - COATED CASTINGS ACCEPTED ONLY WHEN REQUIRED BY CITY

DIMENSIONS ARE IN MILLIMETRES
 UNLESS OTHERWISE NOTED

No.	Date	Revision
4	2018/02/15	REVISED NOTES
3	2014/02/01	ASPHALT VARNISH COATING
2	2004/10/01	AREA AND ASSEMBLY NOTES ADDED
1	2003/04/01	ADD CLEAN WATER ONLY TEXT & FISH

Date
1999/09/14

Scale
N.T.S

Approved by
[Signature]

App'd for The City of Calgary

SEWER CONSTRUCTION

GRATED MANHOLE COVER

Sheet
2

File Number
452.1001.011

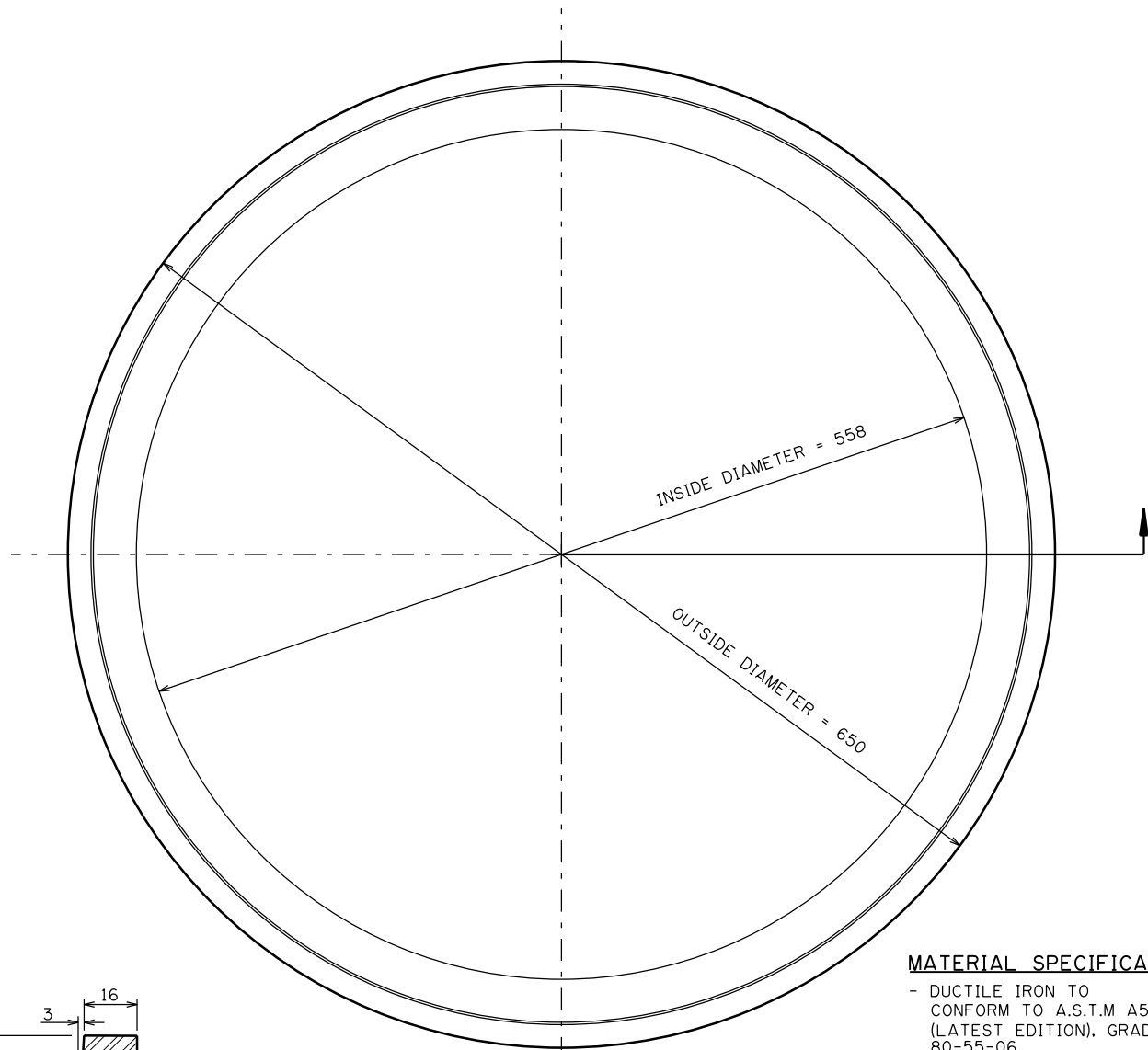

PLAN

MATERIAL SPECIFICATIONS:

- DUCTILE IRON TO CONFORM TO A.S.T.M A536 (LATEST EDITION), GRADE 80-55-06
- BEARING SURFACES SHALL BE MACHINED TO PREVENT ROCKING
- COATED CASTINGS ACCEPTED ONLY WHEN REQUIRED BY CITY

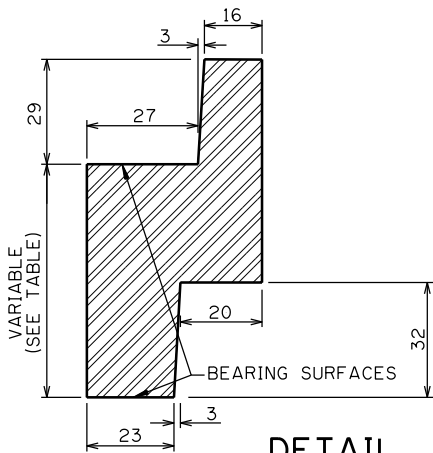

DETAIL

TABLE

TYPE	DIMENSION
A	38
B	51
C	64
D	76

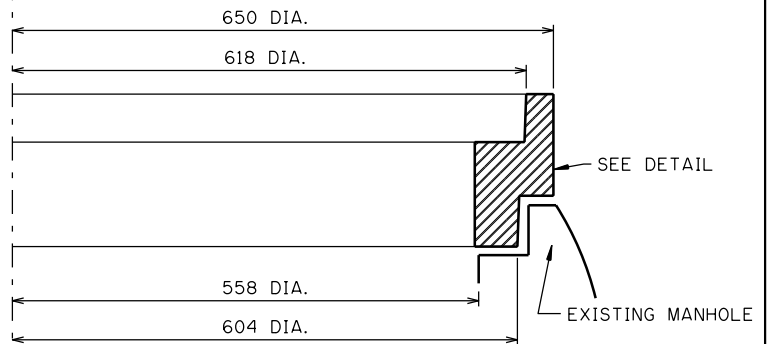

HALF SECTION

DIMENSIONS ARE IN MILLIMETRES UNLESS OTHERWISE NOTED

No.	Date	Revision
3	2018/02/15	REVISED NOTES
2	2014/02/05	ASPHALT VARNISH NOTE
1	2007/04/10	MATERIAL CHANGED TO DUCTILE IRON, REMOVAL OF OUTER RING

Date
1999/09/14

Scale
N.T.S.

Approved by
[Signature]

for The City of Calgary

SEWER CONSTRUCTION

**MANHOLE FRAME RISER
FOR CROWN SURFACE
PAVEMENT ADJUSTMENT**

Sheet
3

File Number
452.1001.007

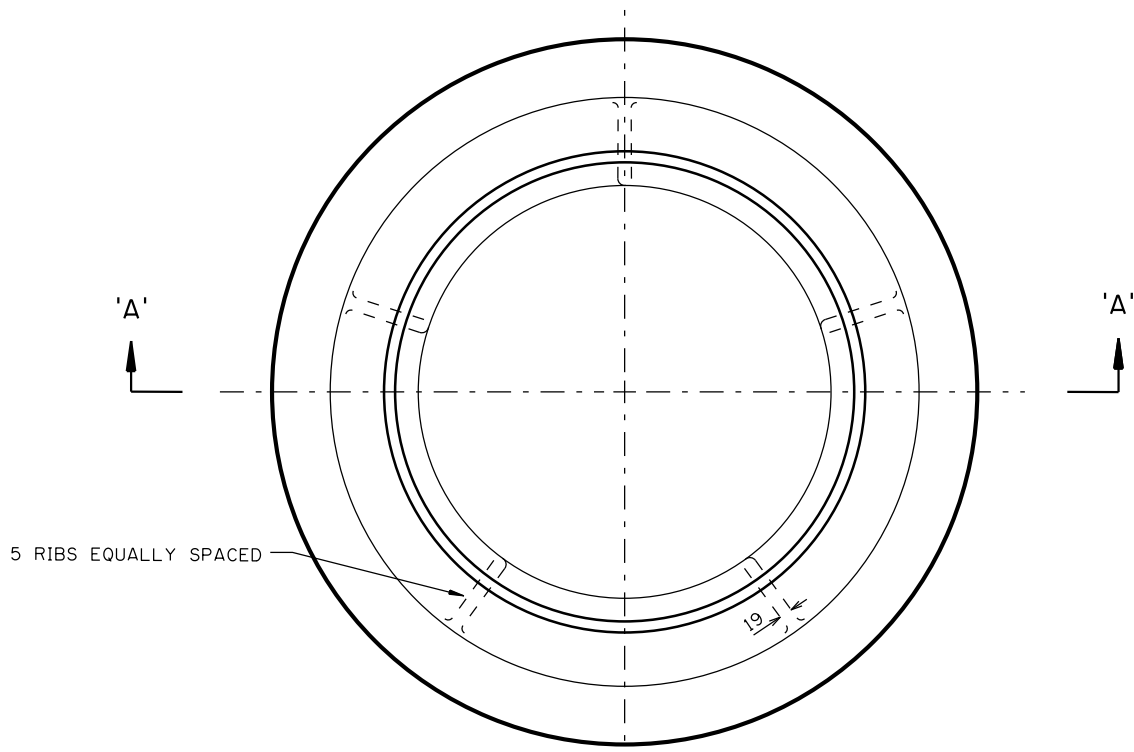

PLAN

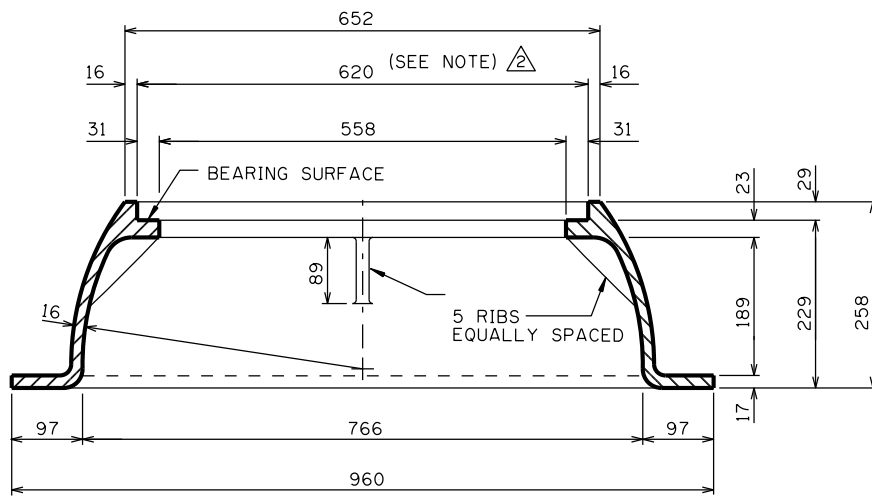

SECTION 'A-A'

MATERIAL SPECIFICATIONS:

- GREY CAST IRON TO CONFORM TO A.S.T.M A48 (LATEST EDITION), CLASS 35B.
- BEARING SURFACE SHALL BE GROUND OR MACHINED TO PREVENT ROCKING
- NOMINAL MASS = 122 KILOGRAMS ±5%
- COATED CASTINGS ACCEPTED ONLY WHEN REQUIRED BY CITY

NOTE:

FOR SANITARY MANHOLES (8.0m OR DEEPER), LID AND COVER SHALL BE AS PER STANDARD DRAWING SHEET #1B

DIMENSIONS ARE IN MILLIMETRES UNLESS OTHERWISE NOTED

				Date 1999/09/14		SEWER CONSTRUCTION	Sheet 4
				Scale N.T.S			STANDARD MANHOLE FRAME
4	2020/02/07	REVISED NOTES	M.C.	Approved by			
3	2018/02/15	REVISED NOTES	M.C.	for The City of Calgary			
2	2015/12/08	NOTE FOR DEEP (SANITARY) MH FRAME	M.C.				
1	2014/02/01	ASPHALT VARNISH COATING					
No.	Date	Revision	App'd				

8 RIBS EQUALLY SPACED

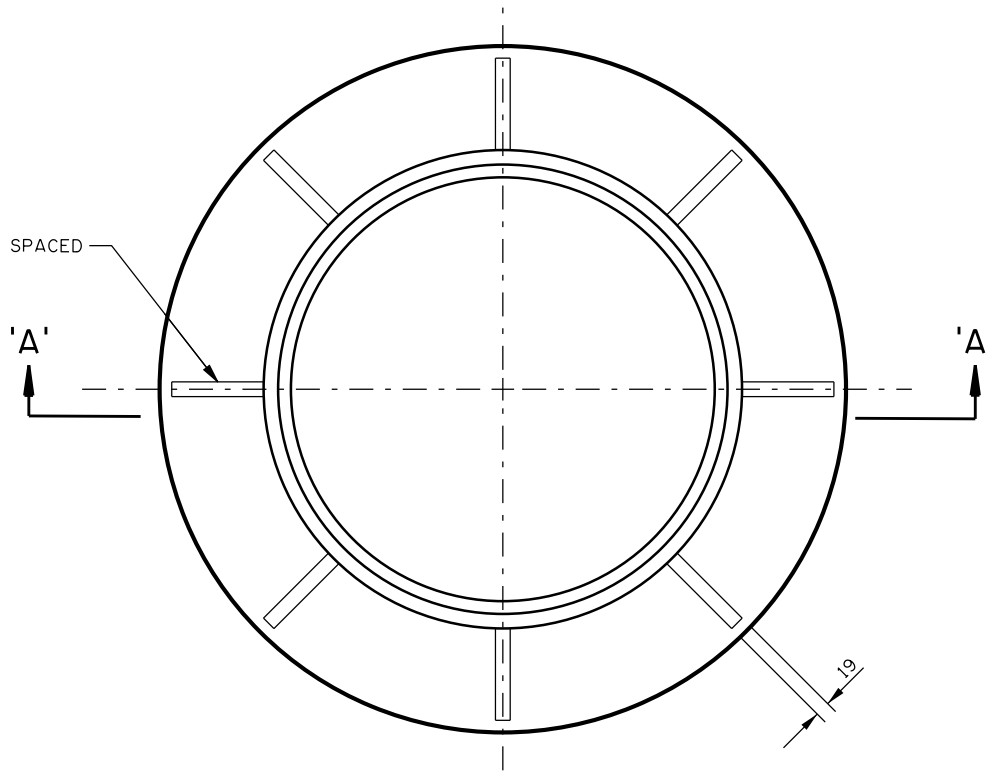

PLAN

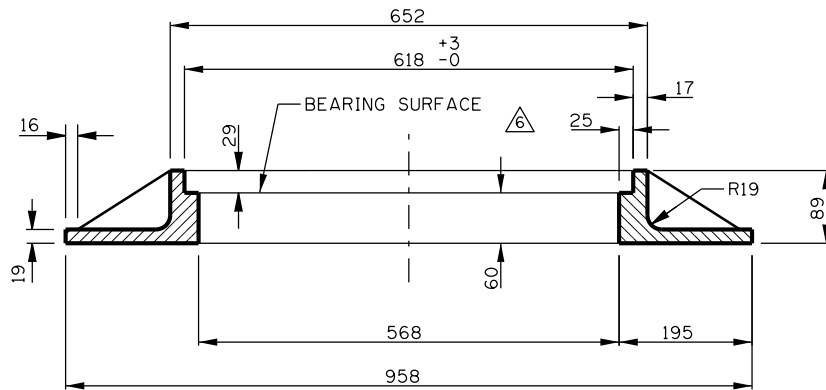

SECTION 'A-A'

MATERIAL SPECIFICATIONS:

1. DUCTILE IRON TO CONFORM TO A.S.T.M. A536 GRADE 80-55-06.
2. BEARING SURFACE SHALL BE GROUND OR MACHINED TO PREVENT ROCKING.
3. COATED CASTINGS ACCEPTED ONLY WHEN REQUIRED BY CITY.

NOTE:

NOT TO BE USED IN GRAVEL LANES (OR GRAVEL ROADS) WITHOUT PRIOR APPROVAL OF MANAGER, INFRASTRUCTURE PLANNING.

DIMENSIONS ARE IN MILLIMETRES UNLESS OTHERWISE NOTED

6	2020/01/14	REVISED DIMENSIONS	S.P.	Date		SEWER CONSTRUCTION	Sheet
5	2018/02/15	REVISED NOTE	M.C.	2001/12/20			
4	2017/01/11	REVISED NOTE	M.C.	Scale		90mm SHALLOW MANHOLE FRAME	4A
3	2014/02/01	ASPHALT VARNISH COATING CHANGED		N.T.S			
2	2006/10/01	WASTEWATER ENGINEERING CHANGE TO INFRASTRUCTURE PLANNING		Approved by		452.1001.031	File Number
1	2004/10/01	ADDED NOTE & SHEET NAME CHANGED		for The City of Calgary			
No.	Date	Revision	App'd				

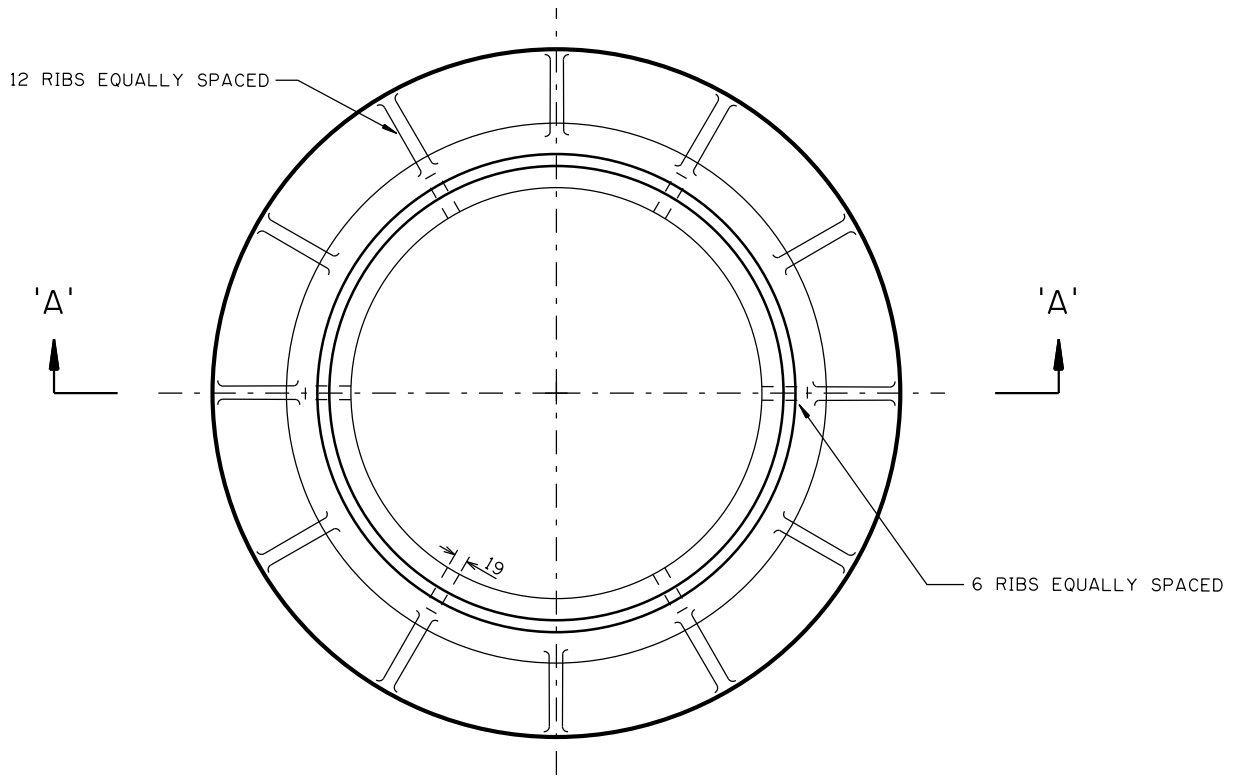

PLAN

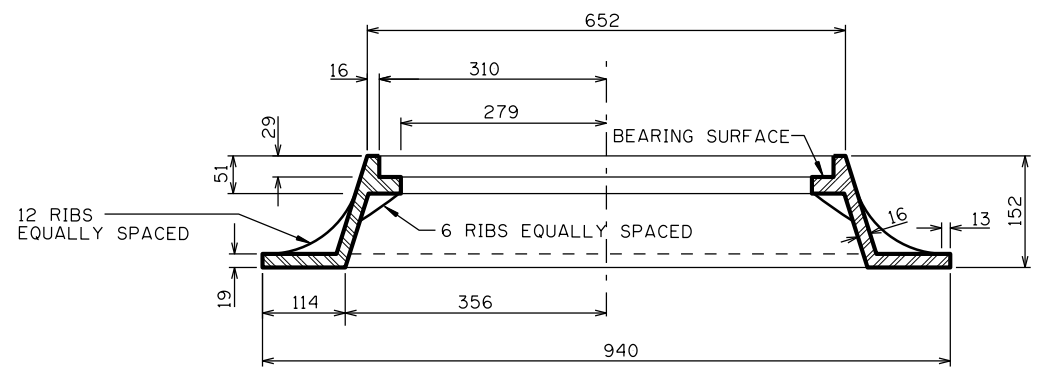

SECTION 'A-A'

MATERIAL SPECIFICATIONS:

- 1. GREY CAST IRON TO CONFORM TO A.S.T.M A48 (LATEST EDITION), CLASS 35B.
- 2. BEARING SURFACE SHALL BE GROUND OR MACHINED TO PREVENT ROCKING
- 3. NOMINAL MASS = 88 KILOGRAMS ±5%
- 4. COATED CASTINGS ACCEPTED ONLY WHEN REQUIRED BY CITY.

NOTE:

NOT TO BE USED IN GRAVEL LANES (OR GRAVEL ROADS) WITHOUT PRIOR APPROVAL OF MANAGER, INFRASTRUCTURE PLANNING.

DIMENSIONS ARE IN MILLIMETRES UNLESS OTHERWISE NOTED

5	2018/02/15	REVISED NOTE	MC	Date	1999/09/14		SEWER CONSTRUCTION	Sheet	5
4	2017/01/11	REVISED NOTE	MC	Scale	N.T.S.				
3	2014/02/01	ASPHALT VARNISH NOTE		Approved by					
2	2006/10/01	WASTEWATER ENGINEERING FIXED TO INFRASTRUCTURE PLANNING		for The City of Calgary					
2	2004/10/01	SHEET NAME CHANGED						File Number	452.1001.014
1	2004/10/01	ADDED NOTE							
No.	Date	Revision	App'd						

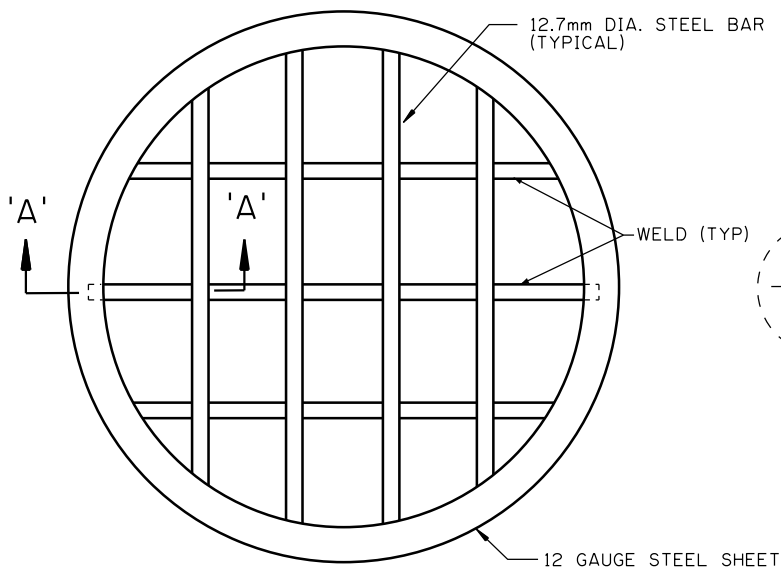

TOP VIEW- SAFETY GRATE

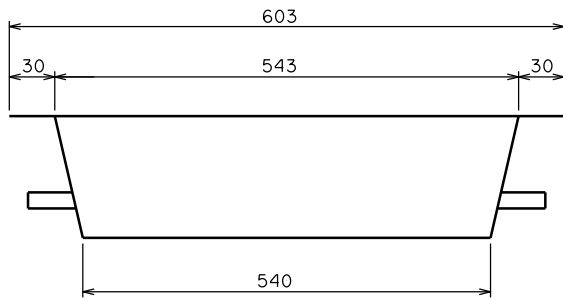

SIDE VIEW- SAFETY GRATE

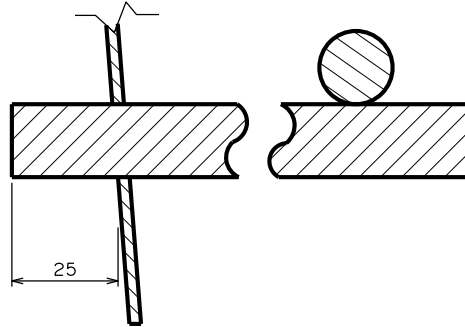
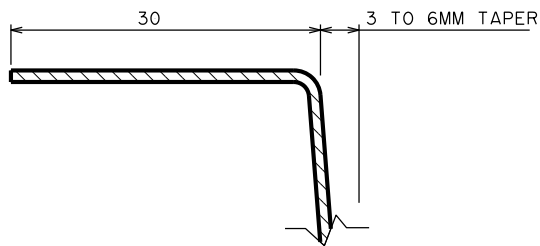

SECTION 'A-A'

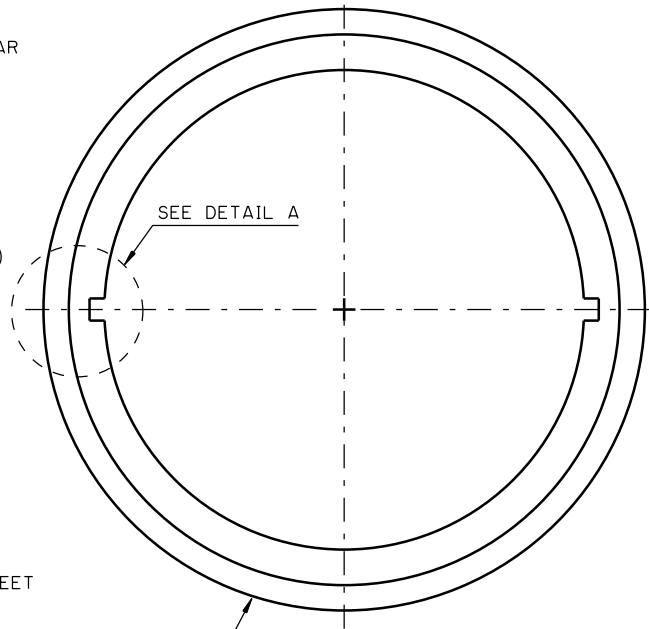

**TOP VIEW
MANHOLE RIM**

SEE SHEET 4 - FILE #452.1001.013
OR SHEET 5 - FILE #452.1001.014

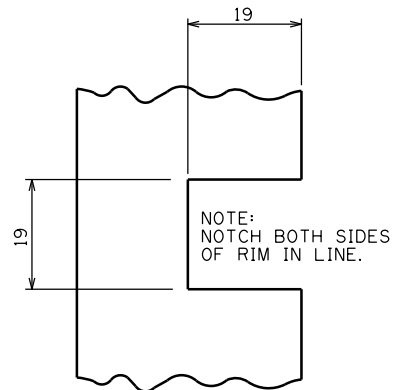

DETAIL A

NOTES:

- THE SAFETY GRATE IS TO BE USED ONLY IN MANHOLES WHERE THERE IS DANGER OF THE MANHOLE LID BEING PUSHED OFF DUE TO SURCHARGING, OR AT THE DISCRETION OF THE SEWER DESIGN ENGINEER.
- UPON INSTALLATION TURN GRATE ONE HALF TURN TO SECURE.

MATERIAL SPECIFICATIONS:

- △ - COATED CASTINGS ACCEPTED ONLY WHEN REQUIRED BY CITY

DIMENSIONS ARE IN MILLIMETRES UNLESS OTHERWISE NOTED

No.	Date	Revision	App'd
1	2018/02/15	REVISED NOTES	MC

Date
1999/09/14
Scale
N.T.S.
Approved by
[Signature]
for The City of Calgary

SEWER CONSTRUCTION

**MANHOLE FRAME
SAFETY GRATING**

Sheet
5A
File Number
452.1001.028

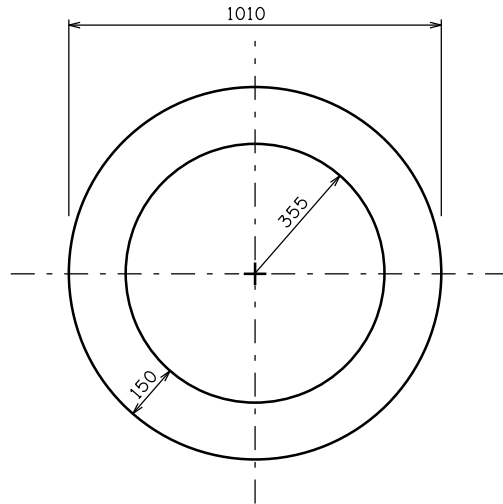

TOP VIEW

COMMON TO ALL COLLARS

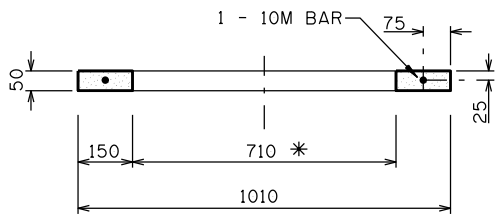

SECTION 50 COLLAR ⚠

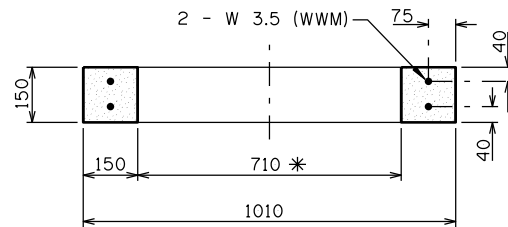

SECTION 150 COLLAR

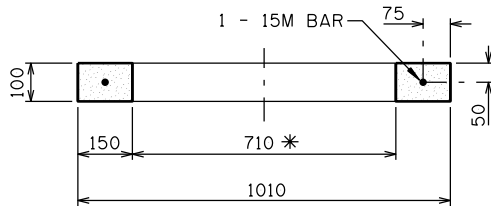

SECTION 100 COLLAR

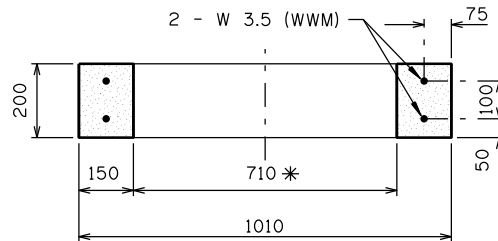

SECTION 200 COLLAR

MATERIAL SPECIFICATIONS: ⚠

(ALL SPECIFICATIONS & STANDARDS REFER TO LATEST EDITION)

1. CEMENT: SULPHATE RESISTANT TYPE: TYPE HS (TYPE 50) TO CSA A3001 OR TYPE V TO ASTM C150
2. CONCRETE COMPRESSIVE STRENGTH: 35 MPa @ 28 DAYS
3. AIR CONTENT: 4 TO 7% EXCEPT WHERE NO-SLUMP CONCRETE IS USED
4. REINFORCING STEEL: DEFORMED BARS TO CSA G30.18
fy=400 MPa
5. WELDED WIRE REINFORCEMENT: TO ASTM A185.
fy=450 MPa

⚠

*** NOTE:** ⚠

FOR SANITARY MANHOLES (8.0m OR DEEPER), LID AND COVER SHALL BE AS PER STANDARD DRAWING SHEET #1B

⚠

DIMENSIONS ARE IN MILLIMETRES UNLESS OTHERWISE NOTED

No.	Date	Revision	App'd	Date	1999/09/14	Scale	N.T.S.	Approved by	for The City of Calgary	SEWER CONSTRUCTION	Sheet	6
4	2020/02/07	REVISED NOTE	S.P.									
3	2015/12/08	NOTE FOR DEEP (SANITARY) MH	M.C.									
2	2005/04/07	ADDED SECTION FOR 50mm COLLAR										
1	2004/11/19	Material specifications revised manufacturers removed										
											File Number	452.1001.006

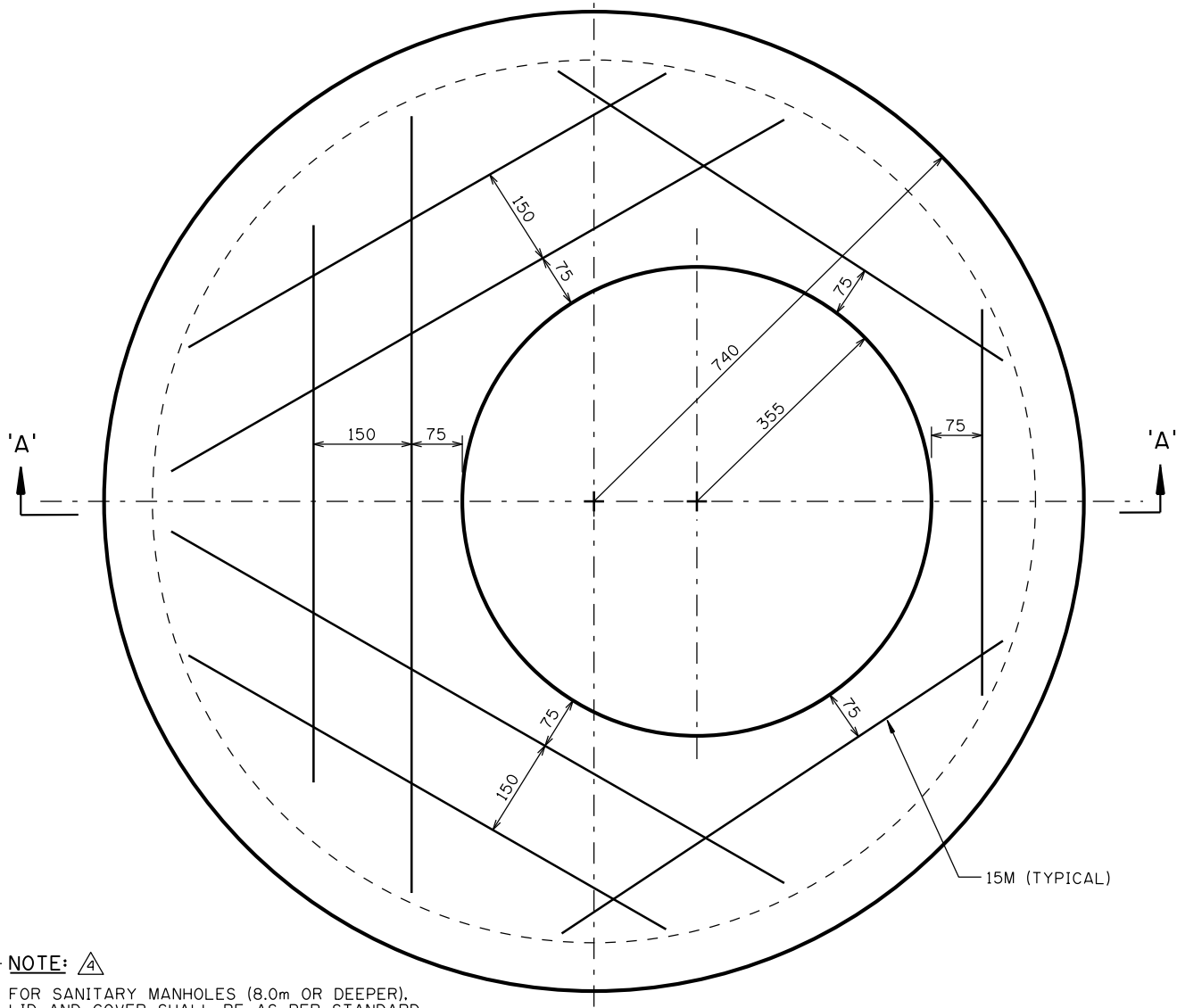

* NOTE: FOR SANITARY MANHOLES (8.0m OR DEEPER), LID AND COVER SHALL BE AS PER STANDARD DRAWING SHEET #1B

PLAN

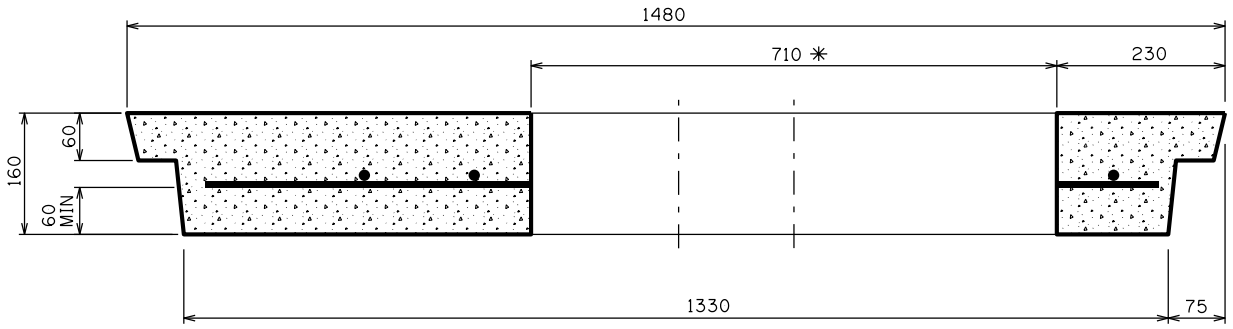

SECTION 'A-A'

MATERIAL SPECIFICATIONS:

ALL SPECIFICATIONS & STANDARDS REFER TO LATEST EDITION)

1. MANUFACTURED TO ASTM C478 & CSA 257.4
2. CEMENT: SULPHATE RESISTANT TYPE: TYPE HS (TYPE50) TO CSA A3001 OR TYPE V TO ASTM C150
3. CONCRETE COMPRESSIVE STRENGTH : 35 MPa @ 28 DAYS
4. CONCRETE COVER = 25mm MIN
5. AIR CONTENT: 4 TO 7% EXCEPT WHERE NO-SLUMP CONCRETE IS USED
6. REINFORCING STEEL: DEFORMED BARS TO CSA G30.18. fy=400 MPa
7. LIFT HOOK TO BE 10M REBAR OR EQUIVALENT

DIMENSIONS ARE IN MILLIMETRES UNLESS OTHERWISE NOTED

No.	Date	Revision
5	2020/02/07	REVISED NOTE
4	2015/12/08	NOTE FOR DEEP (SANITARY) MH FRAME
3	2006/10/12	A150 CHANGED TO C150
2	2006/09/18	CHANGED DRAWING TITLE
1	2004/11/01	PIPE MANUFACTURER REMOVED

Date: 1999/09/14
 Scale: N.T.S.
 Approved by:
 for The City of Calgary

SEWER CONSTRUCTION
MANHOLE SLAB TOP

Sheet **7**
 File Number 452.1001.018

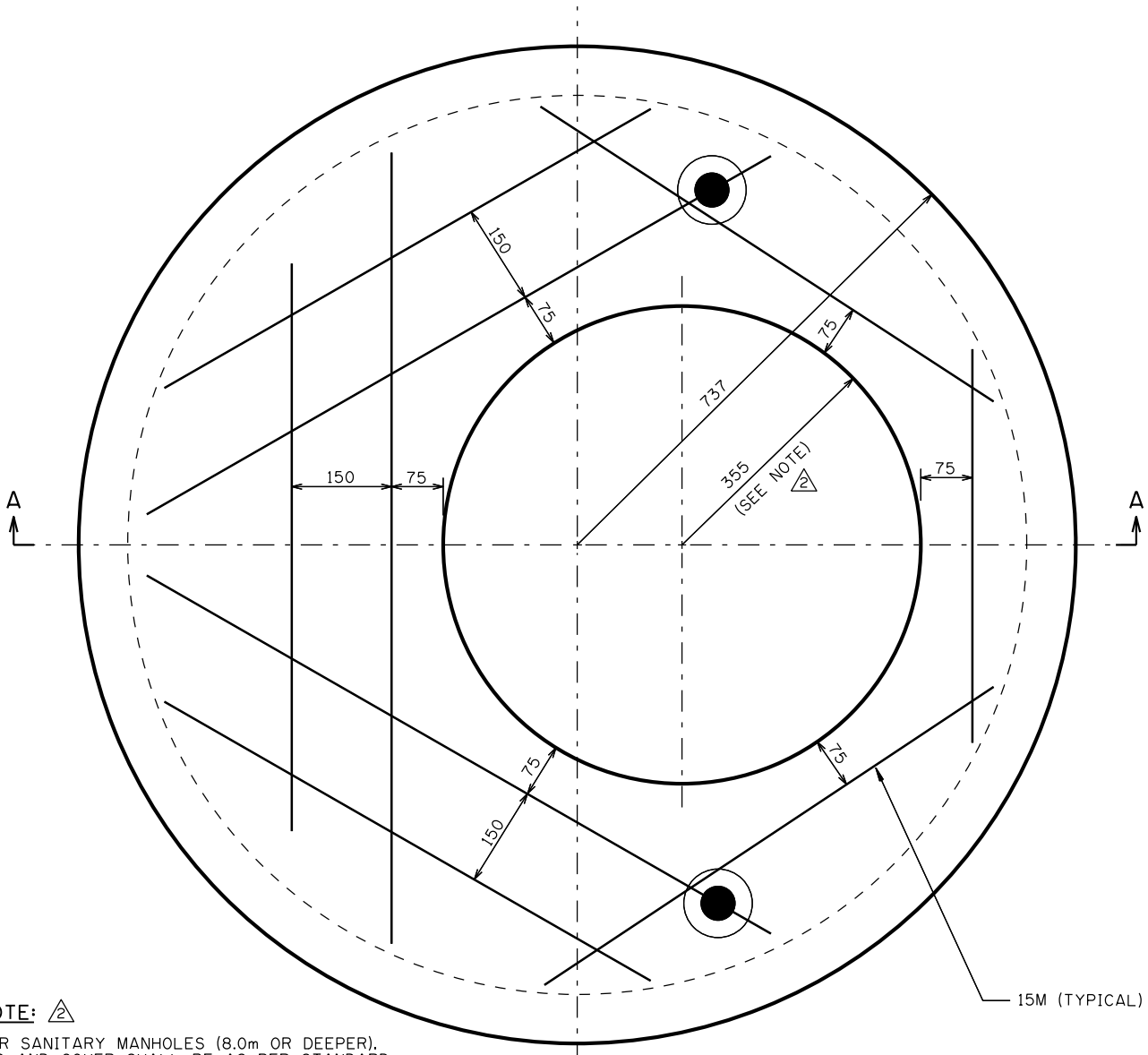

* NOTE: \triangle

FOR SANITARY MANHOLES (8.0m OR DEEPER).
LID AND COVER SHALL BE AS PER STANDARD
DRAWING SHEET #1B

PLAN

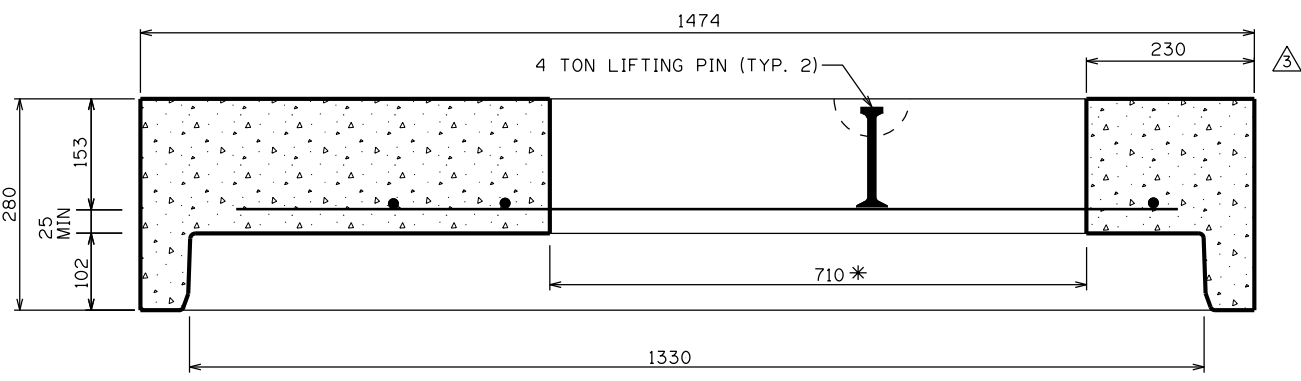

SECTION 'A-A'

MATERIAL SPECIFICATIONS:

(ALL SPECIFICATIONS & STANDARDS REFER TO LATEST EDITION)

- 1. MANUFACTURED TO ATSM C478 & CSA 257.4
- 2. CEMENT: SULPHATE RESISTANT TYPE: TYPE HS (TYPE 50) TO CSA A3001 OR TYPE V TO ASTM C150.
- 3. CONCRETE COMPRESSIVE STRENGTH: 35 MPa @ 28 DAYS.
- 4. CONCRETE COVER = 25mm MINIMUM.
- 5. AIR CONTENT: 4% TO 7% EXCEPT WHERE NO-SLUMP CONCRETE IS USED.
- 6. REINFORCING STEEL: DEFORMED BARS TO CSA G30.18, fy= 400 MPa.

DIMENSIONS ARE IN MILLIMETRES
UNLESS OTHERWISE NOTED

No.	Date	Revision	App'd
3	2020/02/11	REVISED NOTE, ADDED DIMENSION	S.P.
2	2015/12/08	NOTE FOR DEEP (SANITARY) MH FRAME	M.C.
1	2006/10/12	A150 CHANGED TO C150	

Date
2004/10/29
Scale
N.T.S.
Approved by

for The City of Calgary

SEWER CONSTRUCTION
**SLAB TOP DETAIL
FOR SPIGOT-UP
INSTALLATIONS**

Sheet
7A
File Number
452.1001.032

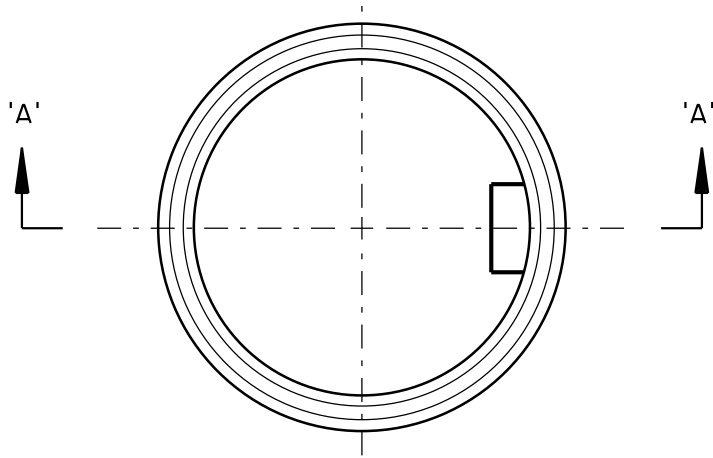

COMMON TO ALL BARRELS
PLAN

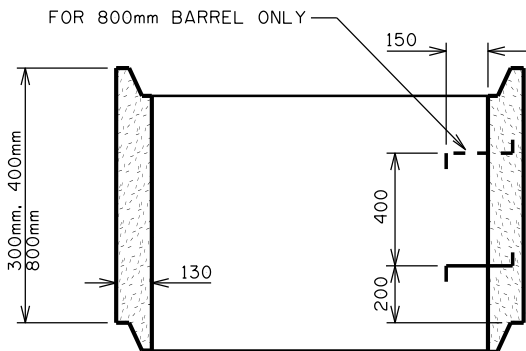

TOP BARREL

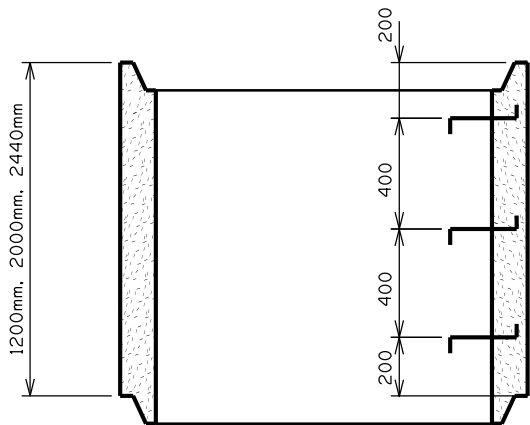

INTERMEDIATE BARREL
SECTION 'A-A'

NOTE:

1. MAXIMUM TWO (2) TOP BARRELS PER MANHOLE. IF REQUIRED.
- △ 2. FOR SANITARY MANHOLES (8.0m OR DEEPER), BARRELS ARE TO BE MINIMUM 1500mm DIAMETER

△ 3. **MATERIAL SPECIFICATIONS:**

(ALL SPECIFICATIONS & STANDARDS REFER TO LATEST EDITION)

1. MANUFACTURED TO ASTM C478 & CSA 257.4
2. CEMENT: SULPHATE RESISTANT TYPE: TYPE HS (TYPE 50) TO CSA A3001 OR TYPE V TO ASTM C150 △ 4
3. CONCRETE COMPRESSIVE STRENGTH: 35 MPa @ 28 DAYS
4. CONCRETE COVER = 25mm MIN △ 4
5. AIR CONTENT: 4 TO 7% EXCEPT WHERE NO-SLUMP CONCRETE IS USED
6. REINFORCING STEEL: DEFORMED BARS TO CSA G30.18.
fy=400 MPa
7. STEPS AS PER STD. DWG. SHEET #9 (452.1001.021) SPACED AT 400mm

DIMENSIONS ARE IN MILLIMETRES UNLESS OTHERWISE NOTED

No.	Date	Revision	App'd
7	2020/02/07	REVISED NOTE	M.C.
6	2015/12/08	NOTE 2 ADDED	
5	2014/08/01	CHANGE SCALE OF DRAWING	
4	2006/10/01	A150 CHANGED TO C150	
3	2004/11/01	MATERIAL SPECIFICATIONS REVISED	
2	2004/10/01	BARREL TYPE & BOTTOM BARREL IN SECTION 'A-A' DELETED.	

Date
1999/09/14

Scale
N.T.S

Approved by
[Signature]

for The City of Calgary

SEWER CONSTRUCTION

MANHOLE RISERS (BARRELS)

Sheet
8

File Number
452.1001.022

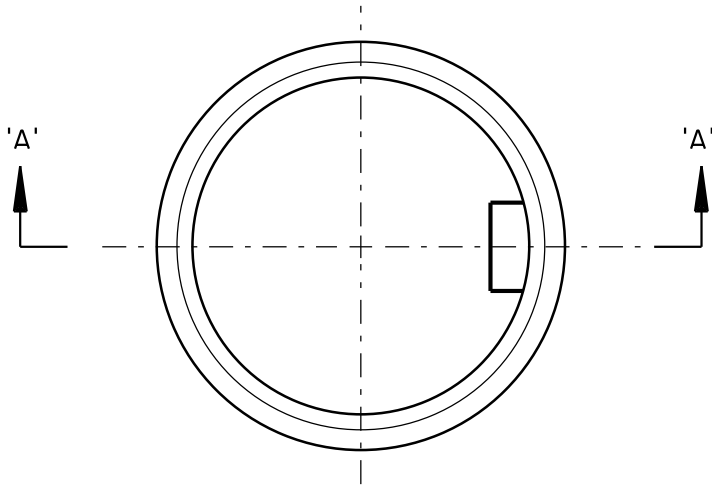

COMMON TO ALL BARRELS
PLAN

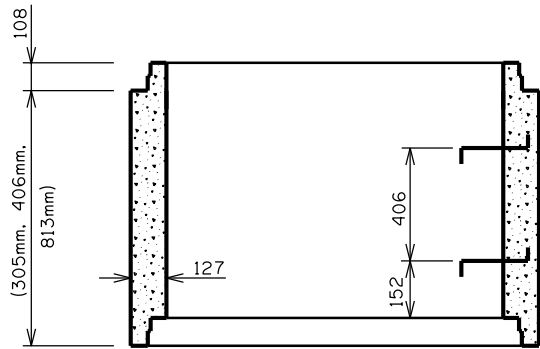

TOP BARREL

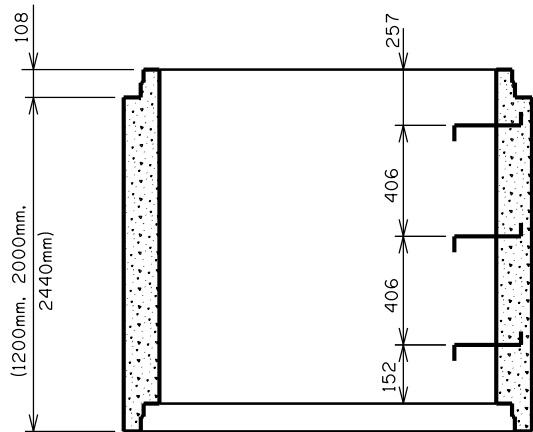

INTERMEDIATE BARREL
SECTION 'A-A'

NOTE:

1. MAXIMUM TWO (2) TOP BARRELS PER MANHOLE, IF REQUIRED.
2. FOR SANITARY MANHOLES (8.0m OR DEEPER), BARRELS ARE TO BE MINIMUM 1500mm DIAMETER.

MATERIAL SPECIFICATIONS:

- (ALL SPECIFICATIONS & STANDARDS REFER TO THE LATEST EDITION)
1. MANUFACTURED TO ASTM C478 & CSA 257.4
 2. CEMENT: SULPHATE RESISTANT TYPE: TYPE HS (TYPE 50) TO CSA A3001 OR TYPE V TO ASTM C150
 3. CONCRETE COMPRESSIVE STRENGTH: 35 MPa @ 28 DAYS
 4. CONCRETE COVER = 25mm MIN
 5. AIR CONTENT: 4 TO 7% EXCEPT WHERE NO-SLUMP CONCRETE IS USED
 6. REINFORCING STEEL: DEFORMED BARS TO CSA G30.18. $f_y=400$ MPa
 7. STEPS AS PER STD. DWG. SHEET #9 (452.1001.021) SPACED AT 400mm

DIMENSIONS ARE IN MILLIMETRES UNLESS OTHERWISE NOTED

No.	Date	Revision	App'd
3	2020/02/07	REVISED NOTE	MC
2	2015/12/08	NOTE 2 ADDED	MC
1	2014/08/01	CHANGE DRAWING SCALE	

Date
2004/11/03

Scale
N.T.S.

Approved by
[Signature]

for The City of Calgary

SEWER CONSTRUCTION

MANHOLE RISER (BARRELS)
SPIGOT-UP INSTALLATIONS

Sheet
8A

File Number
452.1001.035

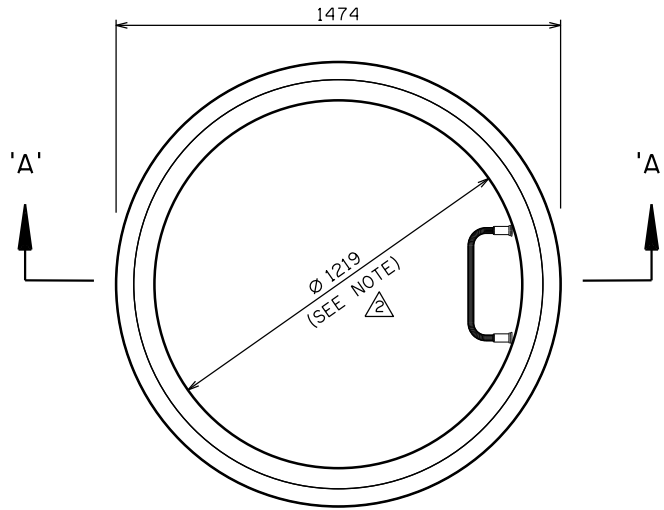

COMMON TO ALL BARRELS
PLAN

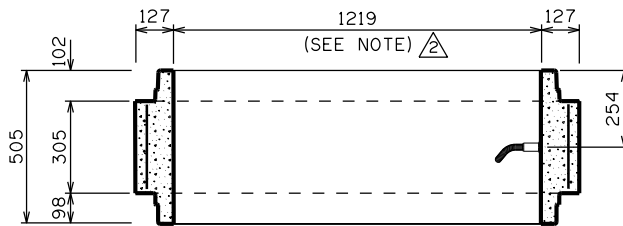

SPIGOT-SPIGOT ADAPTOR

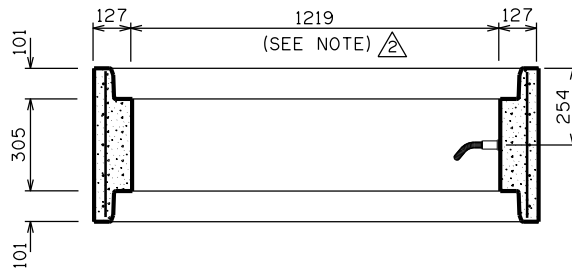

BELL-BELL ADAPTOR
SECTION 'A-A'

MATERIAL SPECIFICATIONS:



(ALL SPECIFICATIONS & STANDARDS REFER TO THE LATEST EDITION)

1. MANUFACTURED TO ASTM C478 & CSA 257.4
2. CEMENT: SULPHATE RESISTANT TYPE: TYPE HS (TYPE 50) TO CSA A3001 OR TYPE V TO ASTM C150 \triangle
3. CONCRETE COMPRESSIVE STRENGTH: 35 MPa @ 28 DAYS \triangle
4. CONCRETE COVER: 25mm MIN
5. AIR CONTENT: 4 TO 7% EXCEPT WHERE NO-SLUMP CONCRETE IS USED
6. REINFORCING STEEL: DEFORMED BARS TO CSA G030.18. $f_y=400$ MPa

NOTE:

FOR SANITARY MANHOLES (8.0m OR DEEPER). BARRELS ARE TO BE MINIMUM 1500mm DIAMETER

DIMENSIONS ARE IN MILLIMETRES UNLESS OTHERWISE NOTED

			Date 2004/11/03		SEWER CONSTRUCTION	Sheet
			Scale N.T.S.			Approved by  for The City of Calgary
3	2020/02/07	REVISED NOTE	MC			
2	2015/12/08	ADDED NOTE	MC			452.1001.034
1	2006/10/01	A150 CHANGED TO C150				
No.	Date	Revision	App'd			

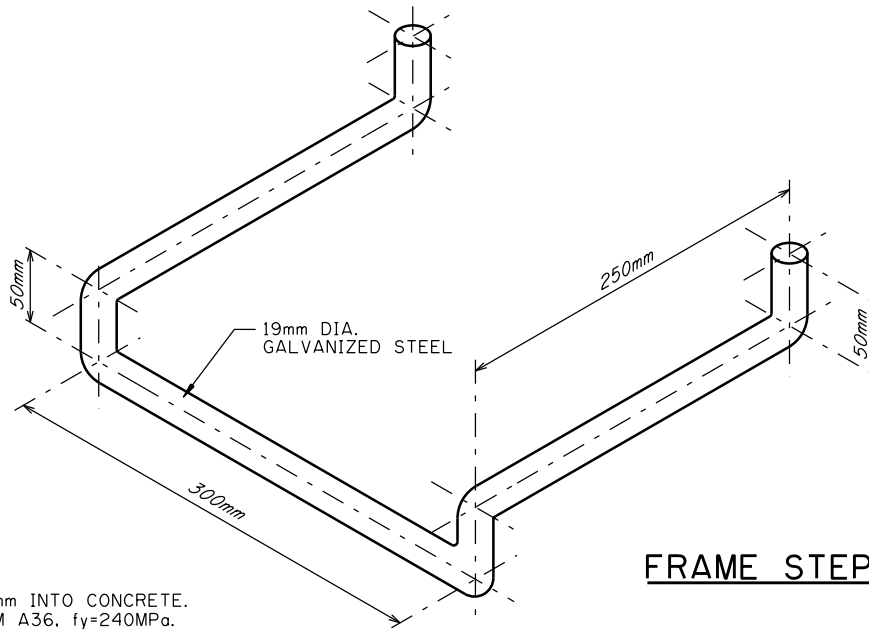

MATERIAL SPECIFICATIONS:

1. ALL STEPS TO BE EMBEDDED 100mm INTO CONCRETE.
2. STEEL BAR: TO CONFORM TO ASTM A36, $f_y=240MPa$.
3. FINISH: HOT-DIP GALVANIZE TO ASTM A123.

FRAME STEP \triangle

MANUFACTURING TOLERANCES:

NOMINAL POLY THICKNESS: 3.0
 TOP OF STEP +1.0
 -0.0
 FACE OF STEP ± 1.0

NOTE:

ALUMINUM TO CONFORM TO CSA CAN3-S157
 MSU - MODEL 360 - ALUM-POLY

ITEM	QTY	MATERIAL	DESCRIPTION
1	1	ALUMINUM 6351-T6	20mm O.D. X 14mm I.D. 6-8425 ALUMINUM EXTRUSION
2	1	LOW DENSITY POLYETHYLENE	VAGN. DUPONT SCLAIR 2111 ON MSU DESIGN
3	2	LOW DENSITY POLYETHYLENE	VAGN. DUPONT SCLAIR 2107

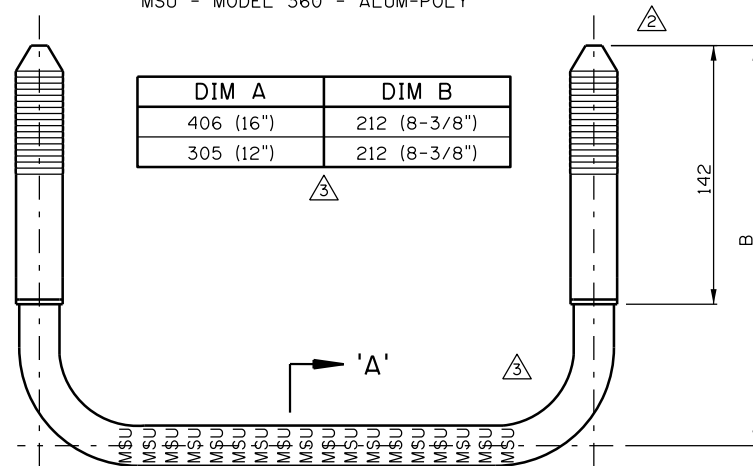

DIM A	DIM B
406 (16")	212 (8-3/8")
305 (12")	212 (8-3/8")

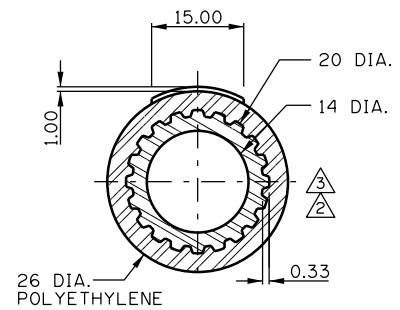

SECTION 'A-A'

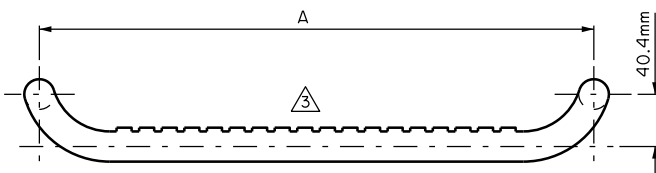

BARREL STEP \triangle

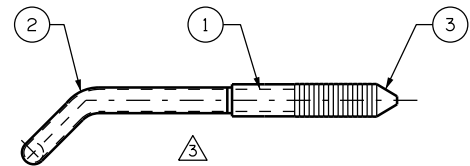

DIMENSIONS ARE IN MILLIMETRES UNLESS OTHERWISE NOTED

No.	Date	Revision
4	2020/02/04	ADDED LABELS AND REVISED TEXT
3	2019/12/18	MODIFIED ALL DETAILS AND NOTES
2	2014/04/01	MODIFIED DIMENSIONS
1	2004/10/01	MODIFIED MATERIAL SPEC.

Date: 1999/09/14
 Scale: N.T.S.
 Approved by: *[Signature]*
 for The City of Calgary

SEWER CONSTRUCTION
MANHOLE STEPS

Sheet: **9**
 File Number: 452.1001.021

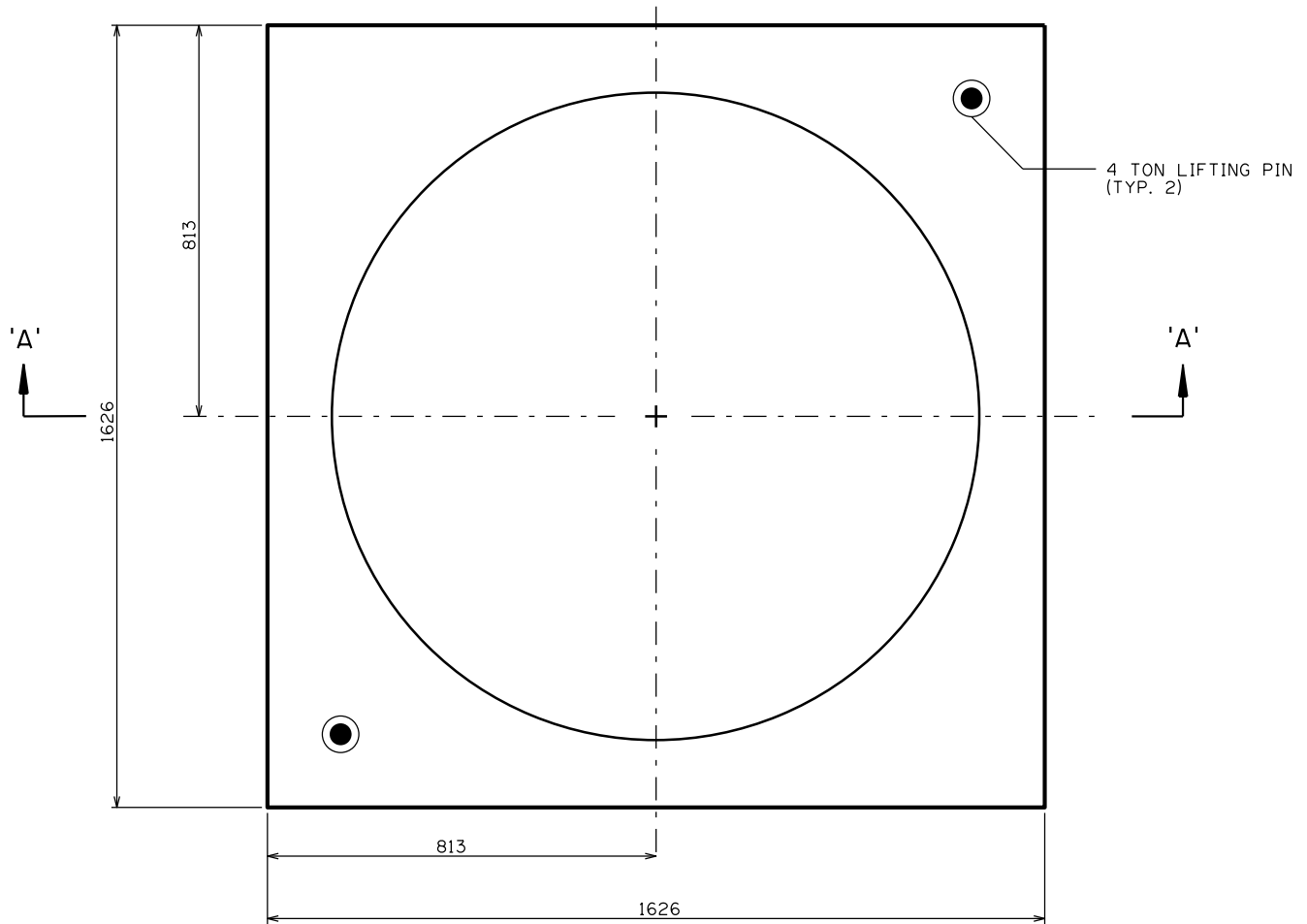

PLAN

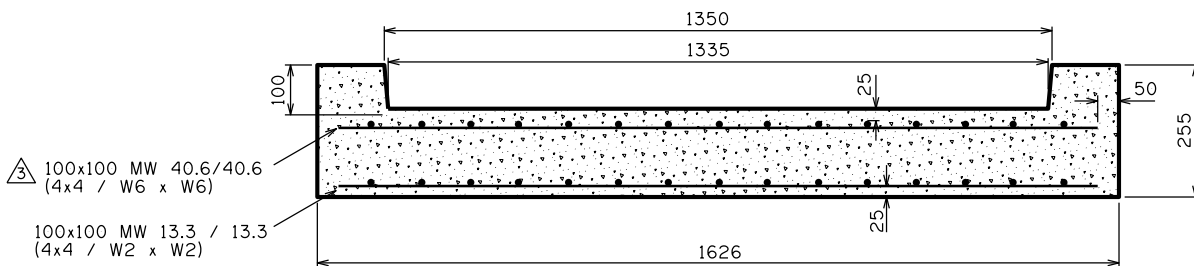

SECTION 'A-A'

MATERIAL SPECIFICATIONS:

(ALL SPECIFICATIONS & STANDARDS REFER TO LATEST EDITION)

1. MANUFACTURED TO ASTM C478 & CSA 257.4
2. CEMENT: SULPHATE RESISTANT TYPE: TYPE HS (TYPE 50) TO CSA A3001 OR TYPE V TO ASTM C150
3. CONCRETE COMPRESSIVE STRENGTH: 35 MPa @ 28 DAYS
4. CONCRETE COVER = 25mm MIN
5. AIR CONTENT: 4 TO 7% EXCEPT WHERE NO-SLUMP CONCRETE IS USED
6. REINFORCING STEEL: DEFORMED BARS TO CSA G30.18, $f_y=400$ MPa
7. LIFT HOOKS TO BE 15M REBAR OR EQUIVALENT
8. WELDED WIRE REINFORCEMENT: 100 x 100 MW 40.6 / 40.6 & 100 x 100 MW 13.3 / 13.3 TO ASTM A185, $f_y=450$ MPa

DIMENSIONS ARE IN MILLIMETRES UNLESS OTHERWISE NOTED

No.	Date	Revision	App'd
4	2020/02/07	REVISED NOTE	
3	2005/09/01	REINFORCEMENT REVISED	M.C.
2	2004/11/01	MATERIAL SPECIFICATIONS REVISED	
1	2004/11/01	PIPE MANUFACTURERS REMOVED	

Date
1999/09/14

Scale
N.T.S.

Approved by
[Signature]

for The City of Calgary

SEWER CONSTRUCTION

**PRECAST MANHOLE
BASE TYPE '5A'**

Sheet
10

File Number
452.1001.019

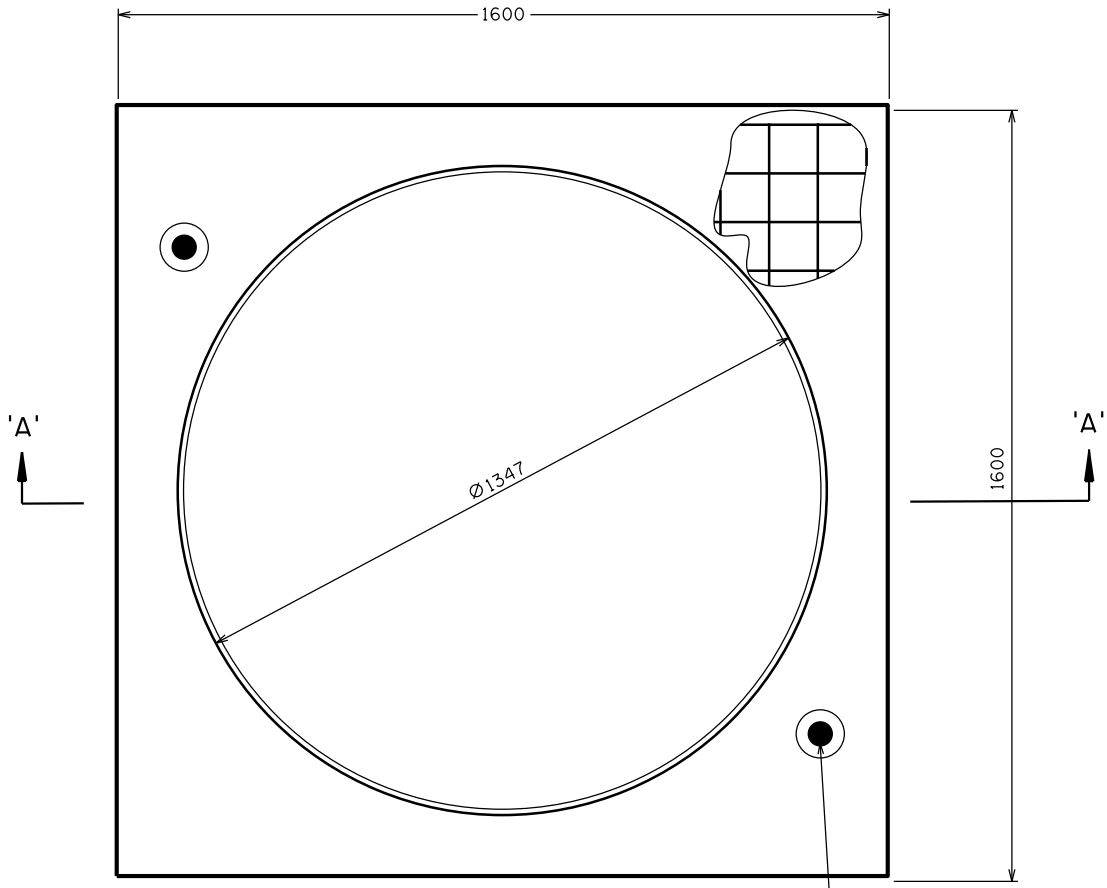

PLAN

4 TON LIFTING PIN (TYP. 2)

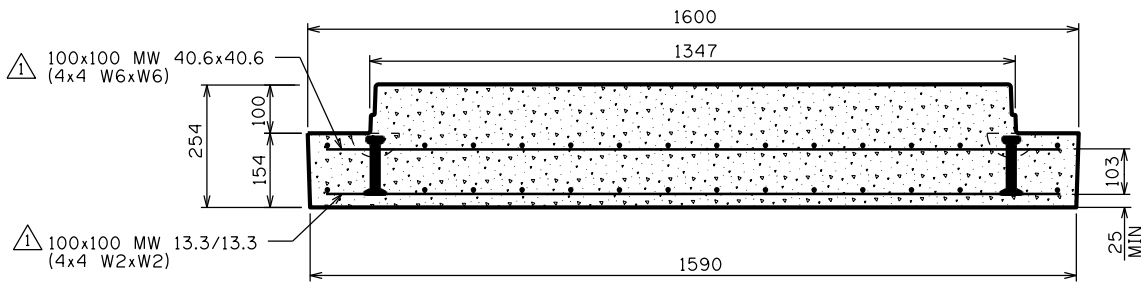

SECTION 'A-A'

MATERIAL SPECIFICATIONS:

(ALL SPECIFICATIONS & STANDARDS REFER TO LATEST EDITION)

1. MANUFACTURED TO ASTM C478 & CSA 257.4.
2. CEMENT: SULPHATE RESISTANT TYPE: TYPE HS (TYPE 50) TO CSA A3001 OR TYPE V TO ASTM C150.
3. CONCRETE COMPRESSIVE STRENGTH: 35 MPa AT 28 DAYS.
4. CONCRETE COVER: 25mm MIN.
5. AIR CONTENT: 4% TO 7% EXCEPT WHERE NON-SLUMP CONCRETE IS USED.
6. REINFORCING STEEL: DEFORMED BARS TO CSA G30.18 $f_y=400MPa$.
7. WELDED WIRE REINFORCEMENT: TO ASTM A185, $f_y=450MPa$
100x100 MW 40.6/40.6 & 100x100 MW 13.3/13.3.

DIMENSIONS ARE IN MILLIMETRES UNLESS OTHERWISE NOTED

No.	Date	Revision
2	2020/02/10	REVISED NOTE
1	2005/09/19	REINFORCEMENT REVISED

Date
2004/10/27

Scale
N.T.S

Approved by
[Signature]

for The City of Calgary

SEWER CONSTRUCTION

PRECAST MANHOLE BASE
TYPE '5A' FOR SPIGOT-UP
INSTALLATIONS

Sheet
10A

File Number
452.1001.033

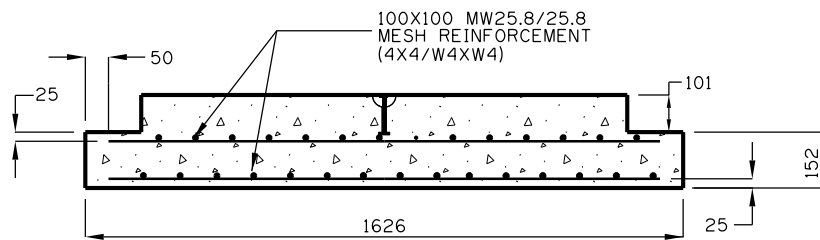
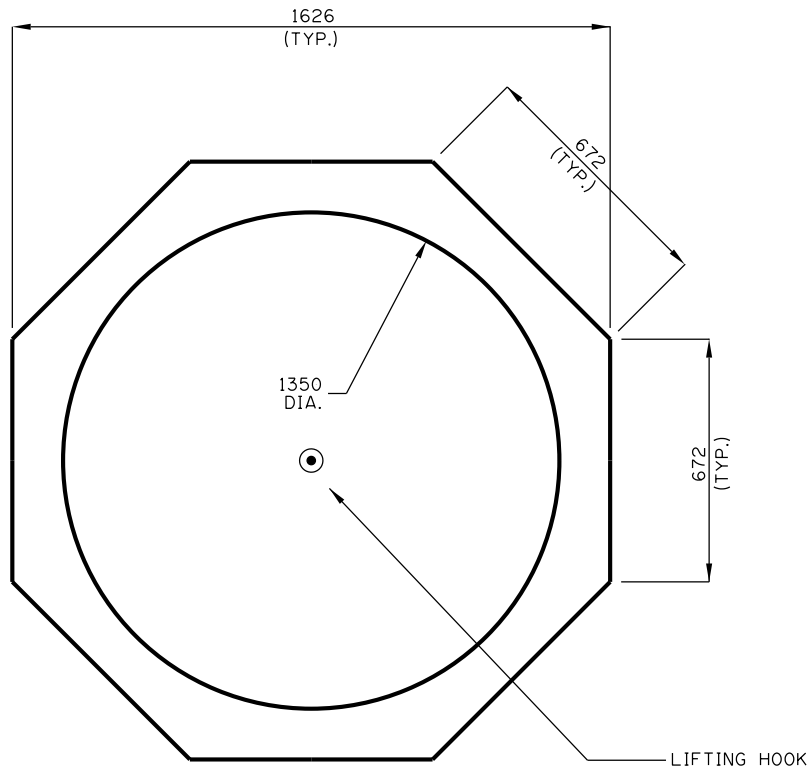

PRECAST BASE SLAB SEPARATE FROM BARREL

MATERIAL SPECIFICATIONS:

(ALL SPECIFICATIONS AND STANDARDS REFER TO LATEST EDITION)

1. MANUFACTURED TO ASTM C478.
2. CEMENT: SULPHATE RESISTANT TYPE HS (TYPE 50) TO CSA A3001 OR TYPE V TO ASTM C150.
- △ 3. CONCRETE COMPRESSIVE STRENGTH 35MPa AT 28 DAYS.
4. AIR CONTENT (TO CAN/CSA A23.1)
5%-8% FOR 10mm AGGREGATE
(EXCEPT WHERE NO SLUMP CONCRETE IS USED)
5. MINIMUM CONCRETE COVER: 25mm
6. REINFORCING STEEL: DEFORMED BARS TO CSA G30.18 fy=400MPa.
7. WELDED WIRE REINFORCEMENT: TO ASTM A185 fy=450MPa.

DIMENSIONS ARE IN MILLIMETRES
UNLESS OTHERWISE NOTED

No.	Date	Revision
1	2020/02/10	REVISED NOTE

Date
2005/09/22

Scale
N.T.S.

Approved by
[Signature]

for The City of Calgary

SEWER CONSTRUCTION

PRECAST OCTAGONAL MANHOLE
BASE TYPE '5A'
FOR SPIGOT-UP INSTALLATIONS

Sheet
11

File Number
452.1001.042

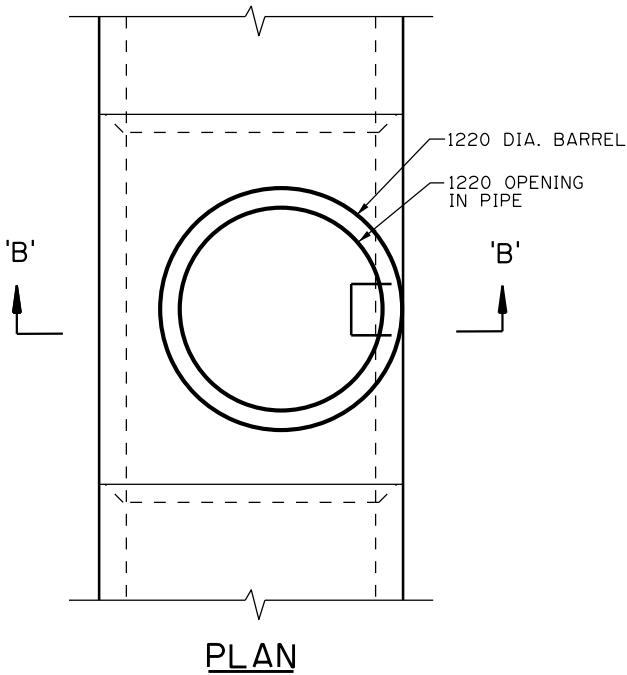

MATERIAL SPECIFICATIONS:

(ALL SPECIFICATIONS & STANDARDS REFER TO LATEST EDITION).

1. CEMENT: SULPHATE RESISTANT TYPE: TYPE HS (TYPE 50) TO CSA A 3001 OR TYPE V TO ASTM C150.
- ② 2. CONCRETE COMPRESSIVE STRENGTH: 35MPa @ 28 DAYS.
- ② 3. AIR CONTENT: 4% TO 7% EXCEPT WHERE NO-SLUMP CONCRETE IS USED.
4. REINFORCING STEEL: DEFORMED BARS TO CSA G30.18 fy = 400MPa.
5. T-RISER SHALL BE MANUFACTURED FROM REINFORCED CONCRETE PIPE CONFORMING TO ASTM C76 AND MANHOLE BARREL CONFORMING TO SHEET #8A (452.1001.035).

NOTES:

- ② 1. THIS TYPE OF MANHOLE IS TO BE USED ONLY ON MAINS OF 1200 DIAMETER OR LARGER.
2. TO BE USED ONLY WHERE THERE IS NO CHANGE IN DIRECTION OF FLOW (STRAIGHT-THROUGH FLOW).
3. MANHOLE STEPS TO EXTEND FROM RISEN SECTION TO SPRING LINE OF PIPE.
- ② 4. NO RETROFIT ON EXISTING PIPE SHALL BE ALLOWED.
- ④① 5. ALTERNATIVE PRODUCTS MAY BE USED SUBJECT TO WATER RESOURCES APPROVAL.
- ③ 6. PIPE EMBEDMENT AS PER SHEET #33.
- ⑤ 7. SEWER MAIN TIE-IN'S TO T-RISER PREFABRICATED MANHOLE SECTION ARE NOT ALLOWED.

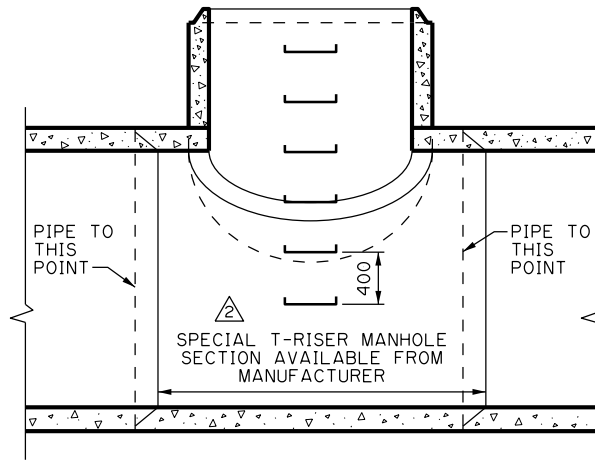
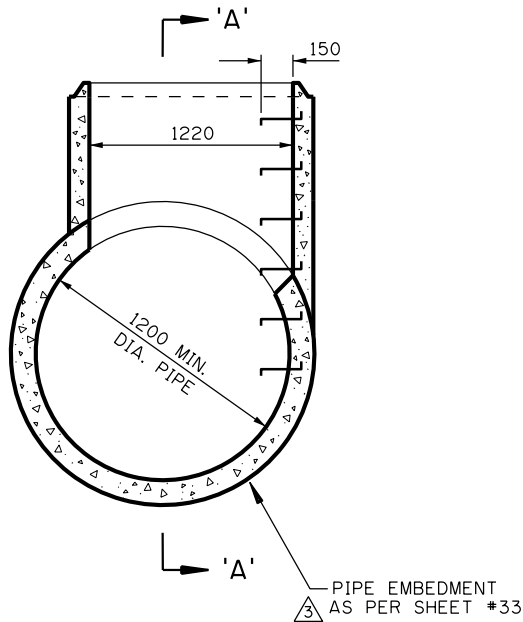

DIMENSIONS ARE IN MILLIMETRES UNLESS OTHERWISE NOTED

No.	Date	Revision	M.C.
6	2020/02/10	REVISED NOTE	
5	2008/09/16	ADDED NOTE	
4	2006/10/12	WASTEWATER CHANGED TO WATER RESOURCES	
3	2005/09/13	BEDDING CHANGED AND TURNED SPIGOT 'UP'	
2	2004/11/22	REVISED NOTE	
1	2002/12/04	REVISED NOTE	

Date
1999/09/14

Scale
N.T.S.

Approved by
[Signature]

for the City of Calgary

SEWER CONSTRUCTION

T-RISER MANHOLE

Sheet
12

File Number
452.1001.009

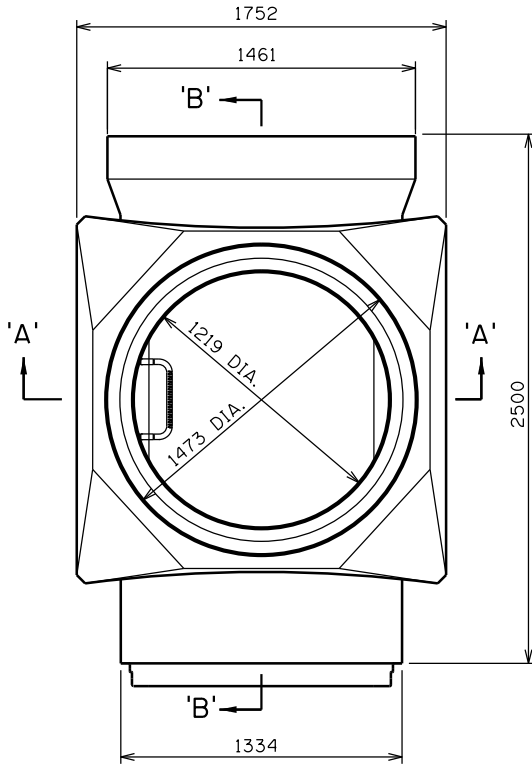

PLAN VIEW

MATERIAL SPECIFICATIONS:

(ALL SPECIFICATION & STANDARDS REFER TO LATEST EDITION)

1. CEMENT: SULPHATE RESISTANT TYPE: TYPE HS (TYPE 50) TO CSA A3001 OR TYPE V TO ASTM C150.
2. CONCRETE COMPRESSIVE STRENGTH: 35MP_a AT 28 DAYS
3. AIR CONTENT (TO CAN/CSA A23.1): 4% TO 7% EXCEPT WHERE NO SLUMP CONCRETE IS USED.
4. REINFORCING STEEL: DEFORMED BARS TO CSA G30.18 f_y = 400MP_a.
5. MINIMUM CONCRETE COVER: 25mm
6. T-RISER SHALL BE MANUFACTURED FROM REINFORCED CONCRETE PIPE CONFORMING TO ASTM C76 AND MANHOLE RISERS CONFORMING TO SHEET #8A (452.1001.035).

NOTE:

1. THIS MANHOLE IS TO BE USED ONLY ON MAINS OF 1050 DIAMETER.
2. TO BE USED ONLY WHERE THERE IS NO CHANGE IN DIRECTION OF FLOW (STRAIGHT THROUGH FLOW).
3. MANHOLE STEPS TO EXTEND FROM RISEN SECTION TO SPRING LINE OF PIPE.
4. NO RETROFIT ON EXISTING PIPE SHALL BE ALLOWED.
5. ALTERNATIVE PRODUCTS AND BEDDING MAY BE USED SUBJECT TO WATER RESOURCES APPROVAL.
6. PIPE EMBEDMENT AS PER SHEET #33.

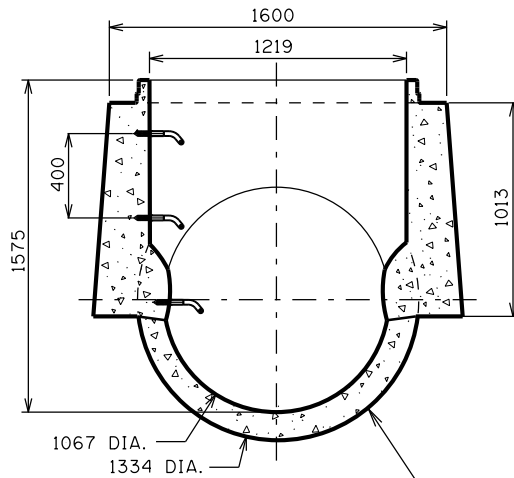

SECTION 'A-A'

PIPE EMBEDMENT AS PER SHEET #33

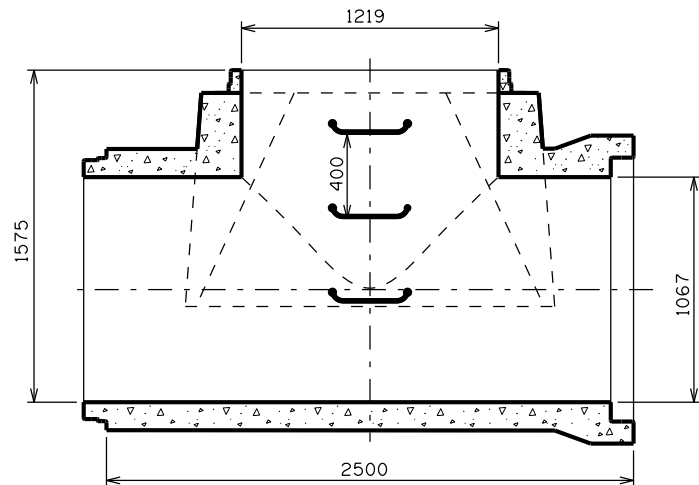

SECTION 'B-B'

DIMENSIONS ARE IN MILLIMETRES UNLESS OTHERWISE NOTED

No.	Date	Revision	App'd
2	2020/02/10	REVISED NOTE	M.C.
1	2006/12/10	WASTEWATER APPROVAL CHANGED TO WATER RESOURCES APPROVAL	

Date
2005/09/01

Scale
N.T.S

Approved by
[Signature]

for The City of Calgary

SEWER CONSTRUCTION

1050 T-RISER
MANHOLE

Sheet
12A

File Number
452.1001.039

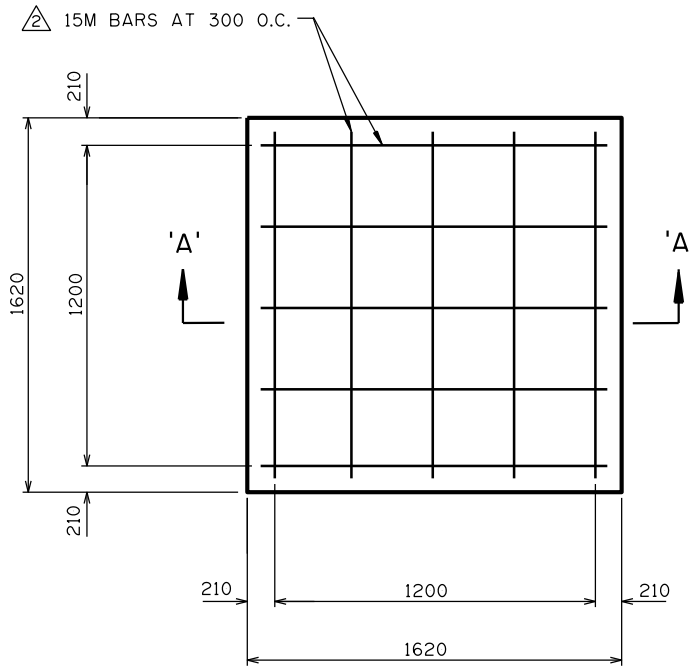

BASE SLAB

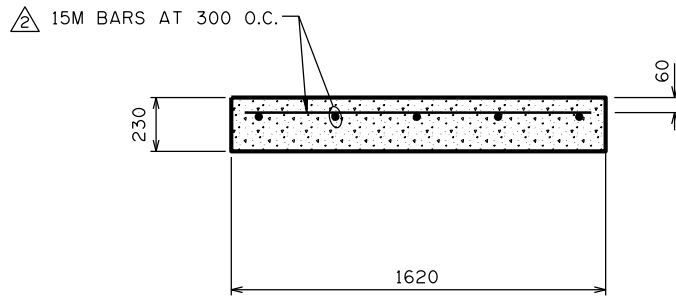

SECTION 'A-A'

MATERIAL SPECIFICATIONS:

(ALL SPECIFICATIONS & STANDARDS REFER TO LATEST EDITION)

1. CEMENT: SULFATE RESISTANT TYPE: TYPE HS (TYPE 50) TO CSA A3001 OR TYPE V TO ASTM C150.
2. CONCRETE COMPRESSIVE STRENGTH: 35MP_a AT 28 DAYS.
3. AIR CONTENT: 4% TO 7% EXCEPT WHERE NO-SLUMP CONCRETE IS USED.
4. REINFORCING STEEL: DEFORMED BARS TO CSA G30.18. $f_y = 400\text{MP}_a$.
5. COVER FOR REINFORCING STEEL SHALL BE 60mm.
6. PROVIDE VERTICAL STEEL DOWELS WHERE REQUIRED.

DIMENSIONS ARE IN MILLIMETRES
UNLESS OTHERWISE NOTED

No.	Date	Revision
3	2020/02/10	REVISED NOTE
2	2005/09/22	REINFORCEMENT REVISED
1	2004/11/19	MATERIAL SPECIFICATIONS ADDED

Date
1999/09/14

Scale
N.T.S.

Approved by
[Signature]

App'd for The City of Calgary

SEWER CONSTRUCTION

FIELD CAST MANHOLE
BASE TYPE '5A'

Sheet
13

File Number
452.1001.020

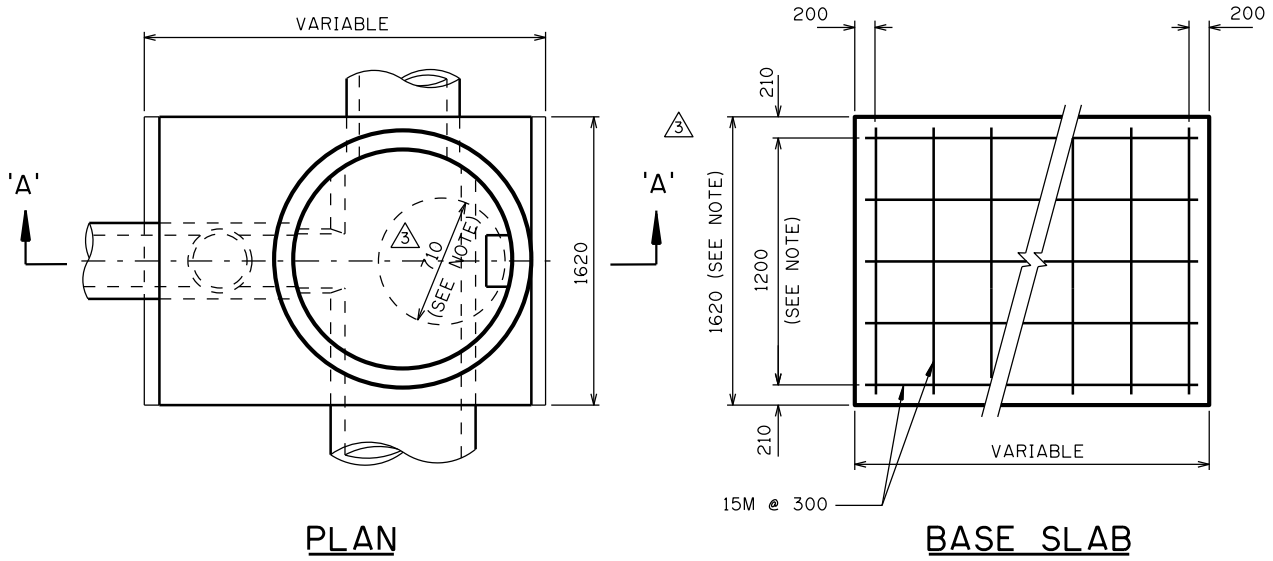

PLAN

BASE SLAB

MATERIAL SPECIFICATIONS:

(ALL SPECIFICATIONS & STANDARDS REFER TO LATEST EDITION)

1. MANUFACTURED TO ASTM C478 & CSA 257.4
2. CEMENT: SULFATE RESISTANT TYPE: TYPE HS (TYPE 50) TO CSA A3001 OR TYPE V TO ASTM C150.
3. CONCRETE COMPRESSIVE STRENGTH: 35MPa AT 28 DAYS.
4. AIR CONTENT: 4% TO 7% EXCEPT WHERE NO-SLUMP CONCRETE IS USED.
5. REINFORCING STEEL: DEFORMED BARS TO CSA G30.18, $f_y = 400MPa$.

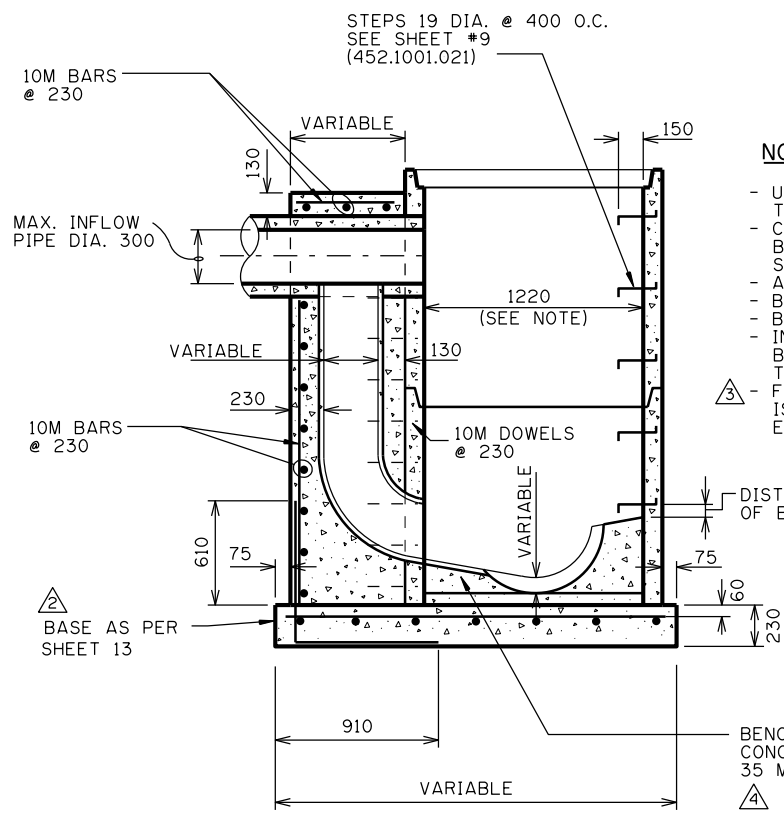

SECTION 'A-A'

NOTES:

- USE EXTERIOR DROP WHEN INCOMING PIPE INVERT IS GREATER THAN 760mm ABOVE OUTGOING PIPE CENTRELINE.
- COVER FOR REINFORCING STEEL SHALL BE 50mm EXCEPT FOR BOTTOM ROW OF BARS IN BASE SLAB WHERE 60mm COVER SHALL BE USED.
- ALL LAPS TO BE 30 BAR DIAMETERS.
- BEND REINFORCING STEEL TO ACCOMMODATE PIPE.
- BELL OR GROOVE END OF PIPE FLUSH WITH CONCRETE.
- INFLOW PIPE DIAMETERS GREATER THAN 250mm MUST BE APPROVED BY THE ENGINEER PRIOR TO CONSTRUCTION. IN NO CASE WILL THE INFLOW PIPE DIAMETER EXCEED 300mm.
- FOR SANITARY MANHOLES (8.0m OR DEEPER), MINIMUM BARREL SIZE IS 1500mm. LID AND COVER SHALL BE TROJAN (T-48) OR APPROVED EQUAL.

DISTANCE BETWEEN BOTTOM STEP AND TOP OF BENCHING NOT TO EXCEED 400mm

BENCHING AND ENCASEMENT CONCRETE STRENGTH TO BE 35 MPa IN 28 DAYS.

DIMENSIONS ARE IN MILLIMETRES UNLESS OTHERWISE NOTED

No.	Date	Revision	App'd
4	2020/06/01	REVISED NOTES	D.N.
3	2015/12/08	NOTE FOR DEEP (SANITARY) MH COVER SIZE	M.C.
2	2005/09/22	REINFORCEMENT REVISED	
1	2004/10/20	REVISED PLAN & SECTION 'A-A' VIEW. MATERIAL SPEC'S ADDED	

Date
1999/09/14

Scale
N.T.S.

Approved by
MS

for The City of Calgary

SEWER CONSTRUCTION

TYPE '5A'
EXTERIOR DROP MANHOLE
(SANITARY ONLY)

Sheet
14

File Number
452.1001.001

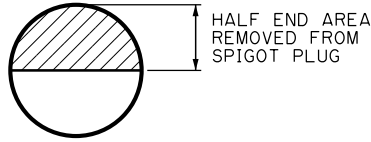

SPIGOT PLUG DETAIL

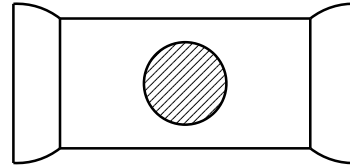

REMOVE 150mm DIAMETER MATERIAL FROM TOP OF TEE TO ALLOW ACCESS FOR CLEANING.

PVC TEE DETAIL

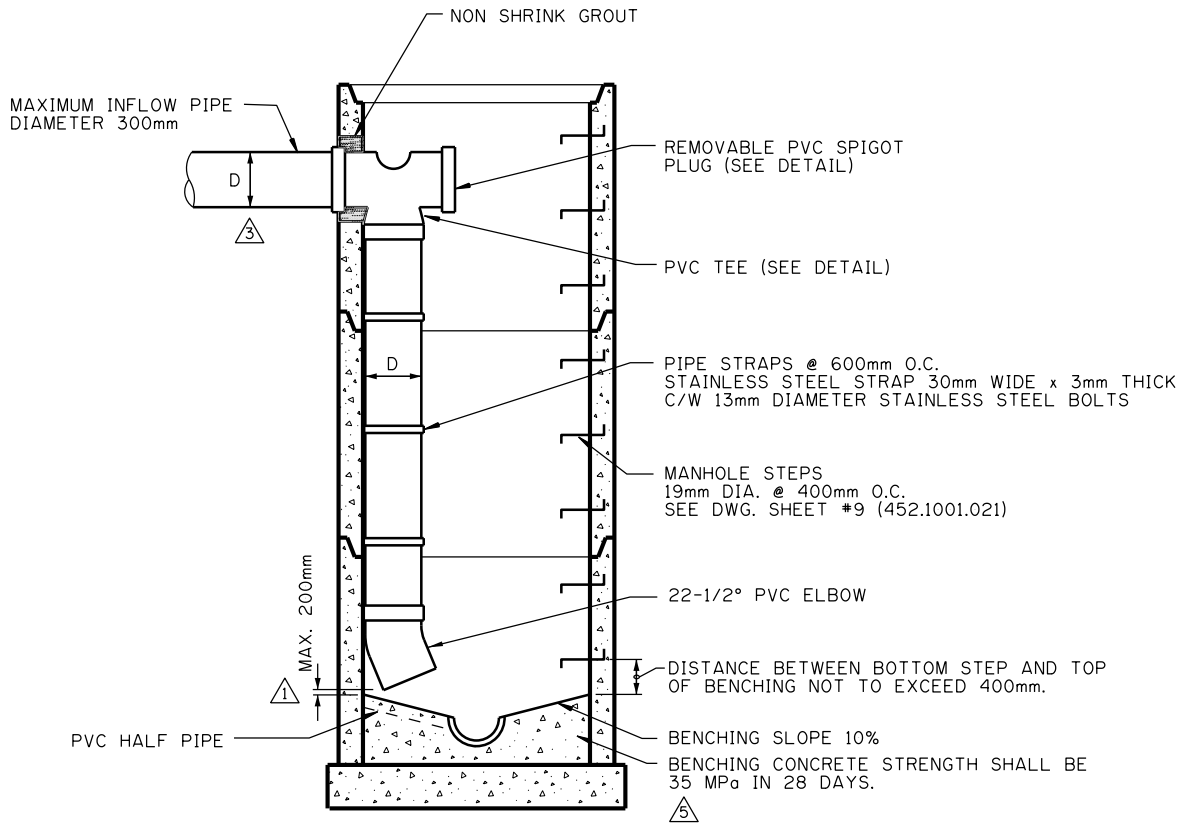

MATERIAL SPECIFICATIONS:

1. PVC PIPE: IN ACCORDANCE WITH CSA, B182.2, SDR35.
2. GROUT SHALL CONFORM TO THE LATEST EDITION OF CALGARY STANDARD SPECIFICATIONS FOR SEWER CONSTRUCTION.

NOTES:

1. THE TEE MAY BE REPLACED BY A PVC INSIDE DROP MANHOLE CROSS MANUFACTURED BY G.P.K. PRODUCTS INC. (OR EQUAL).
2. USE INTERIOR DROP WHEN INCOMING PIPE INVERT IS GREATER THAN 760mm ABOVE OUTGOING PIPE CENTRELINE.
3. ONLY ONE INTERIOR DROP MAY BE USED PER MANHOLE, UNLESS A LARGER DIAMETER MANHOLE IS PROVIDED.
4. FOR RETROFITS A SECOND INTERIOR DROP IS ACCEPTABLE USING AN INTRAFLOW LOW-PROFILE INSIDE DROP SYSTEM. 1.0m CLEARANCE FROM DROP REQUIRED FOR ACCESS.
5. INFLOW PIPE DIAMETERS GREATER THAN 250mm MUST BE APPROVED BY THE ENGINEER PRIOR TO CONSTRUCTION, IN NO CASE WILL THE INFLOW PIPE DIAMETER EXCEED 300mm.
6. DROP PIPE DIAMETER (D) SHALL EQUAL INFLOW PIPE DIAMETER (D).
7. FOR SANITARY MANHOLES (8.0m OR DEEPER), BARRELS ARE TO BE MINIMUM 1500mm DIAMETER.

DIMENSIONS ARE IN MILLIMETRES UNLESS OTHERWISE NOTED

No.	Date	Revision	App'd	Date	Scale	Approved by	SEWER CONSTRUCTION	Sheet
5	2020/06/01	ADDED NOTES AND REVISED NOTES	D.N.	1999/09/14	N.T.S.		TYPE '5A' INTERIOR DROP MANHOLE (SANITARY ONLY)	15
4	2015/12/08	NOTE FOR DEEP (SANITARY) MH COVER SIZE						File Number
3	2005/10/01	DIMENSION LINES ADDED						452.1001.026
2	2004/11/01	ADDED MATERIAL SPECIFICATIONS, EDITED NOTES						
1	2004/10/01	ADDED DIMENSION FROM BOTTOM OF PIPE TO TOP OF BENCHING						

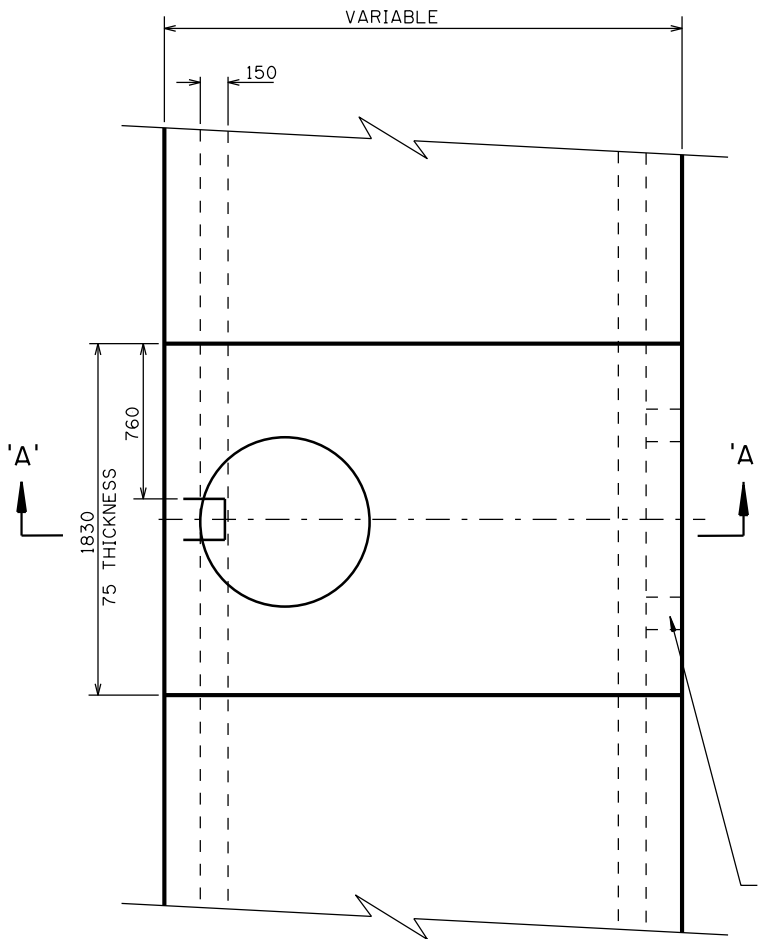

PLAN

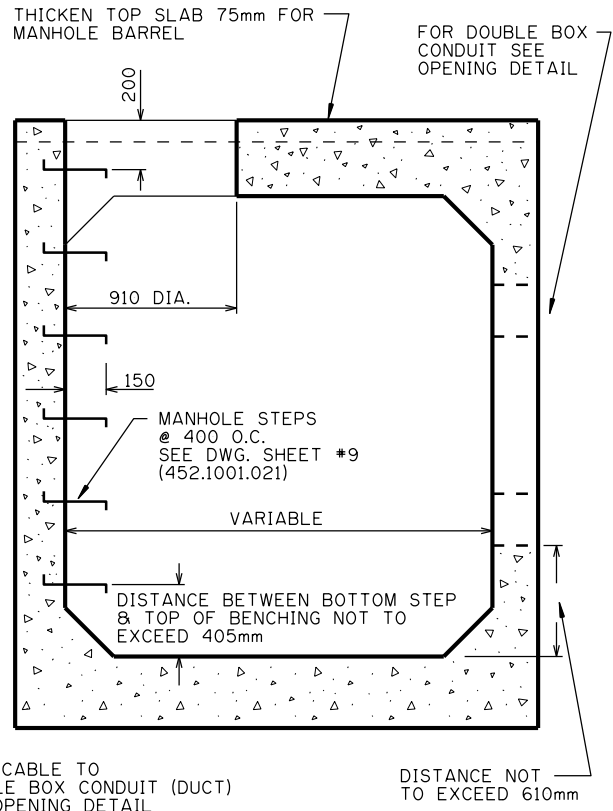

SECTION 'A-A'

MATERIAL SPECIFICATIONS:

(ALL SPECIFICATIONS & STANDARDS REFER TO LATEST EDITION)

1. CEMENT: SULPHATE RESISTANT TYPE: TYPE HS (TYPE 50) TO CSA A3001 OR TYPE V TO ASTM C150
2. AIR CONTENT: 4 TO 7% EXCEPT WHERE NO-SLUMP CONCRETE IS USED
3. BOX CONDUITS (DUCTS): IN ACCORDANCE WITH ASTM I433
 - MINIMUM CONCRETE COMPRESSIVE STRENGTH TO BE 35MP_a
4. MANHOLE SECTIONS: IN ACCORDANCE WITH ASTM C478
 - MINIMUM CONCRETE COMPRESSIVE STRENGTH TO BE 35MP_a

NOTES:

- COVER FOR REINFORCING STEEL SHALL BE 50mm.
- REINFORCING STEEL TO BE SAME GRADE AS DUCT DESIGN.
- PROVIDE AN OPENING IN CENTRE WALL OF DOUBLE BOX CONDUIT AT MANHOLE LOCATION. CUT AND BEND STEEL TO SUIT OPENING IN WALL.
- PROVIDE 40mm CHAMFER ON ALL PERMANENTLY EXPOSED EDGES OF BOX CONDUIT.
- TOP MANHOLE TO BE PLACED 400mm BELOW BOTTOM STEP IN MANHOLE RISER.

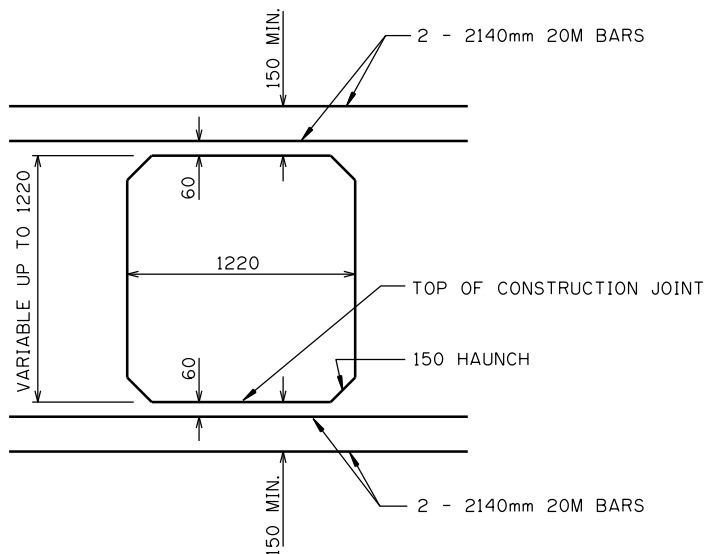

CONDUIT OPENING DETAIL

DIMENSIONS ARE IN MILLIMETRES UNLESS OTHERWISE NOTED

No.	Date	Revision	App'd
3	2020/02/10	REVISED NOTE	M.C.
2	2005/10/01	CHANGED ASTM A150 TO ASTM C150	
1	2004/11/01	ADDED MATERIAL SPECIFICATIONS, CHANGED TITLE	

Date
1999/09/14

Scale
N.T.S.

Approved by
[Signature]

for The City of Calgary

SEWER CONSTRUCTION

STANDARD '5A' MANHOLE FOR BOX CONDUIT (DUCT)

Sheet
16

File Number
452.1001.010

NOTE:

FOR SANITARY MANHOLES (8.0m OR DEEPER),
OPENING SHALL BE 1500mm

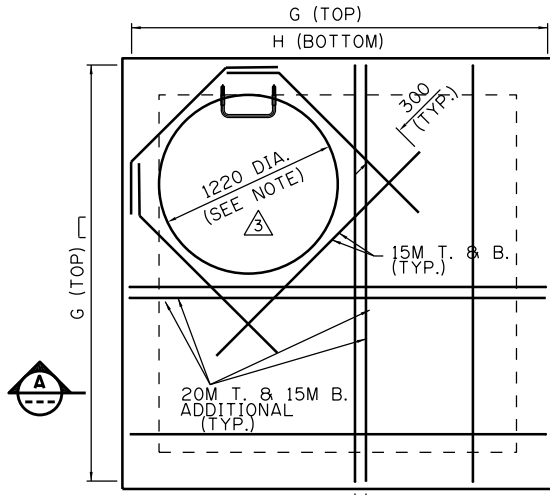

PLAN

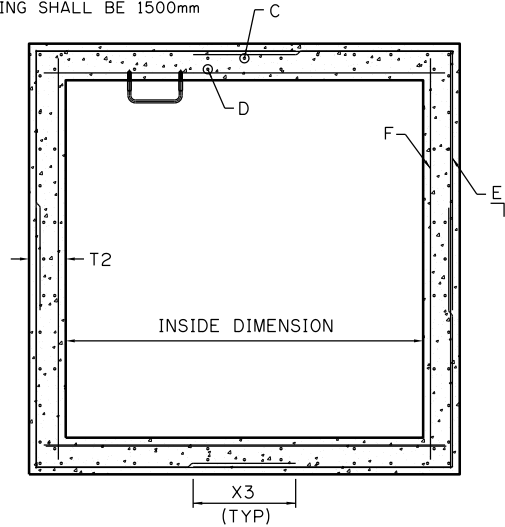

SECTION B

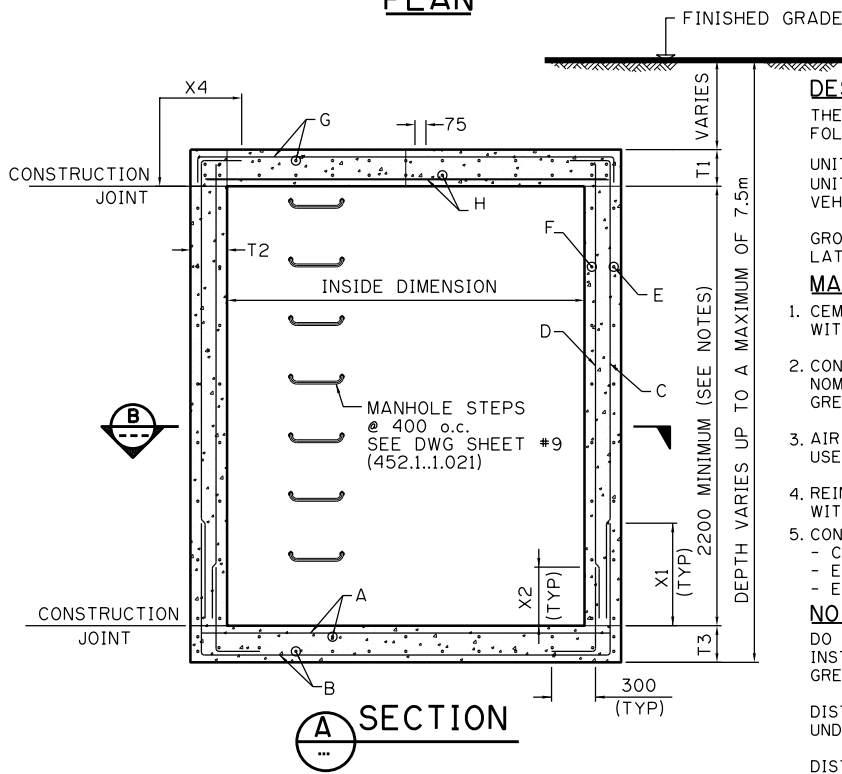

SECTION A

DESIGN PARAMETERS:

THE DESIGN SHOWN IN THE TABLE ARE BASED ON THE FOLLOWING PARAMETERS:

UNIT WEIGHT OF SOIL: 22kN/m³
UNIT WEIGHT OF WATER: 9.8kN/m³
VEHICLE LOAD: BASED ON A CL 800 TRUCK

GROUNDWATER LEVEL: 1.0m BELOW FINISHED GRADE.
LATERAL EARTH PRESSURE COEFFICIENT: 0.5

MATERIAL SPECIFICATIONS:

- CEMENT: SULPHATE-RESISTANT TYPE HS (TYPE 50) IN ACCORDANCE WITH CSA A3001 OR TYPE V IN ACCORDANCE WITH ASTM C150.
- CONCRETE: COMPRESSIVE STRENGTH OF 35MP_a AT 28 DAYS. NOMINAL MAXIMUM SIZE OF COARSE AGGREGATE TO BE NO GREATER THAN 28mm.
- AIR CONTENT: 4% AND 7% EXCEPT WHERE NO-SLUMP CONCRETE IS USED
- REINFORCING STEEL: DEFORMED BARS IN ACCORDANCE WITH CSA G30.18. F_y=400 MP_a.
- CONCRETE CLEAR COVER:
 - CAST AGAINST EARTH: 75mm
 - EXPOSED TO EARTH AND GROUNDWATER : 40mm
 - EXPOSED TO SEWER WATER OR CHLORIDES: 60mm

NOTES:

DO NOT USE THE DESIGNS SHOWN IN THE TABLE FOR ANY INSTALLATION THAT WILL BE SUBJECTED TO LOADS GREATER THAN THAT INDICATED BY THE DESIGN PARAMETERS.

DISTANCE BETWEEN THE TOP OF BENCHING AND THE UNDERSIDE OF THE TOP SLAB TO BE NOT LESS THAN 2200mm.

DISTANCE BETWEEN THE BOTTOM STEP AND TOP OF BENCHING NOT TO EXCEED 400mm

INSIDE DIMENSIONS	T3	BOTTOM SLAB		LAP X1	LAP X2	T2	WALLS				LAP X3	T1	TOP SLAB		LAP X4
		A	B				C	D	E	F			G	H	
* 1220 X 1220	225	10M @ 250	15M @ 250	550	400	225	15M @ 250	10M @ 500	10M @ 250	10M @ 500	400	275	15M @ 250	10M @ 250	550
1525 X 1525	225	10M @ 250	15M @ 250	550	400	225	15M @ 250	10M @ 500	15M @ 300	10M @ 300	550	275	15M @ 250	10M @ 250	550
1830 X 1830	250	10M @ 200	20M @ 200	700	400	225	20M @ 200	10M @ 400	15M @ 350	15M @ 350	550	275	15M @ 200	15M @ 400	700
2135 X 2135	250	15M @ 400	20M @ 200	700	400	225	20M @ 200	10M @ 400	20M @ 350	15M @ 350	700	275	20M @ 200	15M @ 400	700
2440 X 2440	250	15M @ 250	20M @ 250	700	400	250	20M @ 250	10M @ 250	20M @ 400	15M @ 400	700	275	20M @ 250	15M @ 250	700
2745 X 2745	250	15M @ 400	20M @ 200	700	550	250	20M @ 200	15M @ 400	20M @ 300	15M @ 300	700	275	20M @ 200	15M @ 200	700
3050 X 3050	300	15M @ 400	20M @ 200	700	550	300	20M @ 200	15M @ 400	20M @ 350	15M @ 350	700	300	20M @ 200	15M @ 200	700
3660 X 3660	300	15M @ 300	20M @ 150	700	550	300	20M @ 150	15M @ 300	20M @ 200	15M @ 200	700	300	20M @ 150	15M @ 150	700

* 1220 X 1220 NOT PERMITTED ON DEEP MANHOLES

DIMENSIONS ARE IN MILLIMETRES UNLESS OTHERWISE NOTED

No.	Date	Revision
4	2020/02/10	REVISED NOTE
3	2015/12/08	NOTE FOR DEEP (SANITARY) MH COVER SIZE
2	2005/11/16	GENERAL REVISIONS & ADDED REBAR
1	2004/11/19	GENERAL REVISIONS

Date: 2004/11/18
Scale: N.T.S.
Approved by: *[Signature]*
for The City of Calgary

SEWER CONSTRUCTION
CAST-IN PLACE STANDARD TYPE '1' MANHOLE

Sheet: **17**
File Number: 452.1001.002

MATERIAL SPECIFICATIONS:

1. CEMENT: SULPHATE RESISTANT TYPE: TYPE HS (TYPE 50) TO CSA A3001 OR TYPE V TO ASTM C150
2. CONCRETE COMPRESSIVE STRENGTH: 35MPa @ 28 DAYS △
3. AIR CONTENT: 4% TO 7% EXCEPT WHERE NO SLUMP CONCRETE IS USED
4. REINFORCING STEEL: DEFORMED BARS TO CSA G30.18 $f_y=400$ MPa
5. PRECAST MANHOLES TO CONFORM TO ASTM C-478 & CSA A257.4

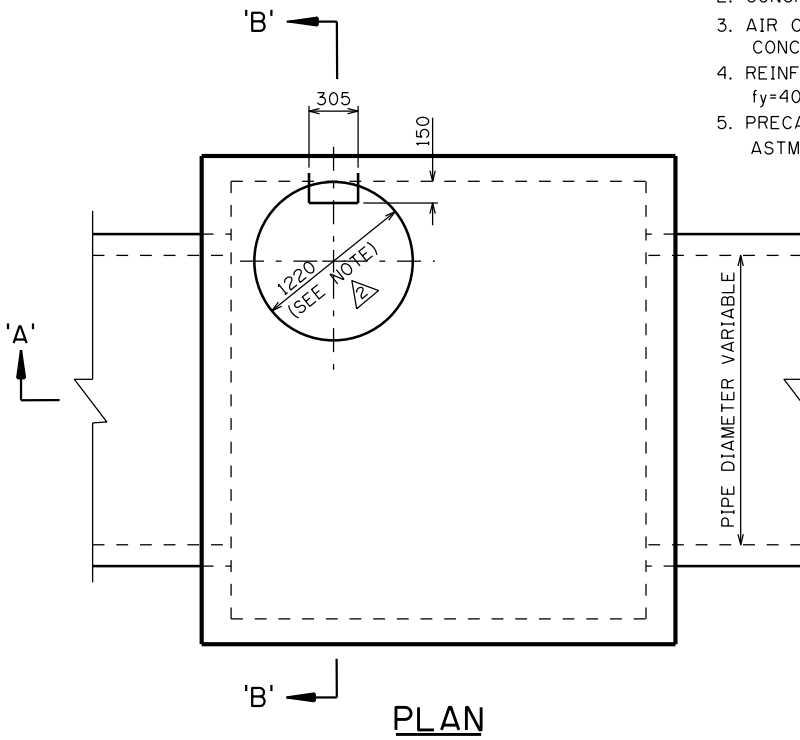

DECISION PARAMETERS:

VEHICLE LOAD BASED ON CL800 TRUCK

NOTES:

- STEP TO BE PLACED 400mm BELOW BOTTOM STEP IN MANHOLE RISERS.
- DISTANCE BETWEEN BOTTOM STEP AND TOP OF BENCHING NOT TO EXCEED 400mm
- MAX. ALLOWABLE DEPTH OF COVER SHALL BE MARKED ON THE WALL OF ALL PRE-CAST TYPE 1-S MANHOLES. THE DEPTH SHALL BE IN METRES

△ - FOR SANITARY MANHOLES (8.0m OR GREATER DEPTH) OPENING SHALL BE 1500mm

PLAN

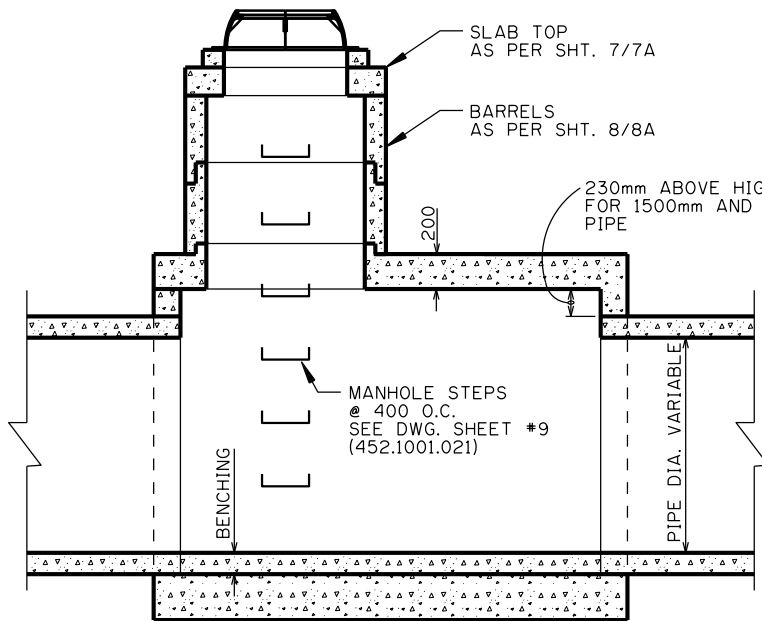

SECTION 'A-A'

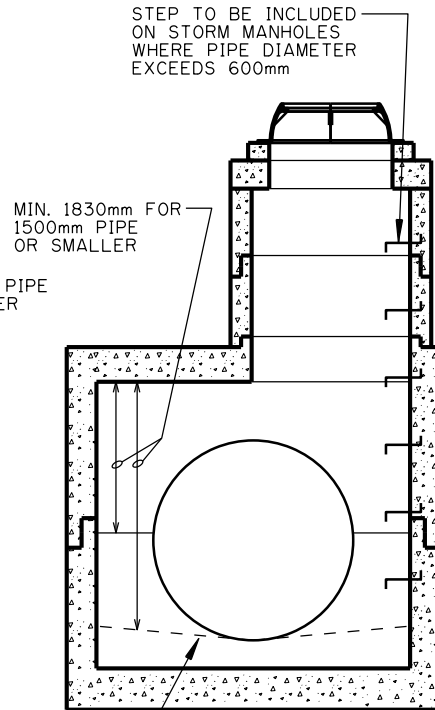

SECTION 'B-B'

DIMENSIONS ARE IN MILLIMETRES UNLESS OTHERWISE NOTED

No.	Date	Revision	App'd
3	2020/02/10	REVISED NOTE	M.C.
2	2015/12/08	NOTE FOR DEEP (SANITARY) MH COVER SIZE	
1	2005/10/07	PREVIOUS SHEETS #11 & #18 COMBINED / SPIGOT UP	

Date: 1999/09/14
 Scale: N.T.S.
 Approved by: *[Signature]*
 for The City of Calgary

SEWER CONSTRUCTION

PRECAST TYPE '1-S' MANHOLE & ASSEMBLY

Sheet **18**
 File Number 452.1001.008

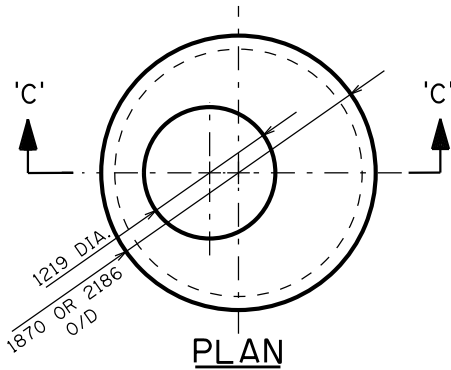

PLAN

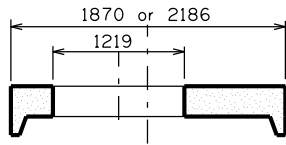

SECTION 'C-C'
SLAB TOP 1500 & 1800

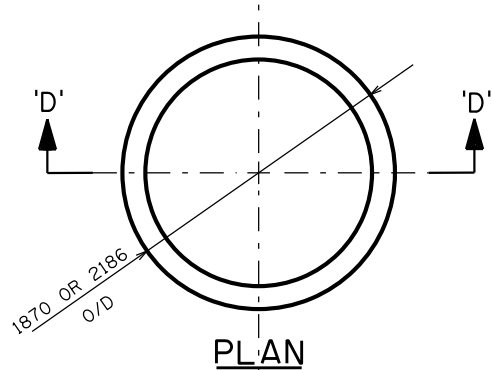

PLAN

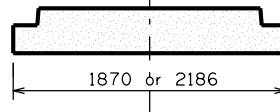

SECTION 'D-D'
BASE 1500 & 1800

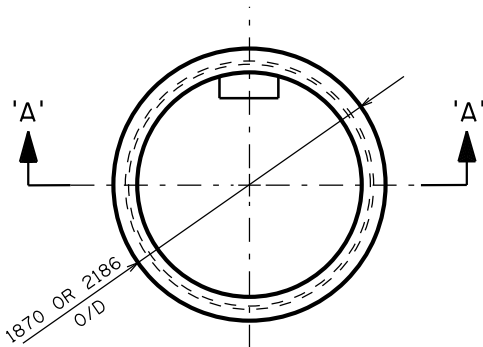

SECTION 'B-B'

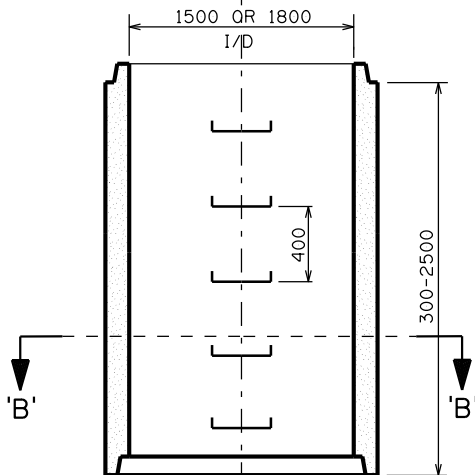

SECTION 'A-A'
MANHOLE

MATERIAL SPECIFICATIONS:

(ALL SPECIFICATIONS & STANDARDS REFER TO LATEST EDITION)

1. MANUFACTURED TO ASTM C478 & CSA 257.4
 2. CEMENT: SULPHATE RESISTANT TYPE: TYPE HS (TYPE 50) TO CSA A3001 OR TYPE V TO ASTM C150
 3. CONCRETE COMPRESSIVE STRENGTH : 35MPa @ 28 DAYS
 4. CONCRETE COVER = 25mm MIN
 5. AIR CONTENT: 4 TO 7% EXCEPT WHERE NO-SLUMP CONCRETE IS USED
 6. REINFORCING STEEL: DEFORMED BARS TO CSA G30.18, $f_y=400$ MPa
 7. STEPS AS PER STD. DWG. SHEET #9 (452.1001.021) SPACED AT 400mm.
- FOR MAXIMUM PIPE PROTRUSION SEE SHEET 18B (452.1001.040)
 - FOR MAXIMUM CONCRETE PIPE SIZES SEE SHEET 18C (452.1001.041)
- ⚠ - WATER RESOURCES RESERVES THE RIGHT TO REJECT ANY INSTALLATION.
- ⚠
⚠
⚠
⚠ - FOR SANITARY MANHOLES (8.0m OR DEEPER), 1500mm BARRELS ARE REQUIRED TO EXTEND TO SURFACE. LID AND COVER SHALL BE AS PER STANDARD DRAWING SHEET #1B

DIMENSIONS ARE IN MILLIMETRES UNLESS OTHERWISE NOTED

No.	Date	Revision
4	2020/02/10	MODIFIED NOTE
3	2018/03/13	MODIFIED NOTE
2	2015/12/08	NOTE ADDED FOR DEEP (SANITARY) MH COVER SIZE
1	2006/10/01	WASTEWATER CHANGED TO WATER RESOURCES

Date
2005/10/05

Scale
N.T.S.

Approved by
[Signature]

for The City of Calgary

SEWER CONSTRUCTION

LARGE DIAMETER MANHOLES
1500 & 1800

Sheet
18A

File Number
452.1001.043

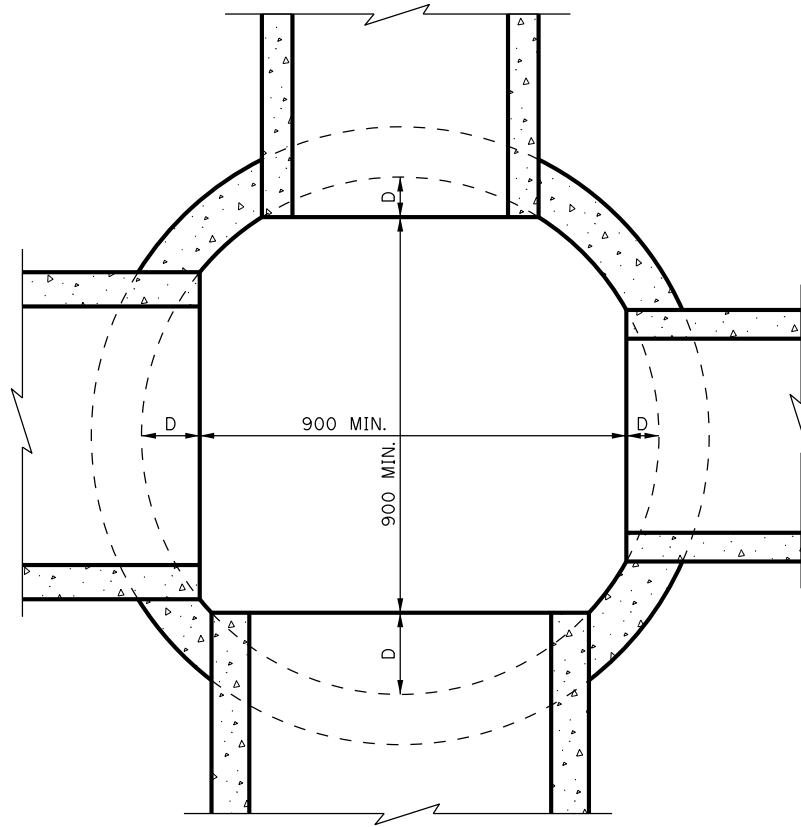

NOMINAL MANHOLE DIAMETER	MAXIMUM PIPE PROTRUSION 'D' (mm) FOR PIPE DIAMETER												
	Ø450	Ø525	Ø600	Ø675	Ø750	Ø900	Ø1050	Ø1200	Ø1350	Ø1500	Ø1650	Ø1800	Ø1950
1500	60	88	113	143	178								
1800	49	72	92	116	142	206	289						
2400	37	53	67	84	102	146	199	262	323	434			
3000	29	42	53	66	81	114	154	200	243	319	393	481	585

2

NOTES:

- 1. ALL DIMENSIONS ARE FOR CONCRETE PIPE ONLY.
- 2. ALL DIMENSIONS ARE NOMINAL DIAMETERS FOR PRECAST CONCRETE PIPES AND MANHOLES.
- 3. THE PIPE SHALL BE FLUSH WITH THE INSIDE MANHOLE WALL AT THE SPRINGLINE. PIPE PROTRUSIONS AT INVERT AND OBVERT SHALL BE MORTARED SMOOTHLY TO AVOID GAPS AND CRACKS, AND TO PROVIDE WATER TIGHTNESS. IT IS RECOMMENDED THAT THE MORTAR BE APPLIED AT APPROXIMATELY 45° TO 75° TO THE PROTRUDED PIPE.
- 4. THERE SHALL BE A MINIMUM 900mm CLEAR SPACE BETWEEN THE PROTRUSIONS TO PROVIDE ACCESS FOR MAINTENANCE PURPOSES.
- 5. WATER RESOURCES RESERVES THE RIGHT TO REJECT ANY INSTALLATION.

DIMENSIONS ARE IN MILLIMETRES UNLESS OTHERWISE NOTED

No.	Date	Revision
2	2020/02/07	REVISED TABLE AND NOTES
1	2006/10/01	WASTEWATER CHANGED TO WATER RESOURCES

Date
2005/09/26

Scale
N.T.S.

Approved by
[Signature]

App'd for The City of Calgary

SEWER CONSTRUCTION

MAXIMUM CONCRETE PIPE PROTRUSION SIZES IN LARGE DIAMETER ROUND MANHOLES

Sheet
18B

File Number
452.1001.040

**STRAIGHT THROUGH
(2-WAY JUNCTION)**

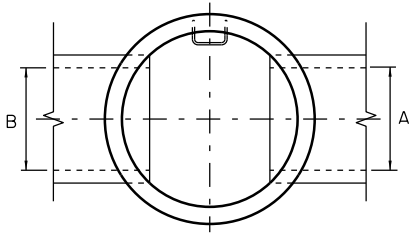

**RIGHT-ANGLED 2-WAY
JUNCTION 90°**

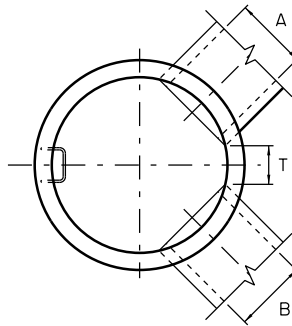

2-WAY JUNCTION 120°

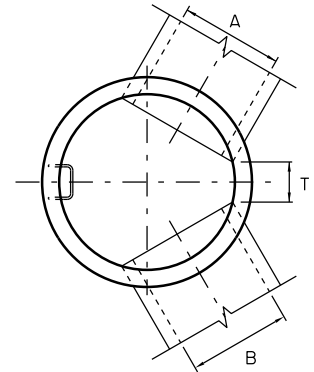

3-WAY JUNCTION 90°

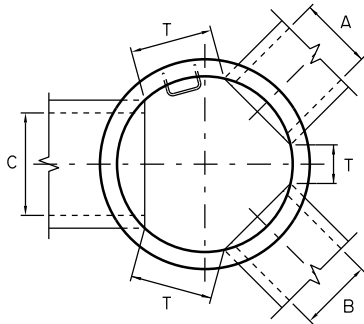

4-WAY JUNCTION

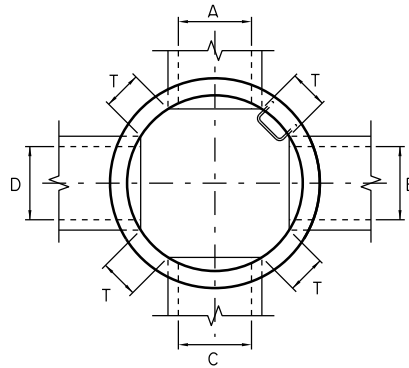

NOMINAL MANHOLE DIAMETER	MIN. "T"	MAXIMUM NOMINAL CONCRETE PIPE DIAMETER								
		STRAIGHT THROUGH (2-WAY JUNCTION)		RIGHT-ANGLED 2-WAY JUNCTION 90°		2-WAY JUNCTION 120°		3-WAY JUNCTION 90°		4-WAY JUNCTION
		A	B	A	B	A	B	A, B	C	A, B, C, D
1200	200	600	600	450	450	600	600	450	600	450
1500	300	900	900	600	600	750	750	525	900	525
1800	300	1050	1050	750	750	1050	1050	750	1050	750
*2400	300	1650	1650	1050	1050	1350	1350	1050	1650	1050
*3000	300	1950	1950	1500	1500	1800	1800	1500	1950	1500

NOMINAL MANHOLE DIAMETER	MIN. "T"	MAXIMUM NOMINAL PLASTIC PIPE DIAMETER (WITH CAST IN GASKET)								
		STRAIGHT THROUGH (2-WAY JUNCTION)		RIGHT-ANGLED 2-WAY JUNCTION 90°		2-WAY JUNCTION 120°		3-WAY JUNCTION 90°		4-WAY JUNCTION
		A	B	A	B	A	B	A, B	C	A, B, C, D
1200	200	600	600	450	450	600	600	450	600	450
1500	300	900	900	600	600	750	750	600	900	600
1800	300	1050	1050	750	750	1050	1050	750	1050	750
*2400	300	1500	1500	1050	1050	1200	1200	1050	1500	1050
*3000	300	1500	1500	1200	1200	1500	1500	1500	1500	1200

⚠ DRAWINGS ARE GUIDELINES ONLY. DISCUSS WITH MANHOLE MANUFACTURER FOR AVAILABLE OPTIONS AND ALTERNATIVES.

NOTES:

- 1. WATER RESOURCES RESERVES THE RIGHT TO REJECT ANY INSTALLATION.
- 2. "T" IS THE INSIDE DISTANCE BETWEEN THE OUTSIDE DIAMETER OF HOLES IN THE MANHOLE WALL.
- 3. WHEN CORING AN EXISTING MANHOLE, ALLOWABLE PIPE DIAMETER MAY BE SMALLER THAN SHOWN.
- * SUBMISSION OF DRAWINGS STAMPED AND SIGNED BY A PROFESSIONAL ENGINEER ARE REQUIRED PRIOR TO INSTALLATION.

DIMENSIONS ARE IN MILLIMETRES UNLESS OTHERWISE NOTED

No.	Date	Revision
3	2020/02/10	REVISED & ADDED NOTES
2	2017/12/13	EDITED CON. PIPE TBL. ADDED PLASTIC PIPE TBL. EDITED NOTES
1	2006/10/01	REVISED TEXT

Date
2005/09/26
Scale
N.T.S.
Approved by
[Signature]
for The City of Calgary

SEWER CONSTRUCTION
**MAXIMUM PIPE SIZES
IN ROUND MANHOLES**

Sheet
18C
File Number
452.1001.041

NOTES:

1. CHANNEL WIDTH REQUIREMENT AS PER BENCHING DETAIL - SHEET #39 (452.1003.007).
2. THIS MANHOLE TO BE CONSTRUCTED ON 100, 150, 200, 250, 300mm CONNECTIONS.
3. PROVIDE A MINIMUM OF 150mm TO A MAXIMUM OF 610mm DROP FROM THE INCOMING PIPE TO THE INVERT OF THE PRE-BENCHED CHANNEL.
4. ALTERNATES SHALL NOT BE USED WITHOUT PRIOR APPROVAL FROM THE WATER RESOURCES MANAGER INFRASTRUCTURE PLANNING.
5. DEADEND PRE-BENCHED MANHOLES ACCEPTABLE. ENSURE SIMILAR CONFIGURATION.

MATERIAL SPECIFICATIONS:

(ALL SPECIFICATIONS & STANDARDS REFER TO LATEST EDITION)

1. CEMENT: SULFATE RESISTANT TYPE: TYPE HS (TYPE 50) TO CSA A3001 OR TYPE V TO ASTM C150.
2. CONCRETE COMPRESSIVE STRENGTH: 35 MPa AT 28 DAYS.
3. AIR CONTENT: 4% TO 7% EXCEPT WHERE NO-SLUMP CONCRETE IS USED.

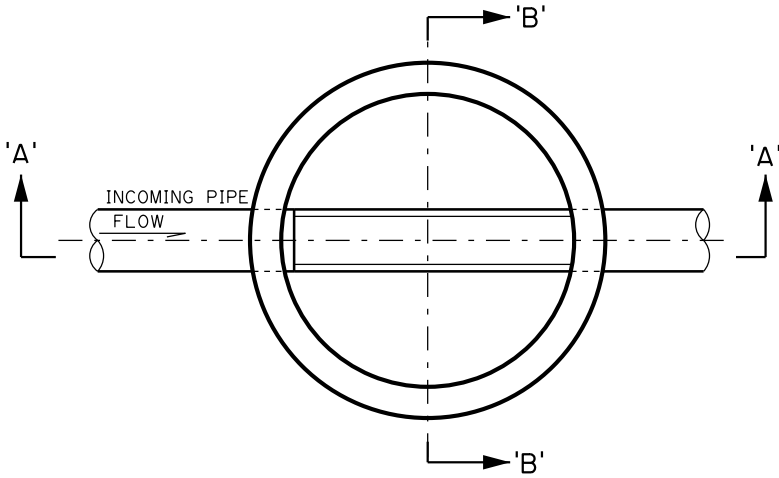

PLAN

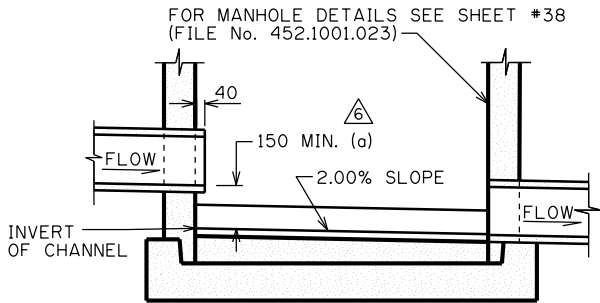

- a) MINIMUM DROP FROM INLET TO CHANNEL INVERT IS 150mm
MINIMUM DROP FROM INLET TO OUTLET IS 175mm
MAXIMUM DROP FROM INLET TO OUTLET IS 610mm
- b) 50mm ON EXISTING SERVICE LEADS

SECTION 'A-A'

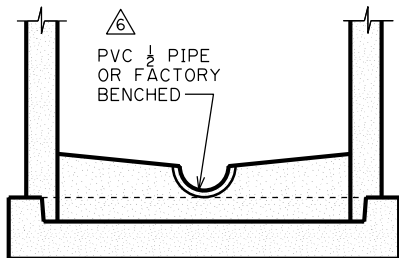

SECTION 'B-B'

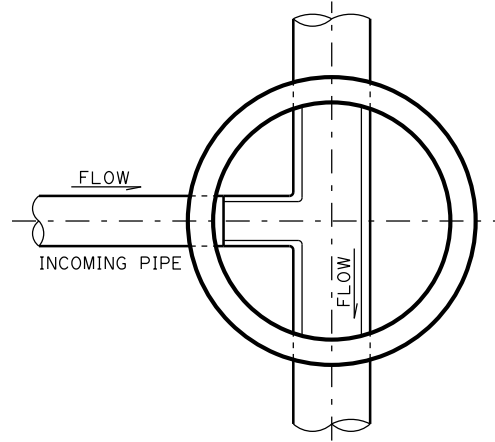

ALTERNATE
(SEE NOTE 4)

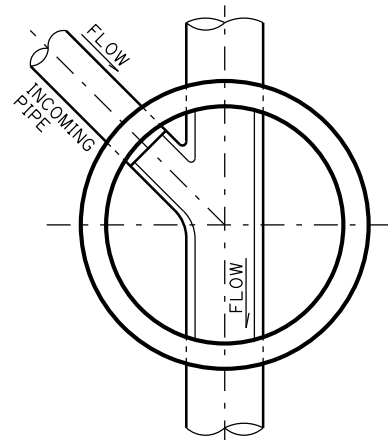

ALTERNATE
(SEE NOTE 4)

DIMENSIONS ARE IN MILLIMETRES UNLESS OTHERWISE NOTED

7	2020/06/01	REVISED NOTES	D.N.
6	2019/12/16	REVISED NOTES	M.C.
5	2009/11/01	ADDITION TO NOTE 3	
4	2008/07/01	SECTION 'A-A' DELETED. TEXT 150mm TO 175mm	
3	2007/01/23	REVISED NOTES 2 & 5	
2	2006/10/01	REVISED TEXT	
No.	Date	Revision	App'd

Date: 1998/02/05
Scale: N.T.S.
Approved by: *[Signature]*
for the City of Calgary

SEWER CONSTRUCTION
CONTROL MANHOLE
(TEST MANHOLE)

Sheet **19**
File Number 452.1001.015

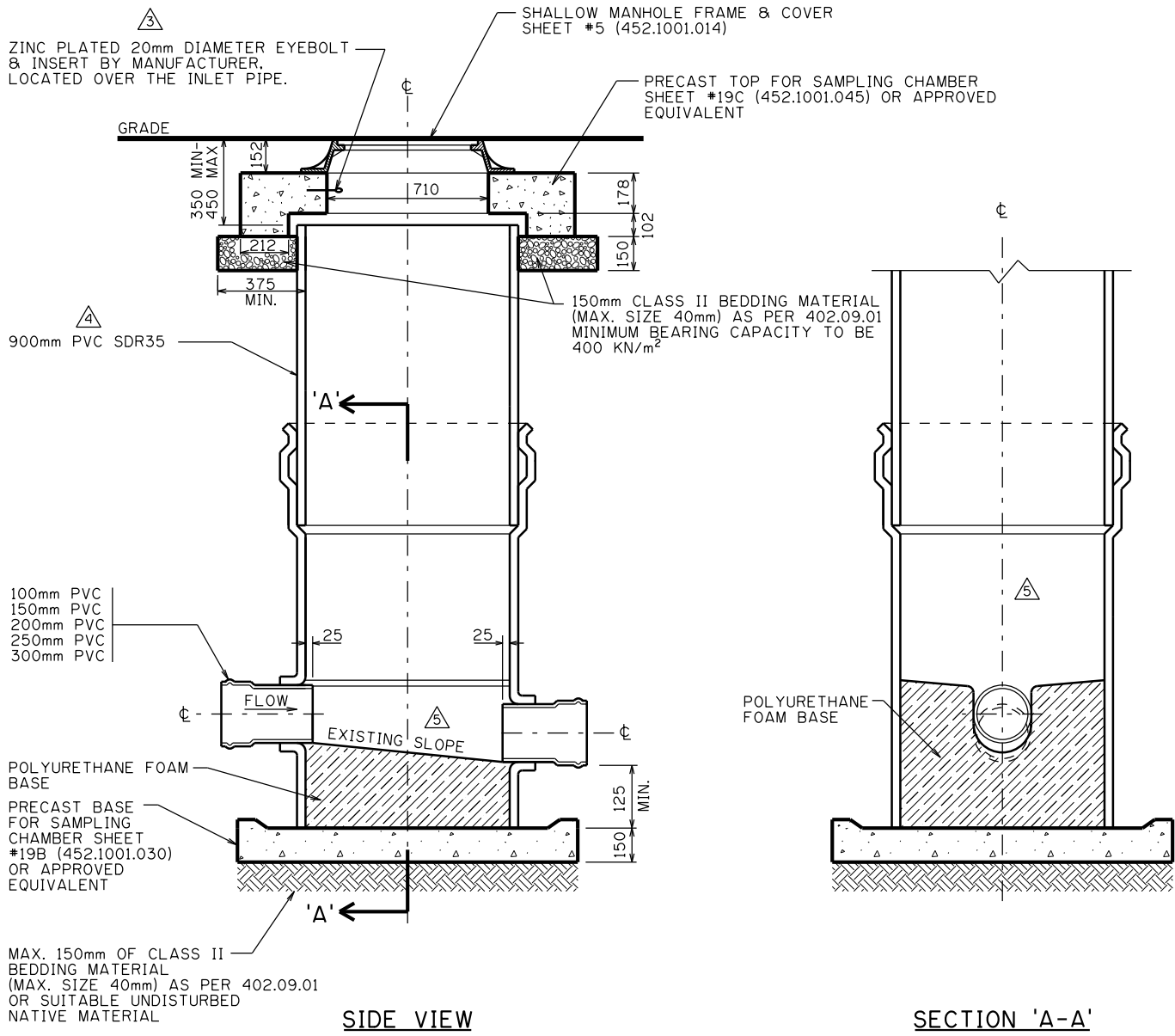

NOTE:

1. STRICTLY FOR RETROFIT INSTALLATIONS ONLY
2. PRIOR APPROVAL FROM WATER RESOURCES REQUIRED

DIMENSIONS ARE IN MILLIMETRES UNLESS OTHERWISE NOTED

No.	Date	Revision	App'd	Date	Scale	Approved by	Sheet
5	2017/08/17	REVISED DIAGRAM & NOTES	MC	1994/01/01	N.T.S		19A
4	2009/12/01	REMOVED "OR SDR41" FROM NOTE					
3	2008/10/01	CHANGE EYEBOLT SIZE					
2	2007/11/01	CHANGE CHAMBER SIZE (900) & COLLAR, TAKE OUT SLIDING GATE					
1	2004/11/01						
				Date		Scale	
				1994/01/01		N.T.S	
				Approved by			
				for The City of Calgary		Sheet	
						19A	
						File Number	
						452.1001.029	

SEWER CONSTRUCTION

SAMPLING CHAMBER

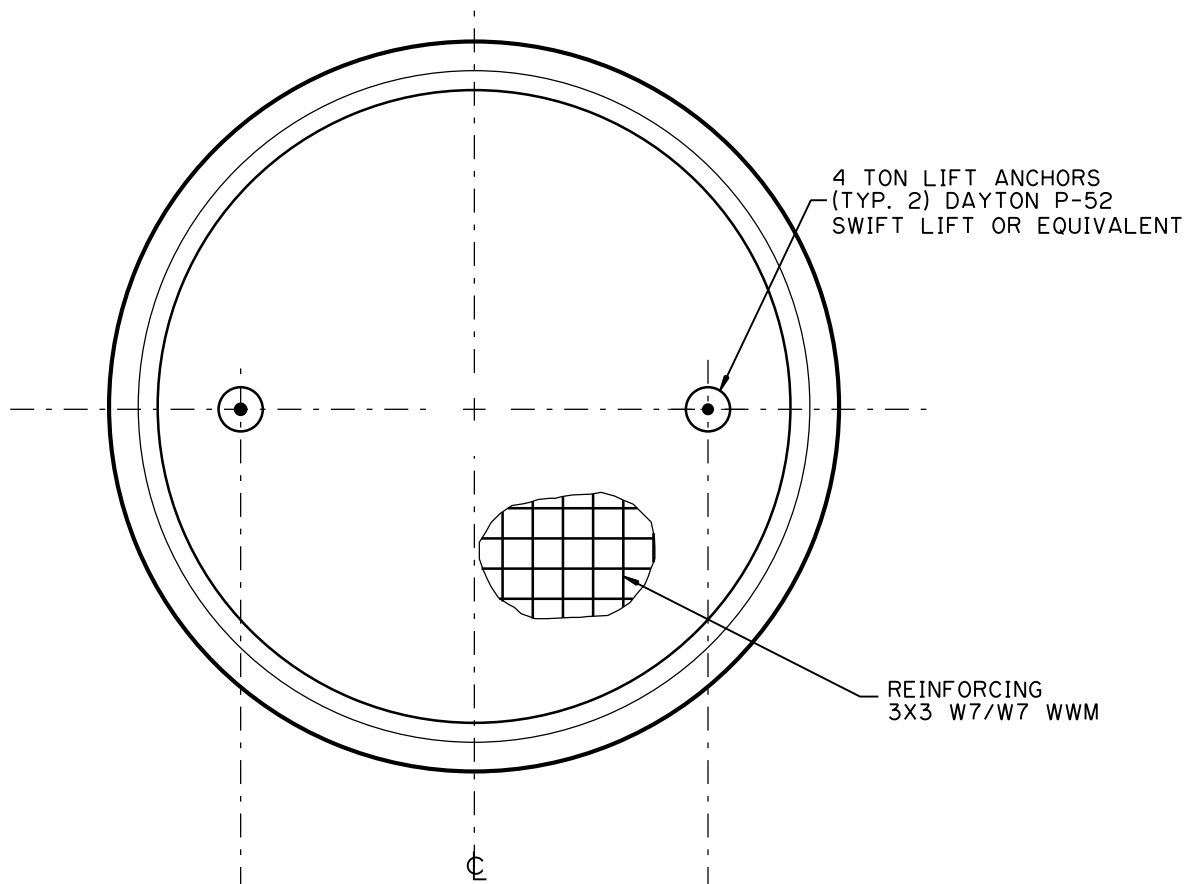

PLAN

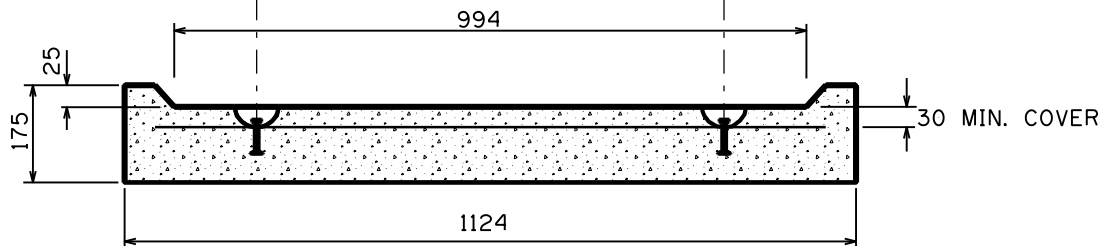

SECTION

MATERIAL SPECIFICATIONS:

(ALL SPECIFICATIONS & STANDARDS REFER TO LATEST EDITION)

1. PRODUCED IN ACCORDANCE WITH ASTM C478
2. DESIGNED FOR WEIGHT OF PVC TEST MH
3. TYPE HS CEMENT TO CSA A3001 OR TYPE V TO ASTM C150
4. CONCRETE STRENGTH $f_c=35MPa$ AT 28 DAYS
5. AIR CONTENT = 4% TO 7% EXCEPT WHERE NO-SLUMP CONCRETE IS USED
6. MINIMUM CONCRETE COVER OVER REINFORCING = 30mm
7. WELDED WIRE FABRIC TO CAN/CSA G30.15, MIN. YIELD STRENGTH, $f_y=450MPa$

DIMENSIONS ARE IN MILLIMETRES UNLESS OTHERWISE NOTED

No.	Date	Revision
3	2020/02/10	CONCRETE STRENGTH REVISED
2	2007/11/01	CHANGE OF SIZE SHAPE & REINFORCEMENT
1	2004/11/01	MATERIAL SPECIFICATIONS REVISED

Date
1999/09/14

Scale
N.T.S.

Approved by
[Signature]

for the City of Calgary

SEWER CONSTRUCTION

PRECAST BASE FOR SAMPLING CHAMBER

Sheet
19B

File Number
452.1001.030

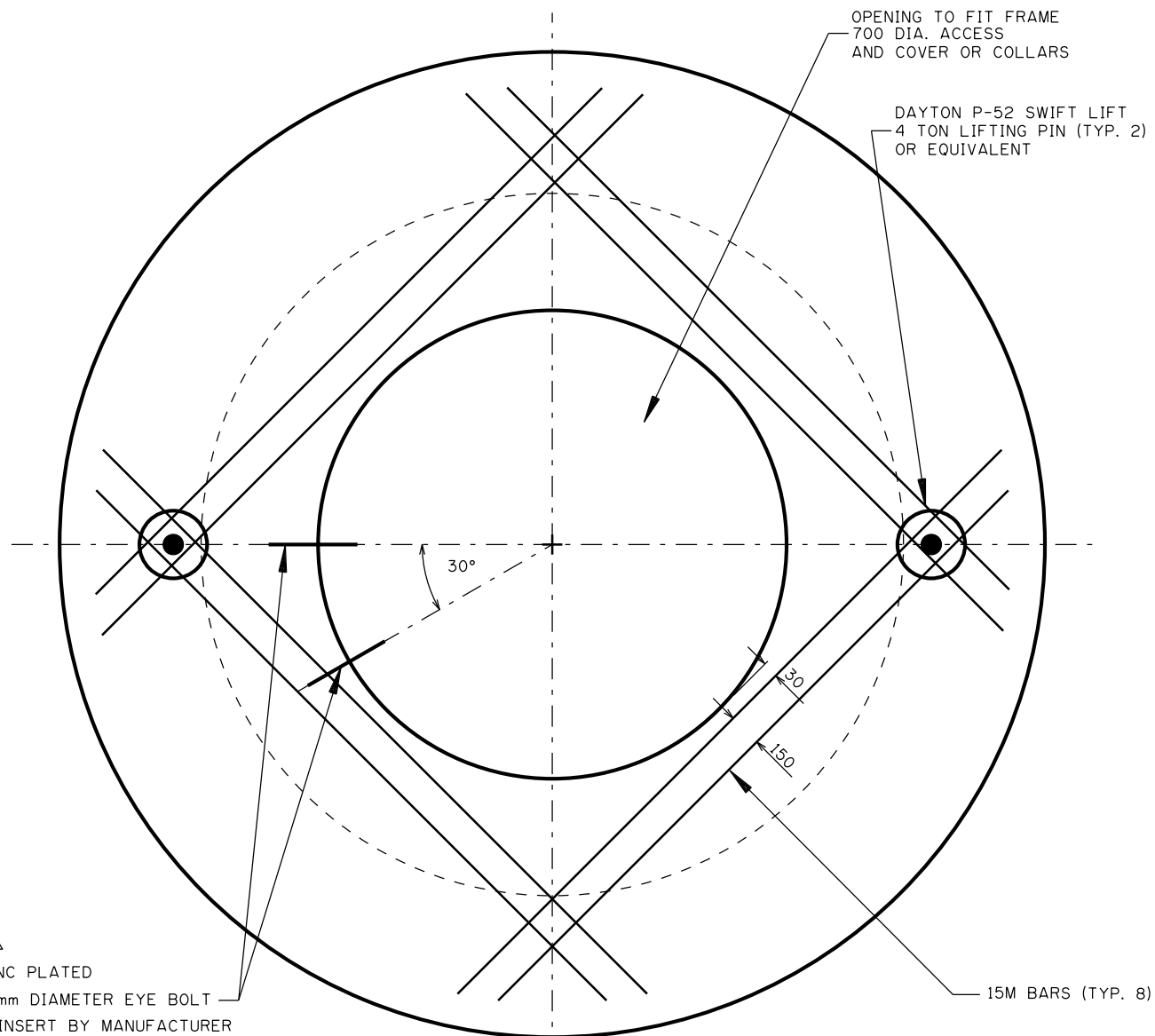

PLAN

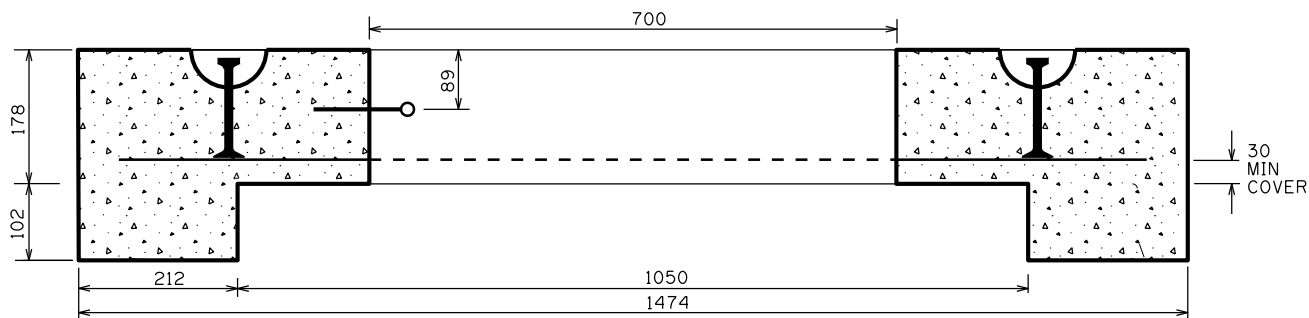

SECTION VIEW

MATERIAL SPECIFICATIONS:

(ALL SPECIFICATIONS & STANDARDS REFER TO LATEST EDITION)

1. MANUFACTURED TO ASTM C478
2. DESIGNED FOR HEAVIEST WHEEL OF CL-800 LOADING
3. TYPE HS CEMENT TO CSA A3001 OR TYPE V TO ASTM C150
4. CONCRETE STRENGTH: $f_c = 35\text{MPa}$ @ 28 DAYS
5. AIR CONTENT: 4% TO 7% EXCEPT WHERE NO-SLUMP CONCRETE IS USED
6. MINIMUM CONCRETE COVER OVER REINFORCING = 30mm
7. REINFORCING BARS TO CAN/CSA G30.18 GRADE 400W
8. MINIMUM SOIL BEARING CAPACITY UNDER 212mm WIDE BASE TO BE 400 KN/m^2 , OWNER OR CONTRACTOR TO CONFIRM



DIMENSIONS ARE IN MILLIMETRES UNLESS OTHERWISE NOTED

No.	Date	Revision
2	2020/02/07	CONCRETE STRENGTH REVISED
1	2008/10/16	CHANGE EYE BOLT DIAMETER

Date
2007/11/01

Scale
N.T.S.

Approved by
J.M. [Signature]

for The City of Calgary

SEWER CONSTRUCTION

SLAB TOP FOR SAMPLING CHAMBER

Sheet
19C

File Number
452.1001.045

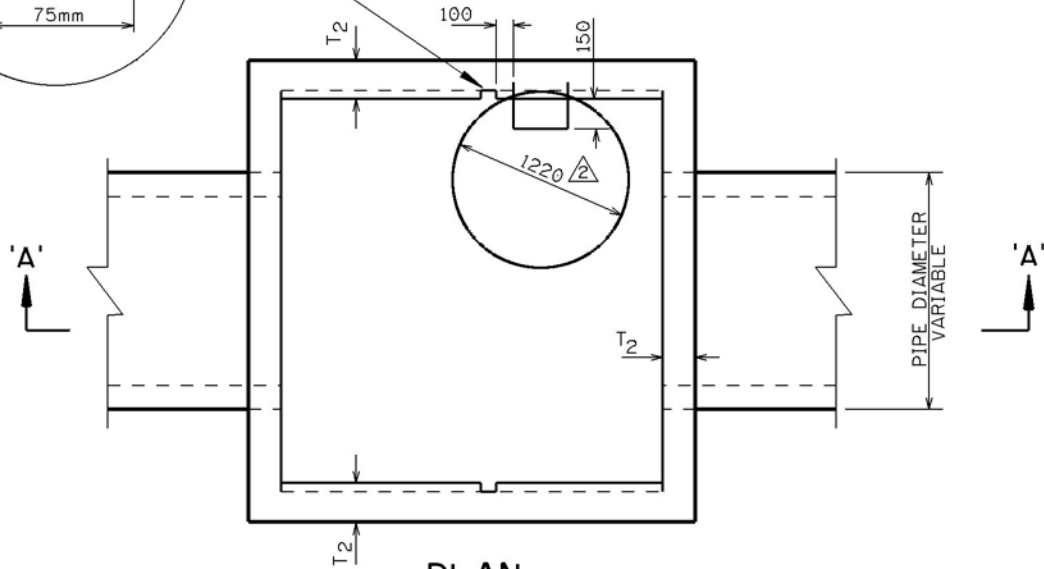
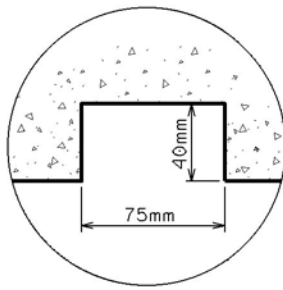

PLAN

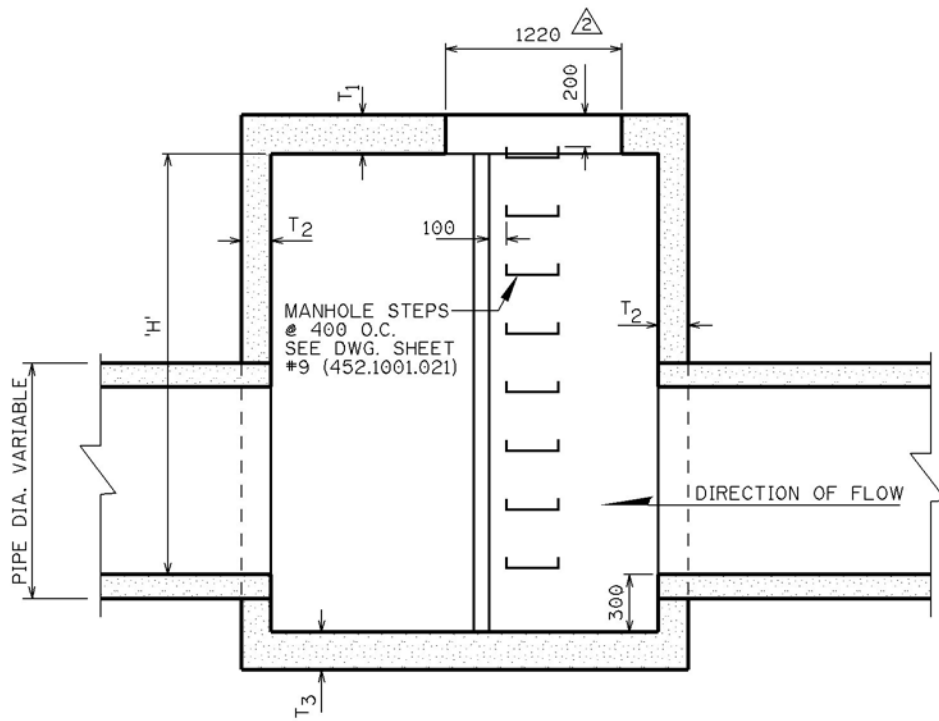

SECTION 'A-A'

NOTES:

- 'H' SHALL BE 2000mm FOR PIPE DIAMETER 1800mm AND SMALLER.
- 'H' SHALL BE 230mm PLUS THE OUTSIDE DIAMETER OF THE PIPE FOR PIPE DIAMETER GREATER THAN 1800mm.
- TOP STEP SHALL BE POSITIONED 400mm BELOW BOTTOM STEP IN MANHOLE RISER.
- DISTANCE BETWEEN BOTTOM STEP AND FLOOR NOT TO EXCEED 400mm.
- CITY TO INSTALL STOP LOG AT LATER DATE.

MATERIAL SPECIFICATION:

MATERIAL SPECIFICATIONS REINFORCEMENT AND DIMENSIONS SAME AS TYPE "1" MANHOLE BASE. SEE SHEET NO. 17 (452.1001.002).

DIMENSIONS ARE IN MILLIMETRES UNLESS OTHERWISE NOTED

No.	Date	Revision	App'd
2	2014/03/01	CHANGED MANHOLE SIZE	
1	2004/11/01	NOTES CHANGED	

Date
1999/09/14
Scale
N.T.S.
Approved by
AS
for The City of Calgary

SEWER CONSTRUCTION
SKIMMING MANHOLE BASE

Sheet
20
File Number
452.1001.024

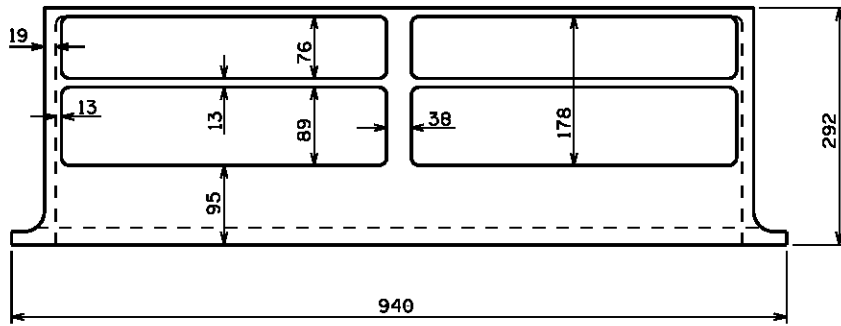

FRONT VIEW

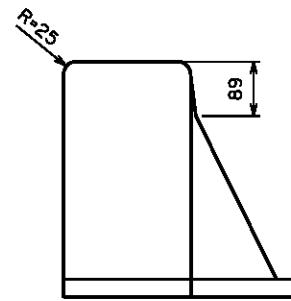

END VIEW

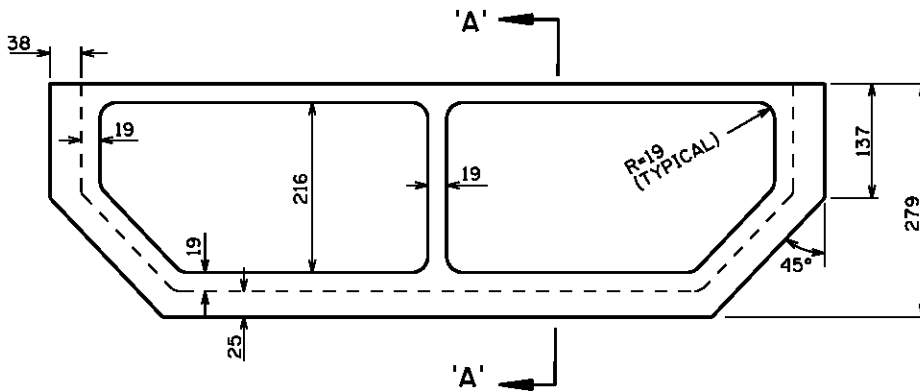

BOTTOM VIEW

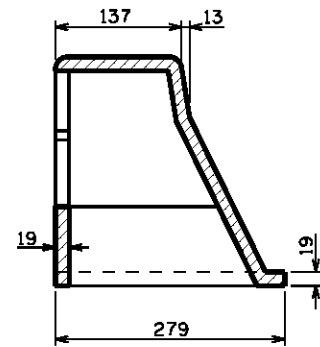

SECTION 'A-A'

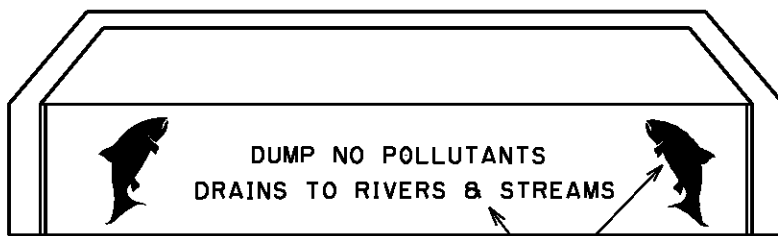

TOP VIEW

LETTERS AND FISH PROFILES RAISE 3.0mm ABOVE SURFACE.

△ SIDE INLET (C):

GRATE OPEN AREA (FRONT) = 0.124m²
 GRATE OPEN AREA (BOTTOM) = 0.159m²

ASSEMBLY:

1. SINGLE C - ONE SIDE INLET PLUS ONE TYPE "C" GRATE
2. TWIN C - TWO SIDE INLETS PLUS TWO TYPE "C" GRATES

NOTE:

- △** TWO PIECE CATCH BASIN SIDE INLET TYPE 'C' (SHEET 21A - FILE #452.1002.038) REQUIRED ON ALL FREEWAYS, MAJOR ROADS, COLLECTOR ROADS, BUS ROUTES AND ON ANY ROAD WHERE SNOW CLEARING OCCURS.

MATERIAL SPECIFICATIONS:

- DUCTILE IRON TO CONFORM TO A.S.T.M. A536 (LATEST EDITION), GRADE 80-55-06
- MASS = 86 KILOGRAMS ±5%
- COATED CASTINGS ACCEPTED ONLY WHEN REQUIRED BY CITY.

DIMENSIONS ARE IN MILLIMETRES UNLESS OTHERWISE NOTED

5	2018/02/15	REVISED NOTES	MC	Date	1999/09/14		SEWER CONSTRUCTION	Sheet	21
4	2014/02/01	ASPHALT NOTE CHANGED		Scale	N.T.S.			Approved by 	
3	2010/04/01	NOTE ADDED TO MATERIAL SPECS & NOTE FOR TWO PIECE CB REQUIREMENTS		for The City of Calgary		CATCH BASIN SIDE INLET TYPE 'C'			
2	2009/04/01	ADDED AREA AND ASSEMBLY NOTES							
1	2001/11/20	ADDED TOP VIEW & CHANGED MATERIAL SPEC							
No.	Date	Revision	App'd						

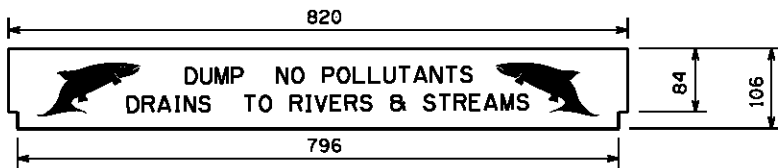

PART ① PLAN

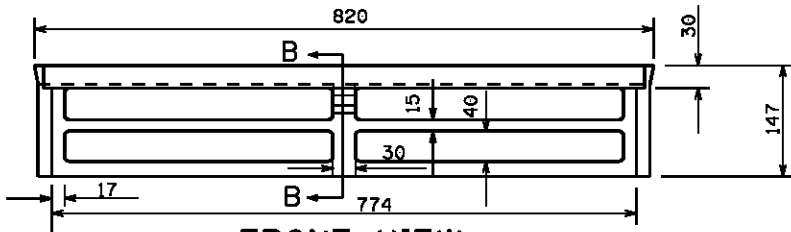

FRONT VIEW

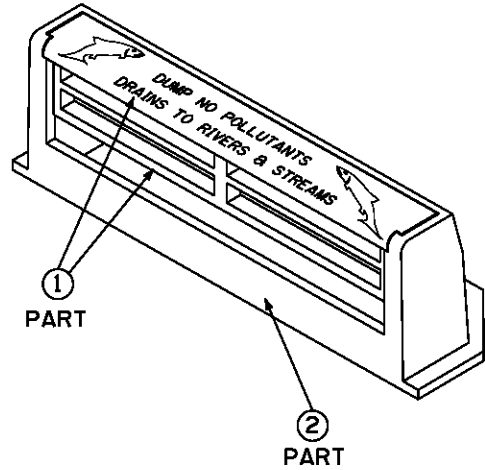

PART ①

PART ②

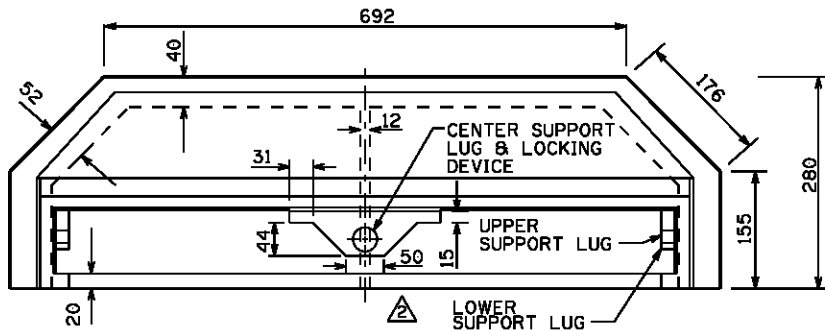

PART ② PLAN

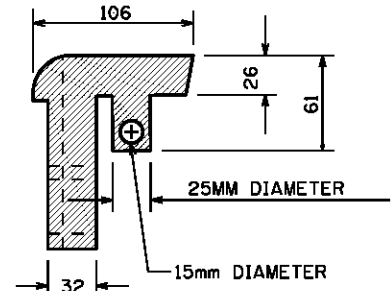

SECTION 'B-B'

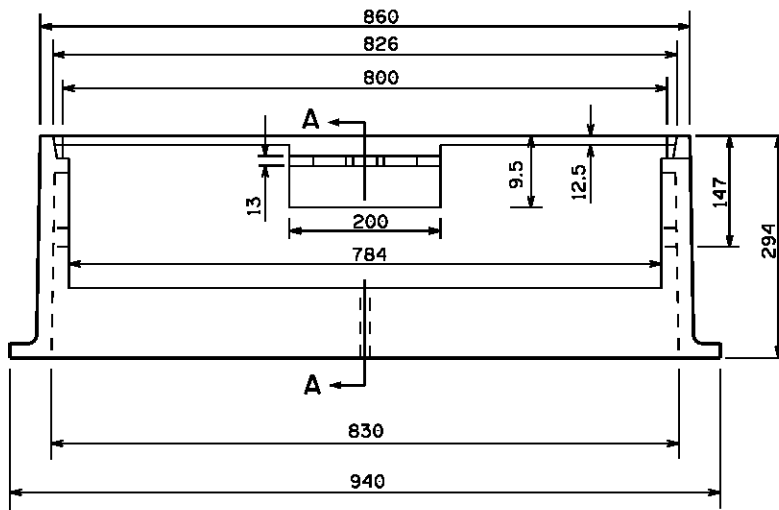

FRONT VIEW

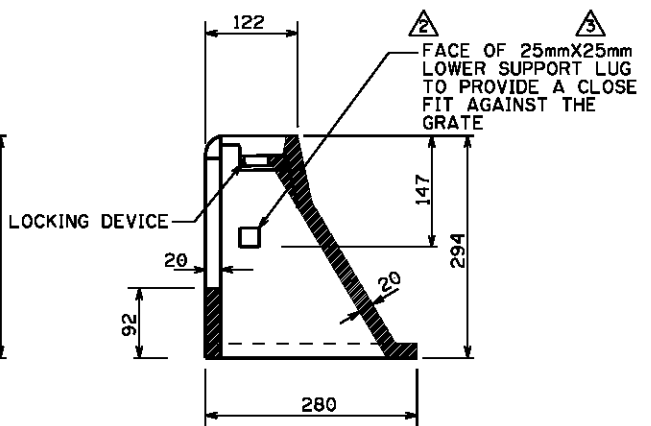

SECTION 'A-A'

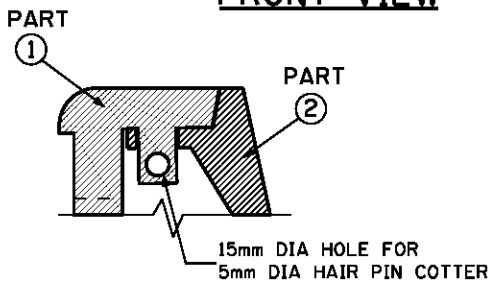

LOCKING DEVICE DETAIL

MATERIAL SPECIFICATIONS:

-DUCTILE IRON TO CONFORM TO A.S.T.M. A536 GRADE 80-55-06 (LATEST EDITION)

-COATED CASTINGS ACCEPTED ONLY WHEN REQUIRED BY CITY

TWO PIECE SIDE INLET (C):

-GRATE OPEN AREA (FRONT) = 0.103m²
-GRATE OPEN AREA (BOTTOM) = 0.159m²

NOTE:

1. REQUIRED ON ALL FREEWAYS, MAJOR ROADS, COLLECTOR ROADS AND BUS ROUTES.
2. REQUIRED ON ANY ROAD WHERE SNOW CLEARING OCCURS.

DIMENSIONS ARE IN MILLIMETRES UNLESS OTHERWISE NOTED

No.	Date	Revision
4	2018/02/15	REVISED NOTES
3	2013/08/30	ADDED NOTE #2 AND CHANGED NOTE
2	2013/06/28	ADDED LOWER SUPPORT LUG. CHANGED DIMENSION, CHANGED NOTE
1	2004/12/13	REVISED NOTE

Date	2004/09/01
Scale	N.T.S.
Approved by	
App'd for The City of Calgary	

SEWER CONSTRUCTION
TWO PIECE CATCH BASIN SIDE INLET TYPE 'C'

Sheet	21A
File Number	452.1002.039

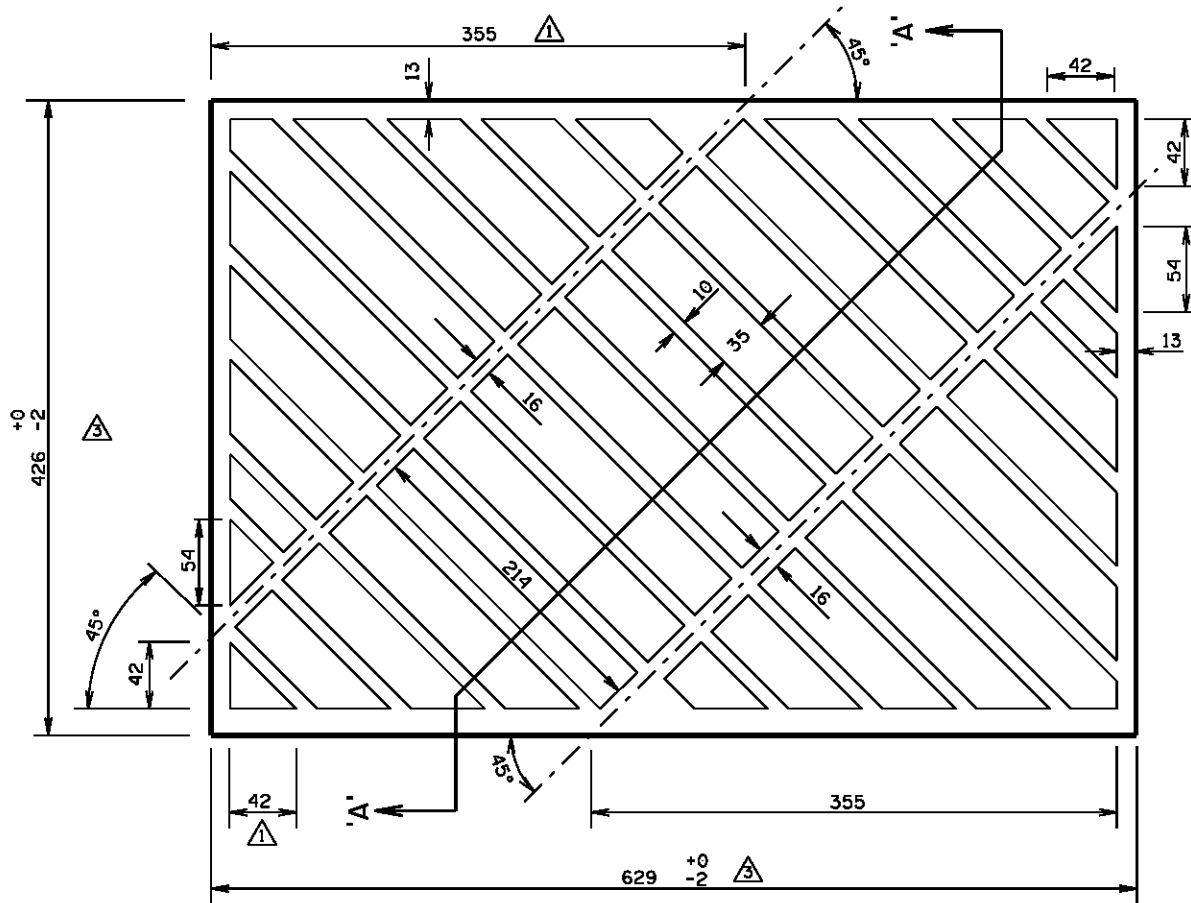

PLAN VIEW

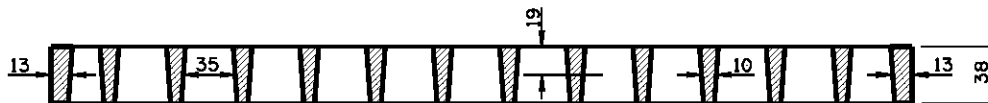

SECTION 'A-A'

NOTE:

TAPER ON BARS IS TO BE ±1mm FROM TOP TO BOTTOM.

GRATE (C) & (K-3):
 GRATE OPEN AREA = 0.1706m²

ASSEMBLY:

1. SINGLE C - ONE SIDE INLET PLUS ONE TYPE "C" GRATE
2. TWIN C - TWO SIDE INLETS PLUS TWO TYPE "C" GRATES
3. K-3 - ONE TYPE "C" GRATE

MATERIAL SPECIFICATIONS

- DUCTILE IRON TO CONFORM TO A.S.T.M. A536 GRADE 80-55-06 (LATEST EDITION)
- MASS = 24 KILOGRAMS ±5%

SA - COATED CASTINGS ACCEPTED ONLY WHEN REQUIRED BY CITY.

DIMENSIONS ARE IN MILLIMETRES UNLESS OTHERWISE NOTED

5	2018/02/15	REVISED NOTES	MC	Date 1998/07/05		SEWER CONSTRUCTION	Sheet 22
4	2014/02/05	ASPHALT SPEC MODIFIED		Scale N.T.S.			Approved by
3	2004/11/01	DIMENSIONS MODIFIED IN PLAN VIEW				File Number 452.1002.010	
2	2004/09/30	AREA AND ASSEMBLY NOTES ADDED					
1	2000/12/01	GENERAL REVISIONS					
No.	Date	Revision	App'd	for The City of Calgary			

LETTERS AND FISH PROFILES
RAISE 3.0mm ABOVE SURFACE

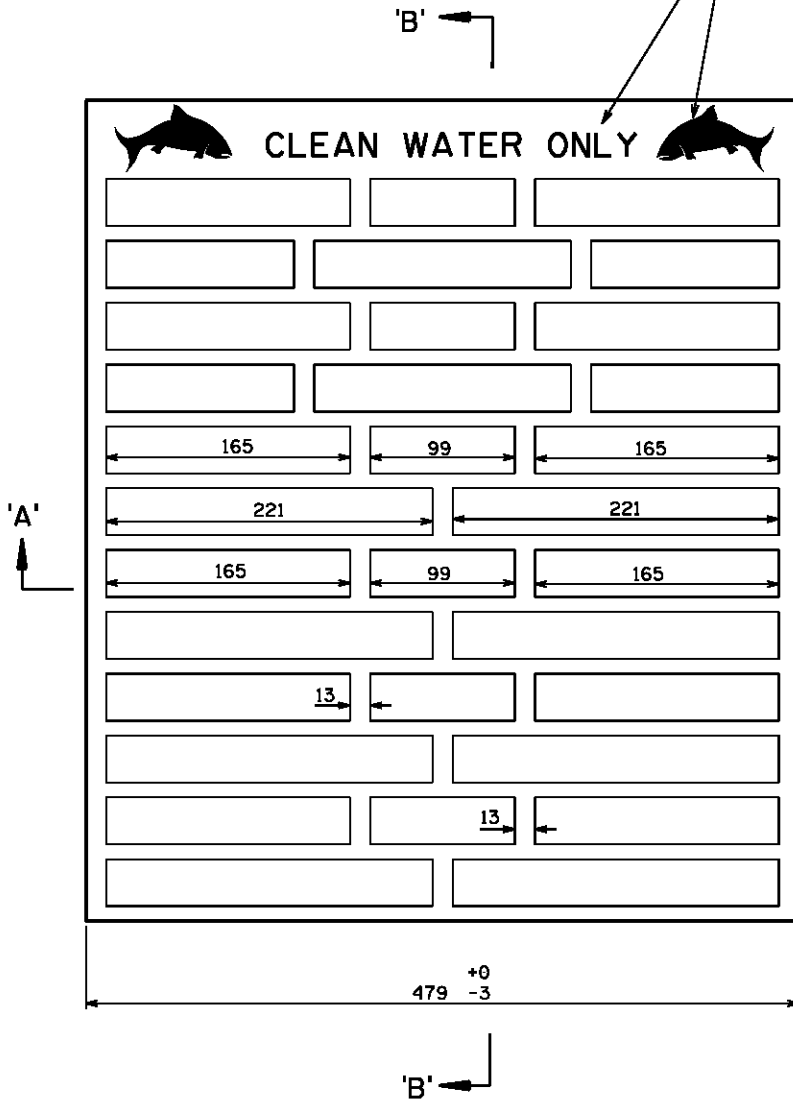

PLAN

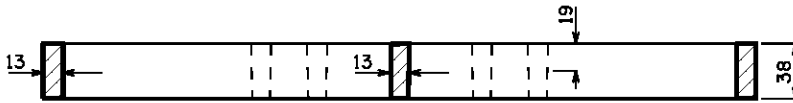

SECTION 'A-A'

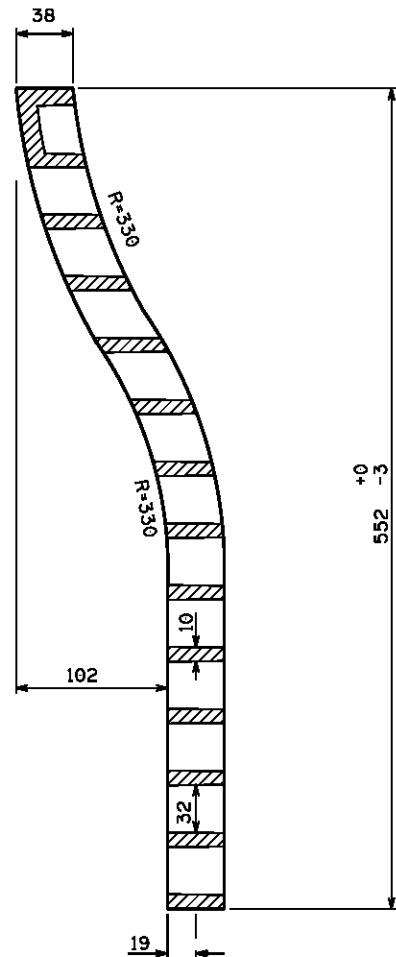

SECTION 'B-B'

MATERIAL SPECIFICATIONS:

- ⚠️ - DUCTILE IRON TO CONFORM TO A.S.T.M. A536 GRADE 80-55-06 (LATEST EDITION)
- MASS = 23 KILOGRAMS ±5%.
- ⚠️ - COATED CASTINGS ACCEPTED ONLY WHEN REQUIRED BY CITY

GRATE (K-2):

GRATE OPEN AREA = 0.1664m²

⚠️ **ASSEMBLY:**

- 1. K-2 - TWO TYPE "K-2" GRATES

DIMENSIONS ARE IN MILLIMETRES
UNLESS OTHERWISE NOTED

		Date	1999/09/14		SEWER CONSTRUCTION	Sheet 23
		Scale	N.T.S.			
4	2018/02/15	REVISED NOTES	MC	Approved by for The City of Calgary	CATCH BASIN GRATE TYPE 'K-2'	File Number 452.1002.015
3	2014/02/05	ASPHALT COATING SPEC CHANGED				
2	2004/09/30	ADDED AREA ASSEMBLY & MAT. SPEC. NOTES				
1	2002/11/07	ADDED FISH LOGO				
No.	Date	Revision	App'd			

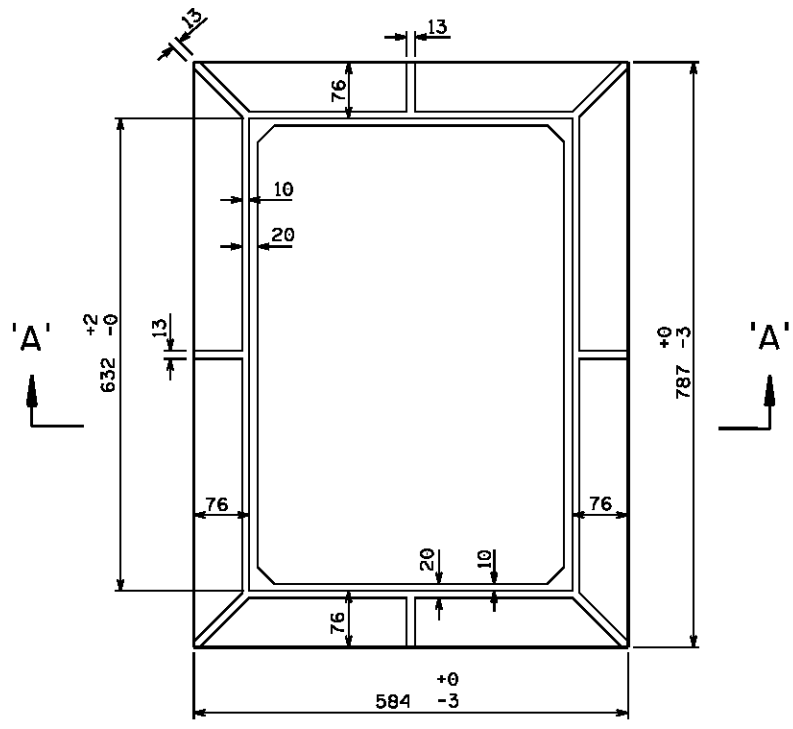

PLAN

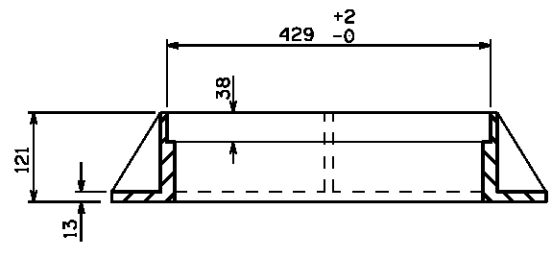

SECTION 'A-A'

MATERIAL SPECIFICATIONS:

- ⚠️ -GREY CAST IRON TO CONFORM TO A.S.T.M. A48 CLASS 35B (LATEST EDITION)
- MASS = 57 KILOGRAMS ± 5%
- ⚠️⚠️ -COATED CASTINGS ACCEPTED ONLY WHEN REQUIRED BY CITY.

DIMENSIONS ARE IN MILLIMETRES UNLESS OTHERWISE NOTED

				Date 1999/09/14 Scale N.T.S. Approved by  for The City of Calgary	SEWER CONSTRUCTION CATCH BASIN FRAME TYPE 'C'	Sheet 24 File Number 452.1002.003
2	2018/02/15	REVISED NOTES				
1	2014/02/05	REVISED NOTE				
No.	Date	Revision	App'd			

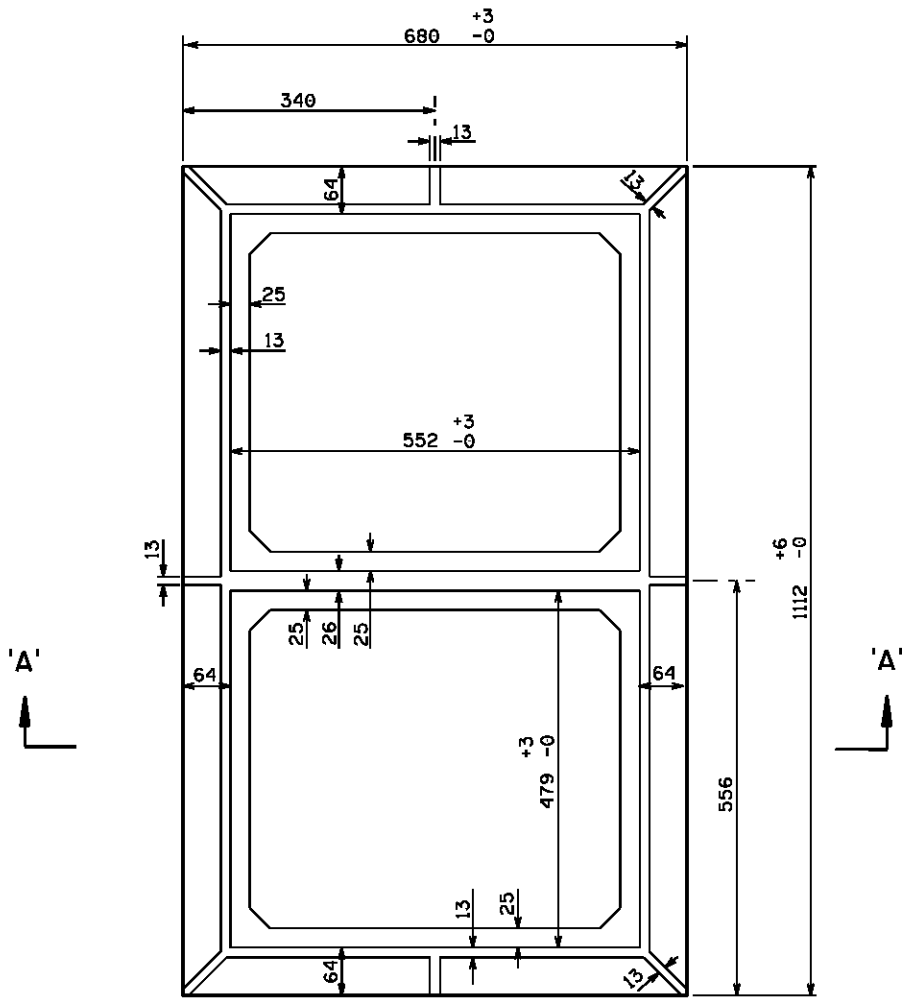

PLAN

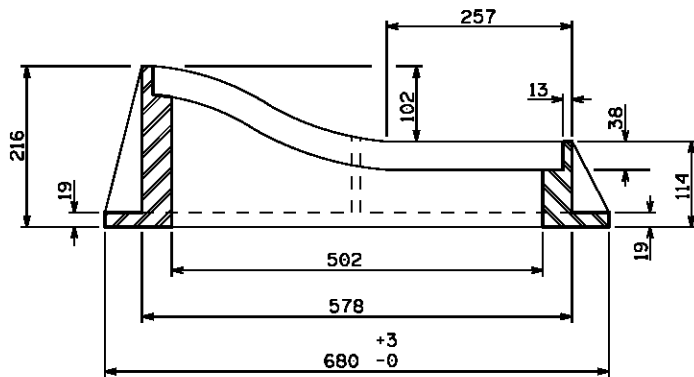

SECTION 'A-A'

MATERIAL SPECIFICATIONS:

- GREY CAST IRON TO CONFORM TO
 A.S.T.M. A48 CLASS 35B (LATEST EDITION)
 - MASS = 186 KILOGRAMS + 5%
- COATED CASTINGS ACCEPTED ONLY WHEN
 REQUIRED BY CITY.

DIMENSIONS ARE IN MILLIMETRES
UNLESS OTHERWISE NOTED

				Date 1999/09/14	 Calgary	SEWER CONSTRUCTION			Sheet 25
				Scale N.T.S.		CATCH BASIN FRAME TYPE 'K-2'			File Number
2	2018/02/15	REVISED NOTES		Approved by	 for The City of Calgary				452.1002.014
1	2014/02/05	ADDED NOTE TO MATERIAL SPECS.	MC						
No.	Date	Revision	App'd						

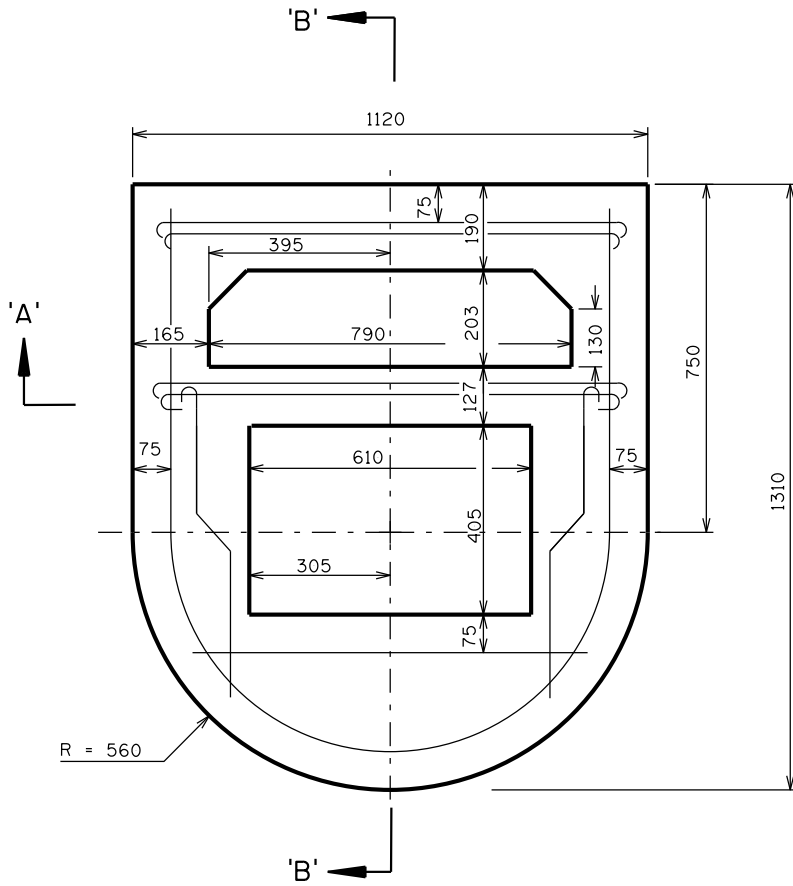

PLAN

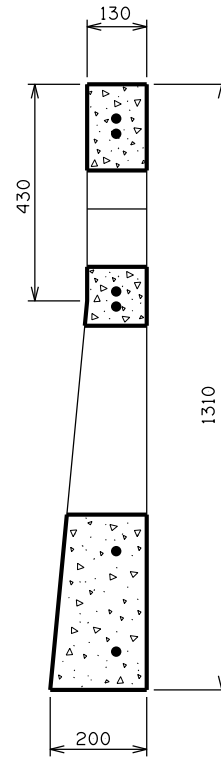

SECTION 'B-B'

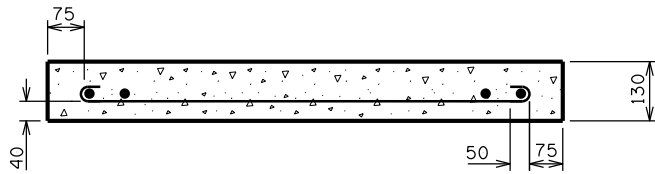

SECTION 'A-A'

MATERIAL SPECIFICATIONS:

(ALL SPECIFICATIONS & STANDARDS REFER TO LATEST EDITION)

1. CEMENT: SULPHATE RESISTANT TYPE: TYPE HS (TYPE 50) TO CSA A3001 OR TYPE V TO ASTM C150.
2. CONCRETE COMPRESSIVE STRENGTH: 35MPa AT 28 DAYS.
3. AIR CONTENT: 4% TO 7% EXCEPT WHERE NO-SLUMP CONCRETE IS USED.
4. CONCRETE CLEAR COVER: 30mm MIN.
5. REINFORCING STEEL: DEFORMED BARS TO CSA G30.18, $f_y = 400MPa$ TO BE 15M BARS WITH COLD BENDS, INSIDE RADIUS 30mm & SLANTED.

DIMENSIONS ARE IN MILLIMETRES
UNLESS OTHERWISE NOTED

No.	Date	Revision
3	2020/02/10	CONCRETE STRENGTH REVISED
2	2005/09/01	REINFORCEMENT REVISED
1	2004/11/01	REVISED MATERIAL SPECS./ REMOVE SUPPLIERS

Date
1999/09/14

Scale
N.T.S.

Approved by
[Signature]

App'd
for The City of Calgary

SEWER CONSTRUCTION

PRECAST TOP FOR
TYPE 'C' CATCH BASIN

Sheet
26

File Number
452.1002.001

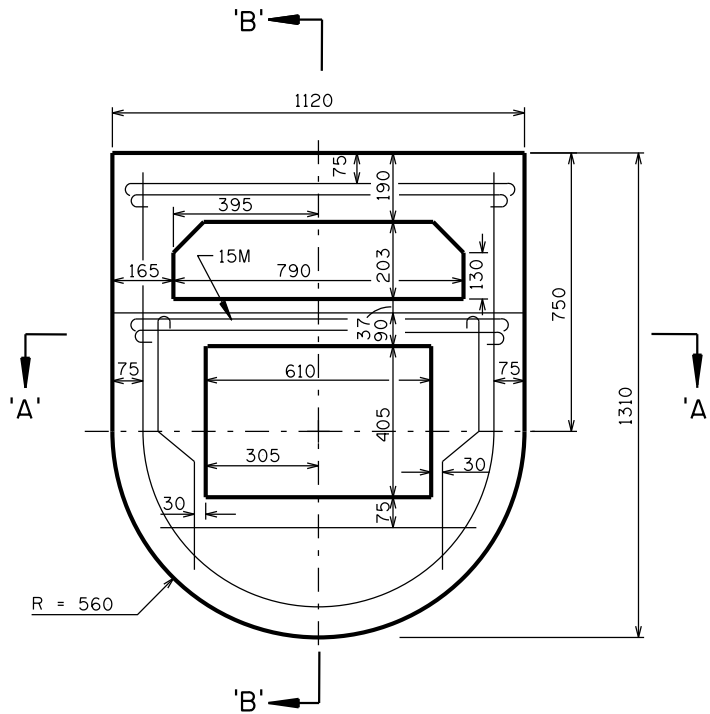

PLAN

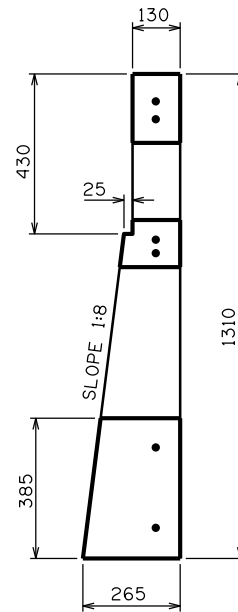

SECTION 'B-B'

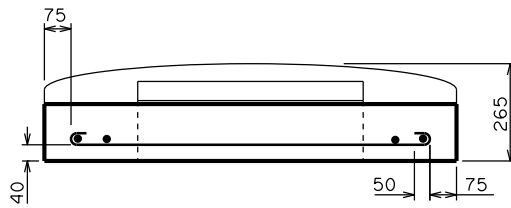

SECTION 'A-A'

NOTE:

- ALTERNATE PRECAST TOP TO BE USED IN CONJUNCTION WITH TYPE 'C' CATCH BASIN IN LOW PROFILE ROLLED CURB WITH 250mm GUTTER.

MATERIAL SPECIFICATIONS:

(ALL SPECIFICATIONS & STANDARDS REFER TO LATEST EDITION)

1. CEMENT: SULPHATE RESISTANT TYPE: TYPE HS (TYPE 50) TO CSA A3001 OR TYPE V TO ASTM C150.
2. CONCRETE COMPRESSIVE STRENGTH: 35MPa AT 28 DAYS.
3. AIR CONTENT: 4% TO 7% EXCEPT WHERE NO-SLUMP CONCRETE IS USED.
4. CONCRETE CLEAR COVER: 30mm MIN.
5. REINFORCING STEEL: DEFORMED BARS TO CSA G30.18, $f_y = 400MPa$ TO BE 15M BARS WITH COLD BENDS, INSIDE RADIUS 30mm & SLANTED.

DIMENSIONS ARE IN MILLIMETRES UNLESS OTHERWISE NOTED

No.	Date	Revision	App'd
4	2020/02/10	CONCRETE STRENGTH REVISED	S.P.
3	2005/09/19	REINFORCEMENT REVISED	
2	2004/11/19	REVISED MATERIAL SPECS	
1	2003/10/11	ADDITION TO TITLE BLOCK	

Date
1999/09/14

Scale
N.T.S.

Approved by
[Signature]

for The City of Calgary

SEWER CONSTRUCTION

ALTERNATE PRECAST TOP FOR TYPE 'C' CATCH BASIN ROLLED CURB

Sheet
27

File Number
452.1002.024

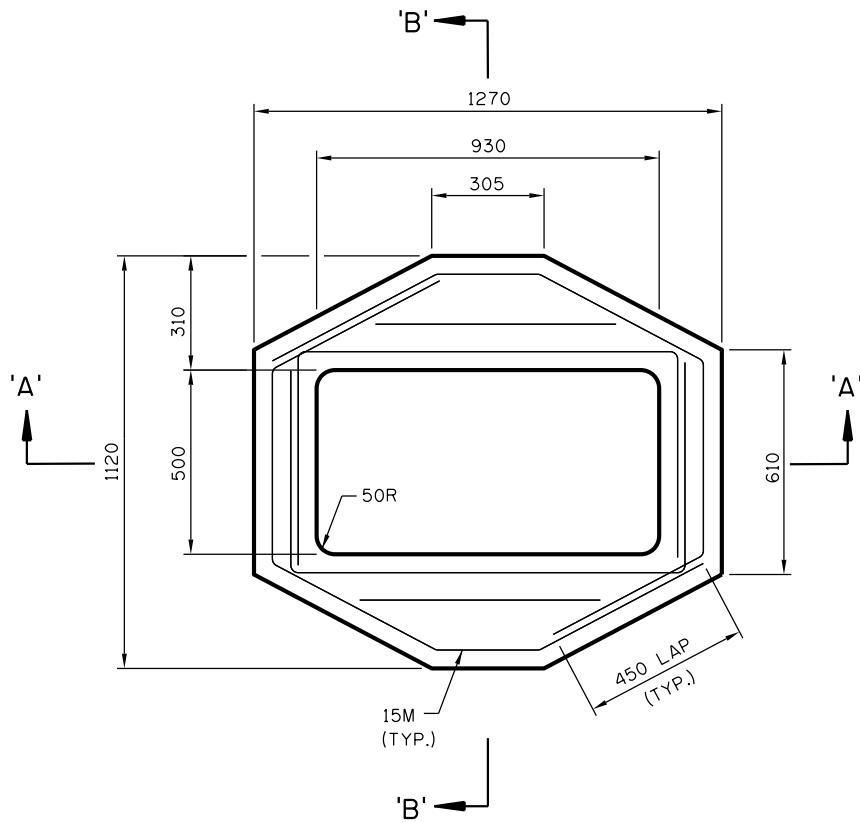

PLAN

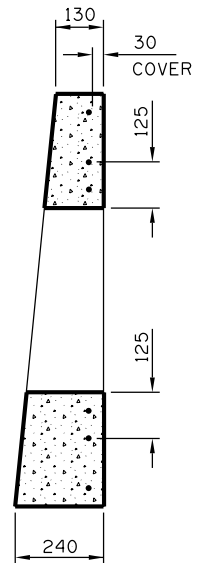

SECTION 'B-B'

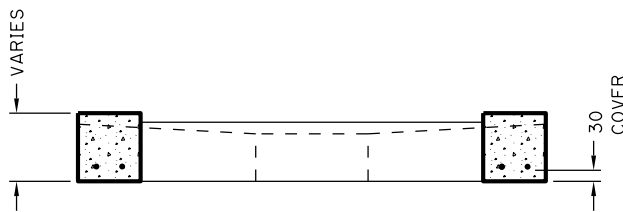

SECTION 'A-A'

MATERIAL SPECIFICATIONS:

(ALL SPECIFICATIONS & STANDARDS REFER TO LATEST EDITION)

1. CEMENT: SULPHATE RESISTANT TYPE: TYPE HS (TYPE 50) TO CSA A3001 OR TYPE V TO ASTM C150.
2. CONCRETE COMPRESSIVE STRENGTH: 35MP_a AT 28 DAYS.
3. AIR CONTENT: 4% TO 7% EXCEPT WHERE NO-SLUMP CONCRETE IS USED.
4. CONCRETE CLEAR COVER: 30mm MIN.
5. REINFORCING STEEL: DEFORMED BARS TO CSA G30.18, f_y = 400MP_a TO BE 15M BARS.

DIMENSIONS ARE IN MILLIMETRES UNLESS OTHERWISE NOTED

No.	Date	Revision
3	2020/02/10	CONCRETE STRENGTH REVISED
2	2005/09/19	REINFORCEMENT REVISED
1	2004/11/19	REVISED MATERIAL SPECS

Date
1999/09/14

Scale
N.T.S.

Approved by
[Signature]

for The City of Calgary

SEWER CONSTRUCTION

PRECAST SLAB TOP
FOR TYPE 'K-2'
CATCH BASIN

Sheet
28

File Number
452.1002.016

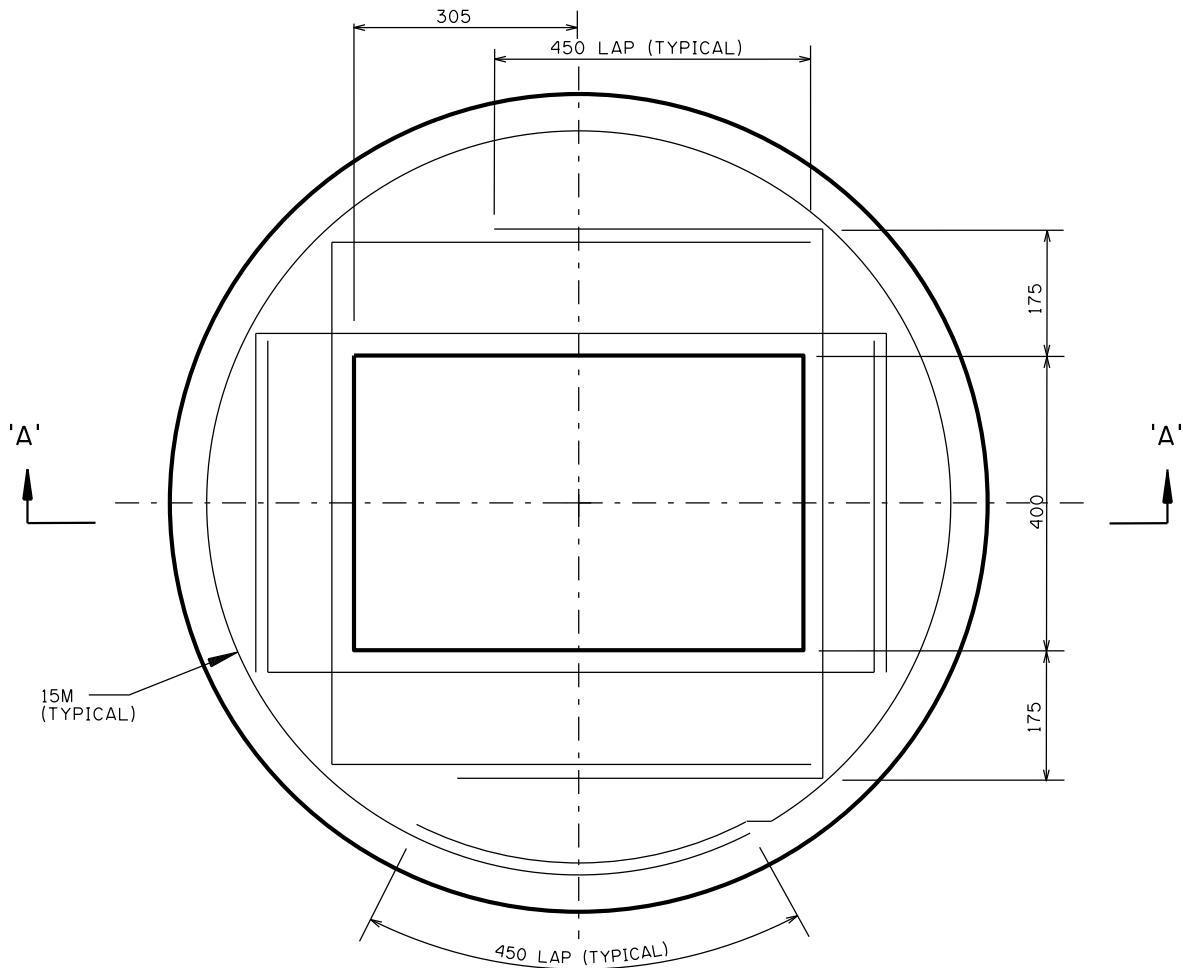

PLAN

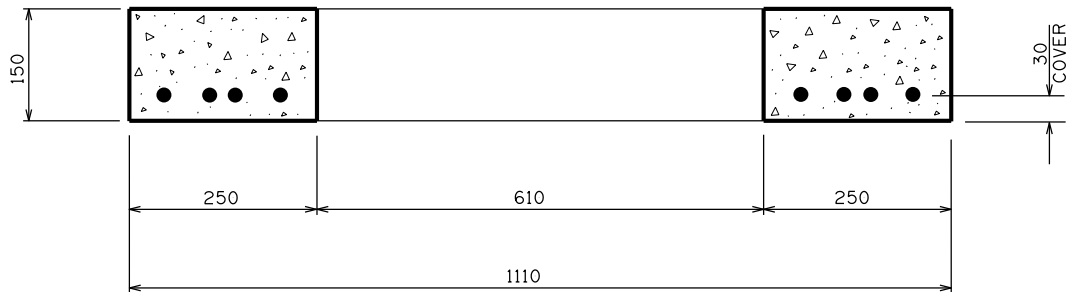

SECTION 'A-A'

MATERIAL SPECIFICATIONS:

(ALL SPECIFICATIONS & STANDARDS REFER TO LATEST EDITION)

1. CEMENT: SULPHATE RESISTANT TYPE: TYPE HS (TYPE 50) TO CSA A3001 OR TYPE V TO ASTM C150.
2. CONCRETE COMPRESSIVE STRENGTH: 35MP_a AT 28 DAYS.
3. AIR CONTENT: 4 TO 7% EXCEPT WHERE NO-SLUMP CONCRETE IS USED.
4. CONCRETE CLEAR COVER: 30mm MIN.
5. REINFORCING STEEL: DEFORMED BARS TO CSA G30.18, $f_y = 400$ MP_a REINFORCING STEEL TO BE SLANTED WHERE NECESSARY TO ACCOMMODATE SLAB THICKNESS.

NOTE: USE ROUND TOP IN PARKING LOTS, LANES OR DRIVEWAYS.

DIMENSIONS ARE IN MILLIMETRES UNLESS OTHERWISE NOTED

No.	Date	Revision
3	2020/02/10	CONCRETE STRENGTH REVISED
2	2005/09/20	REINFORCEMENT REVISED
1	2004/11/19	REVISED MATERIAL SPECS

Date
1999/09/14

Scale
N.T.S.

Approved by
[Signature]

for The City of Calgary

SEWER CONSTRUCTION

PRECAST SLAB TOP FOR
TYPE 'K-3'
CATCH BASIN

Sheet
29

File Number
452.1002.020

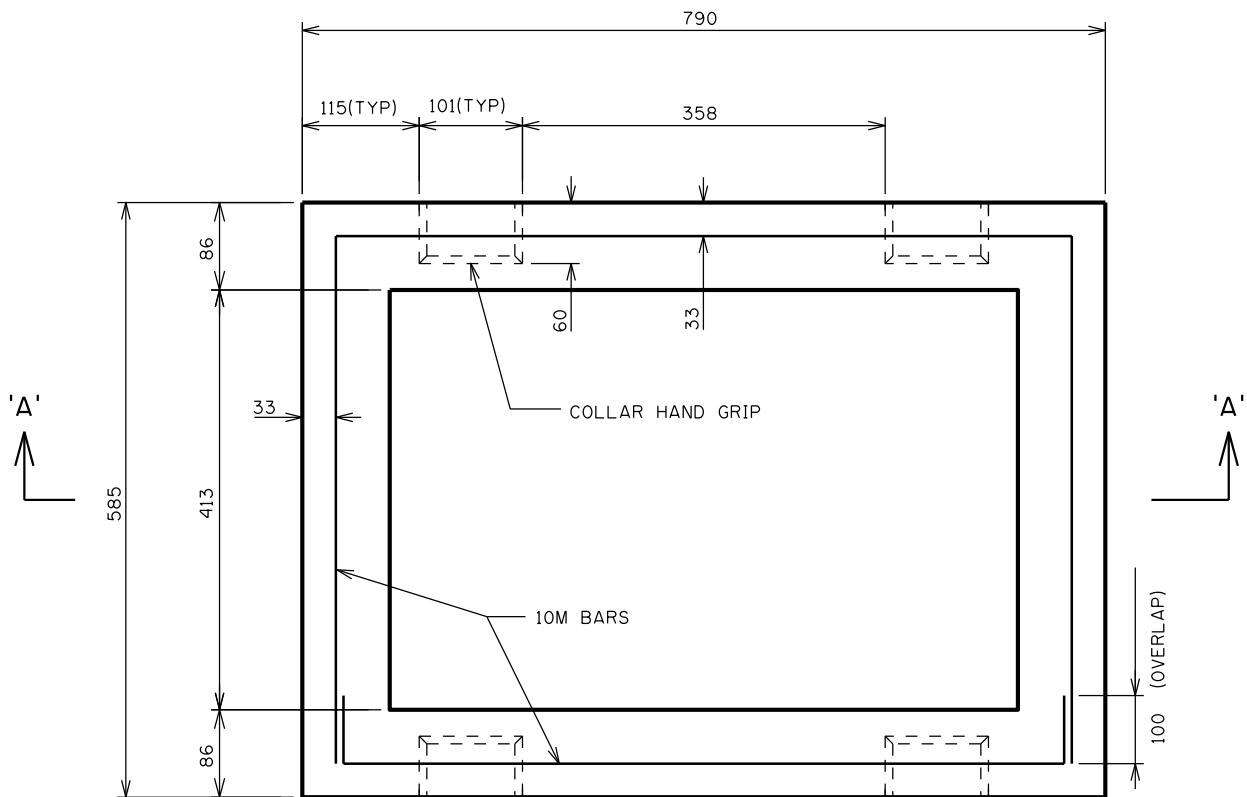

PLAN VIEW

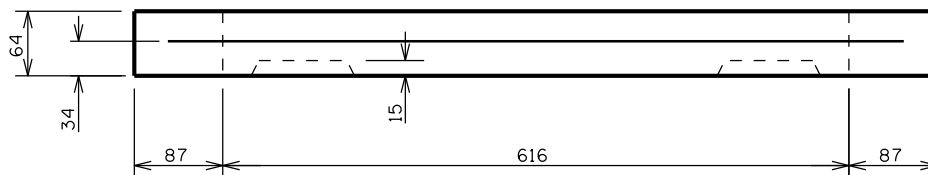

SECTION 'A-A'

MATERIAL SPECIFICATIONS:

(ALL SPECIFICATIONS & STANDARDS REFER TO LATEST EDITION)

1. MANUFACTURED TO ASTM C478 & CSA 257.4
2. CEMENT: SULPHATE RESISTANT TYPE: TYPE HS (TYPE 50) TO CSA A3001 OR TYPE V TO ASTM C150.
3. CONCRETE COMPRESSIVE STRENGTH: 35MP_a AT 28 DAYS.
4. CONCRETE COVER: 30mm MIN.
5. AIR CONTENT: 4% TO 7% EXCEPT WHERE NO-SLUMP CONCRETE IS USED.
6. REINFORCING STEEL: DEFORMED BARS TO CSA G30.18, $f_y = 400MP_a$ TO BE 10M BARS.

DIMENSIONS ARE IN MILLIMETRES UNLESS OTHERWISE NOTED

No.	Date	Revision
3	2020/02/10	CONCRETE STRENGTH REVISED
2	2006/10/13	A150 CHANGED TO C150
1	2004/11/19	REVISED MATERIAL SPECS

Date: 2002/09/10
 Scale: N.T.S.
 Approved by: *[Signature]*
 for The City of Calgary

SEWER CONSTRUCTION
CONCRETE CB COLLAR FOR 'K-3' CATCH BASIN

Sheet
29A
 File Number
 452.1002.037

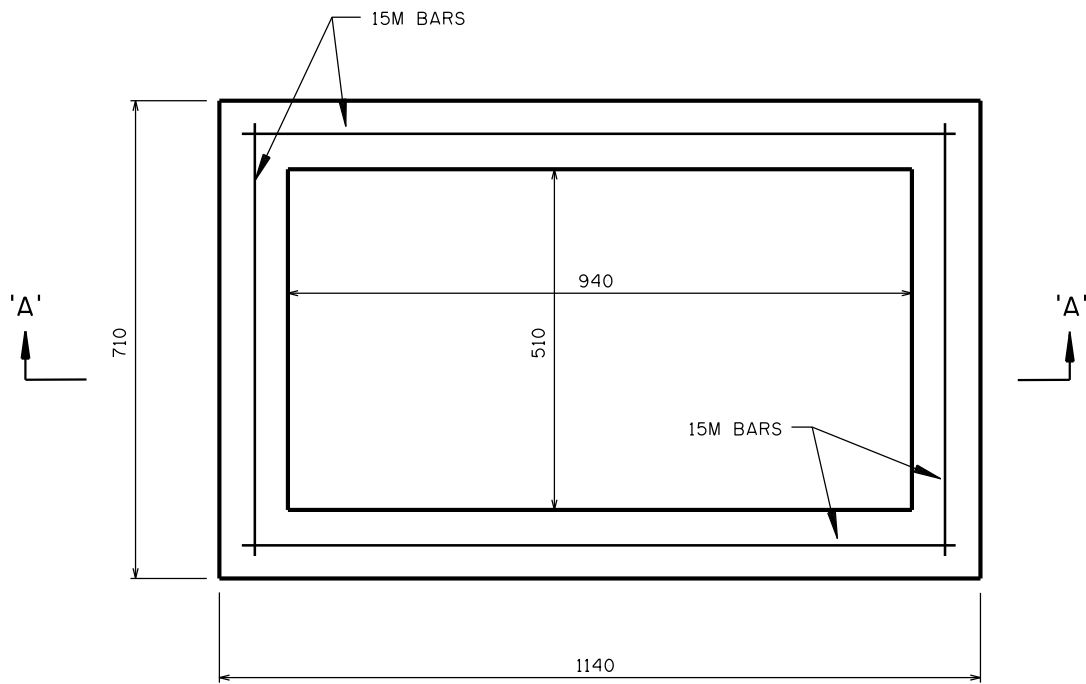

PLAN

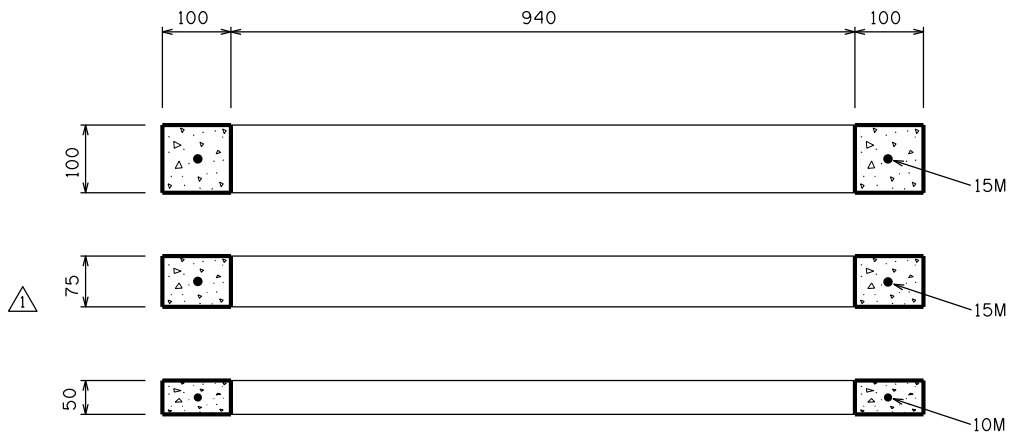

SECTION 'A-A'

NOTE:

50mm SIZE USES 10M INSTEAD OF 15M

MATERIAL SPECIFICATIONS:

(ALL SPECIFICATIONS & STANDARDS REFER TO LATEST EDITION)

1. CEMENT: SULPHATE RESISTANT TYPE: TYPE HS (TYPE 50) TO CSA A3001 OR TYPE V TO ASTM C150.
2. CONCRETE COMPRESSIVE STRENGTH: 35MP_a AT 28 DAYS.
3. AIR CONTENT: 4% TO 7% EXCEPT WHERE NO-SLUMP CONCRETE IS USED.
4. CONCRETE CLEAR COVER: 30mm MIN, EXCEPT FOR 50mm COLLAR SIZE.
5. REINFORCING STEEL: DEFORMED BARS TO CSA G30.18, f_y = 400MP_a.

DIMENSIONS ARE IN MILLIMETRES UNLESS OTHERWISE NOTED

			Date 1999/09/14	 Calgary	SEWER CONSTRUCTION	Sheet 30	
			Scale N.T.S.		PRECAST COLLAR FOR TYPE 'K-2' CATCH BASIN	File Number 452.1002.017	
2	2020/02/10	CONCRETE STRENGTH REVISED	S.P.	Approved by 			
1	2005/08/31	SIZES ADDED 50 & 75mm. AND TITLE BLOCK	App'd	for The City of Calgary			
No.	Date	Revision					

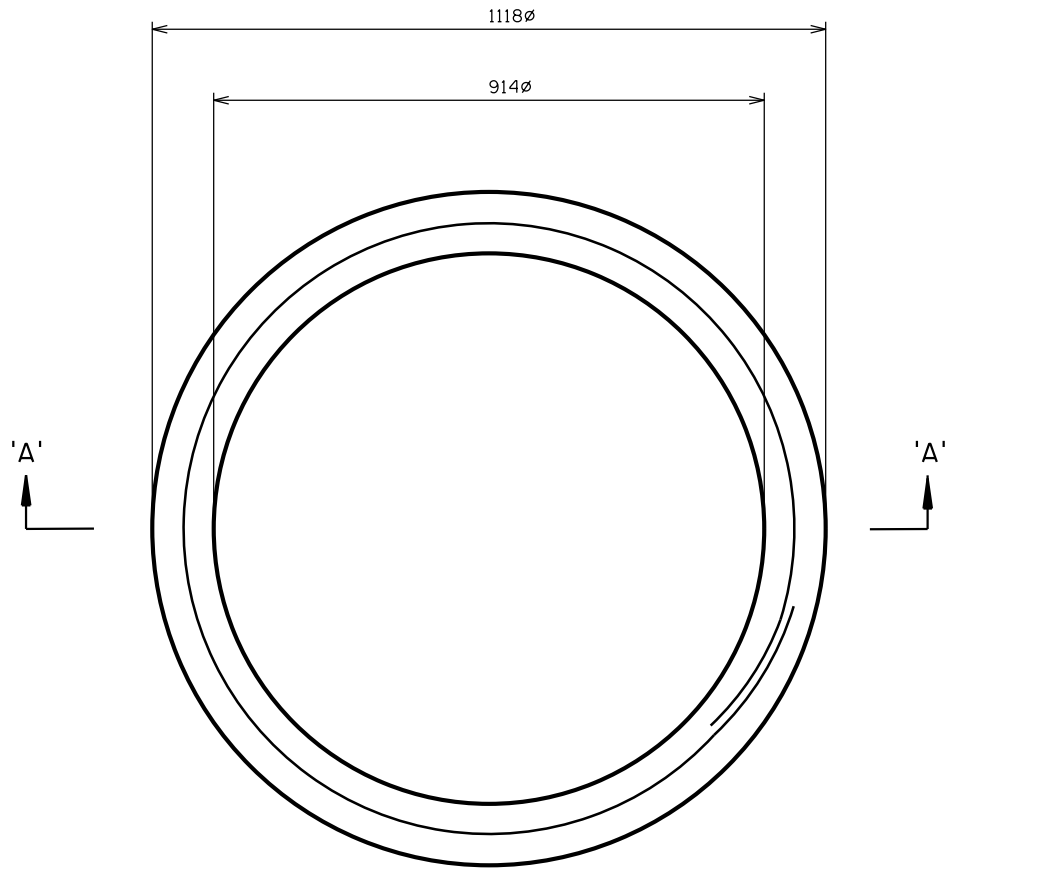

PLAN

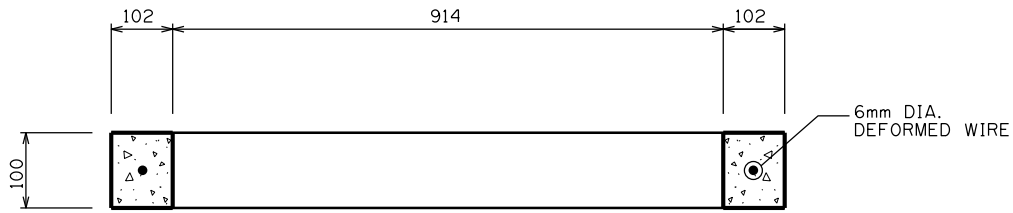

SECTION 'A-A'

MATERIAL SPECIFICATIONS:

(ALL SPECIFICATIONS & STANDARDS REFER TO LATEST EDITION)

1. CEMENT: SULPHATE RESISTANT TYPE: TYPE HS (TYPE 50) TO CSA A3001 OR TYPE V TO ASTM C150.
2. CONCRETE COMPRESSIVE STRENGTH: 35MPa AT 28 DAYS.
3. AIR CONTENT: 4% TO 7% EXCEPT WHERE NO-SLUMP CONCRETE IS USED.
4. CONCRETE CLEAR COVER: 30mm MIN.
5. DEFORMED WIRE REINFORCEMENT: D6 TO ASTM A496.

NOTE:

FOR USE BELOW SLAB TOP

DIMENSIONS ARE IN MILLIMETRES UNLESS OTHERWISE NOTED

				Date 2005/10/06			SEWER CONSTRUCTION		Sheet
				Scale N.T.S.			PRECAST FILLER PIECE (CIRCULAR) FOR TYPE 'K-2' CATCH BASIN		30A
				Approved by 				File Number	
1	2020/02/10	CONCRETE STRENGTH REVISED		S.P.	for The City of Calgary				452.1002.040
No.	Date	Revision		App'd					

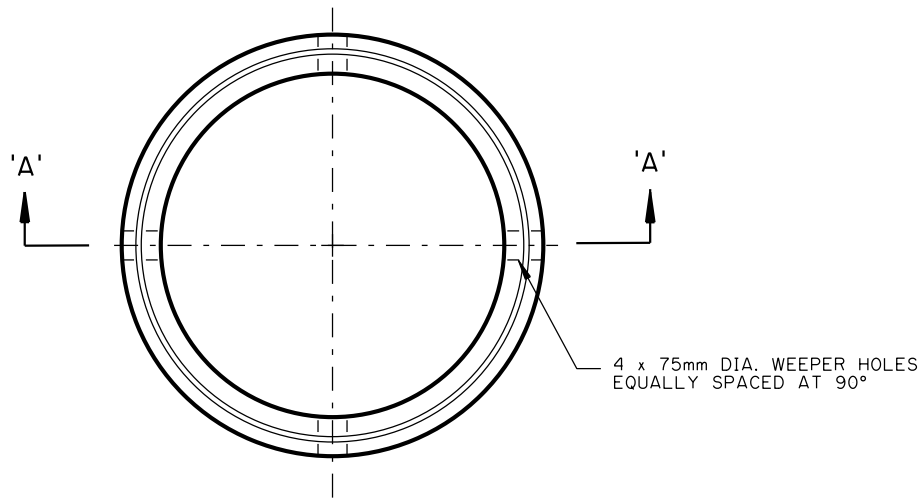

PLAN

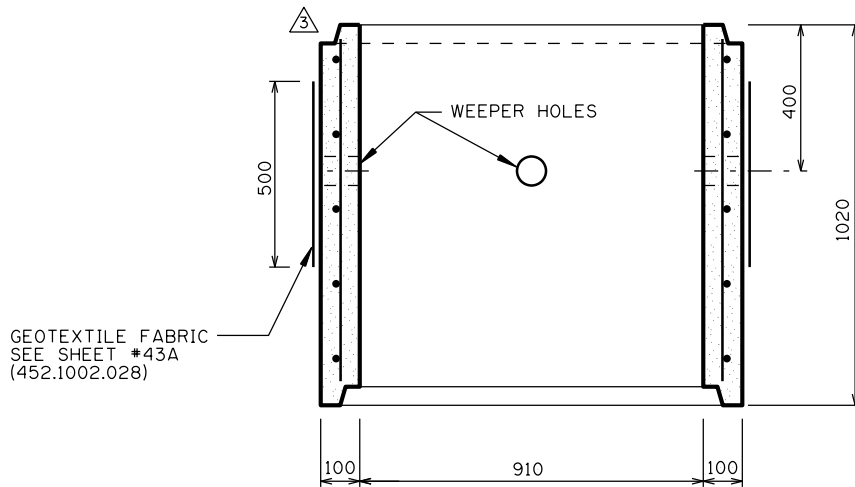

SECTION 'A-A'

MATERIAL SPECIFICATIONS:

(ALL SPECIFICATIONS & STANDARDS REFER TO LATEST EDITION)

1. MANUFACTURED TO ASTM C478 & CSA 257.4
2. CEMENT: SULPHATE RESISTANT TYPE: TYPE HS (TYPE 50) TO CSA A3001 OR TYPE V TO ASTM C150.
3. CONCRETE COMPRESSIVE STRENGTH: 35MPa AT 28 DAYS.
4. AIR CONTENT: 4% TO 7% EXCEPT WHERE NO-SLUMP CONCRETE IS USED.
5. REINFORCING STEEL: DEFORMED BARS TO CSA G30.18, $f_y = 400\text{MPa}$.

DIMENSIONS ARE IN MILLIMETRES
UNLESS OTHERWISE NOTED

No.	Date	Revision	App'd	Date	Scale	Approved by	Sheet
4	2020/02/10	CONCRETE STRENGTH REVISED	S.P.	1999/09/14	N.T.S.	 Approved by <i>[Signature]</i> for The City of Calgary	31
3	2019/12/13	CHANGED JOINT EDGE TO SPIGOT & ADDED STRAP	B.N.				File Number
2	2006/10/13	A150 CHANGED TO C150					452.1002.027
1	2004/11/19	REVISED MATERIAL SPECS					

SEWER CONSTRUCTION
**CATCH BASIN
PRECAST BARREL**

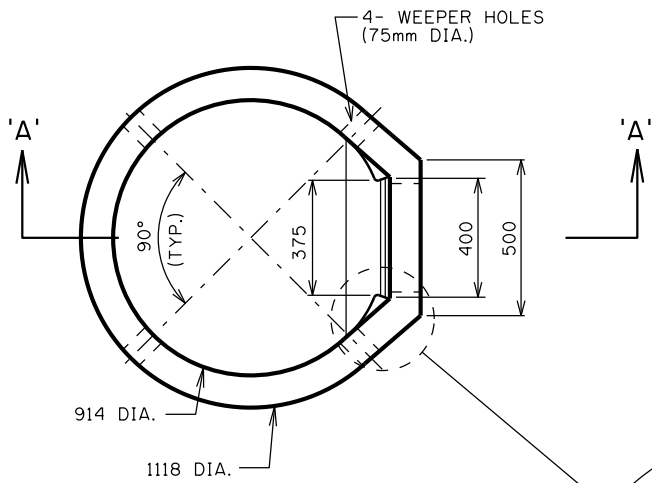

PLAN

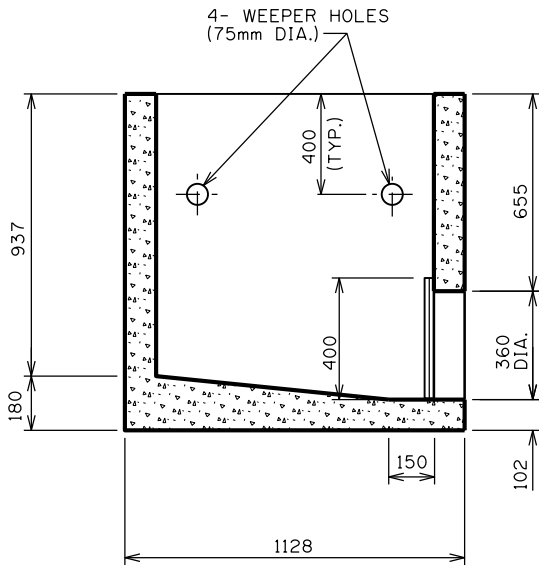
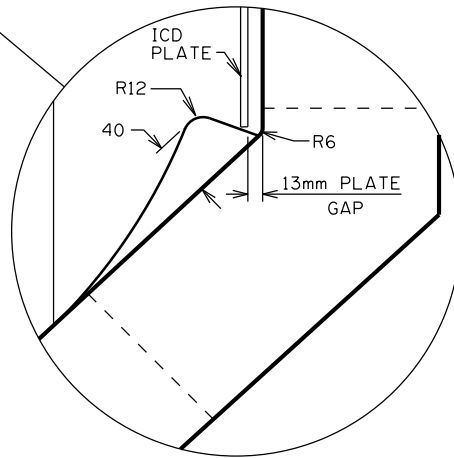

SECTION 'A-A'

MATERIAL SPECIFICATIONS:

(ALL SPECIFICATIONS & STANDARDS REFER TO LATEST EDITION)

1. MANUFACTURED TO ASTM C478 & CSA 257.4
2. CEMENT-SULPHATE RESISTANT TYPE TYPE HS (TYPE 50) TO CSA A3001 OR TYPE V TO ASTM C150 Δ
- Δ 3. CONCRETE COMPRESSIVE STRENGTH: 35 MPa AT 28 DAYS
4. AIR CONTENT: 4% TO 7% EXCEPT WHERE NO-SLUMP CONCRETE IS USED
5. REINFORCING STEEL: DEFORMED BARS TO CSA G30.18, $f_y = 400\text{MPa}$

NOTES:

ICD PLATE AS PER SHEET #43B (452.1002.031) FLAT PLATE DESIGN
 395mm W x 375mm H x 6mm THICK
 IF A CONNECTOR IS TO BE PREINSTALLED AT THE MANUFACTURING PLANT, PRIOR APPROVAL BY WATER

Δ RESOURCES IS REQUIRED

DIMENSIONS ARE IN MILLIMETRES UNLESS OTHERWISE NOTED

No.	Date	Revision
2	2020/02/13	REVISED NOTE
1	2005/10/01	REVISED TEXT

Date
2001/02/05
Scale
N.T.S.
Approved by
J. Simpson
for The City of Calgary

SEWER CONSTRUCTION
PRECAST MONOLITHIC CATCH BASIN BASE

Sheet
31A
 File Number
 452.1002.032

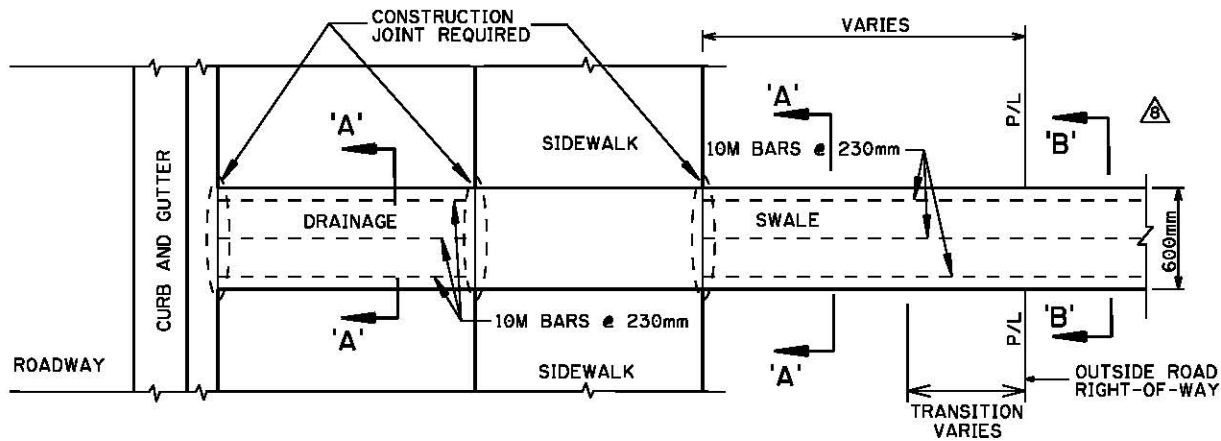

PLAN

NOTE:

WHERE A DRAINAGE SWALE CROSSES A SIDEWALK AND/OR BOULEVARD, THE CONSULTING ENGINEER SHALL PROVIDE DETAILED DRAINAGE SWALE DRAWING WHERE THE INTERSECTING STREET HAS GREATER THAN 3.0% GRADE. REFER TO ROADS CONSTRUCTION SPECIFICATIONS 454.1013.015 (DWG *46) & 454.1013.016 (DWG *48) FOR SEPARATE MONO & BOULEVARD CROSSING DETAILS.

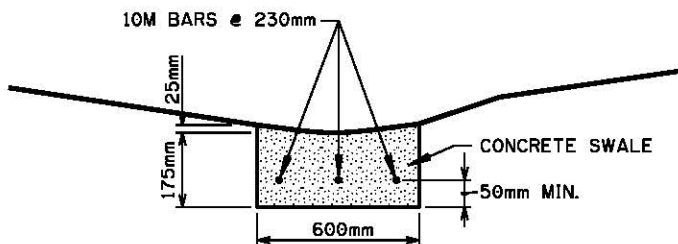

SECTION 'A-A'

TYPICAL (WITHIN ROAD RIGHT-OF-WAY)

REINFORCEMENT OPTIONS:
ACCEPTABLE REINFORCEMENT
FIBRE CONCRETE OR STEEL BARS

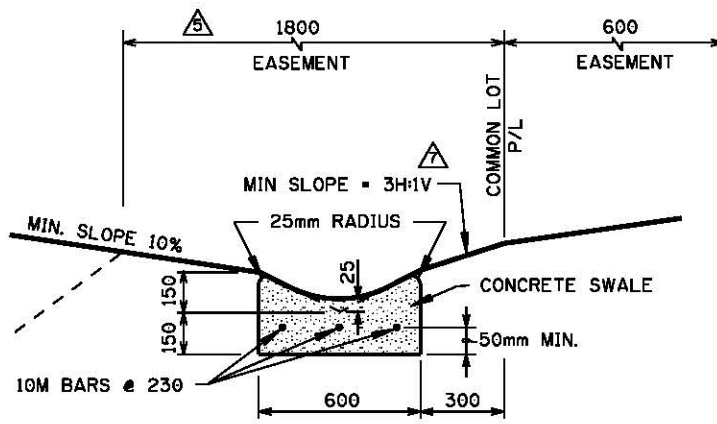

SECTION 'B-B'

TYPICAL (OUTSIDE ROAD RIGHT-OF-WAY)

MATERIAL SPECIFICATIONS:

- CONCRETE AS SET OUT UNDER SECTION 403.10.08
- REINFORCING STEEL TO BE DEFORMED BARS $f_y=400MPa$ (CONFORM TO C.S.A. SPEC. G30.18 - LATEST EDITION).
- COVERING FOR REINFORCING STEEL SHALL BE 50mm.
- ALL LAPS SHALL BE 30 BAR DIAMETERS. ALL LAPS MUST BE TIED SECURELY.
- REINFORCING BARS TO BE EXTENDED INTO CURB, GUTTER AND SIDEWALK.
- REINFORCEMENT OR FIBRE CONCRETE (OPTIONAL) - FIBRE CONCRETE SPECIFICATION - SEE ROADS CONSTRUCTION SPEC. (MOST RECENT VERSION) SECTION 310.01.04.
- CONSTRUCTION JOINTS AS PER ROADS CONSTRUCTION SPEC.- JOINT DETAILS *454.1015.006.

NOTE:

1. FOR 'DEEP SWALES' WITH DEPTHS GREATER THAN 125mm, ADD AN ADDITIONAL 10M BAR @150mm MIN. IN EACH SHOULDER. ENSURE 50mm MINIMUM COVER. SEE SHEET 32C
2. TOTAL DEPTH OF CONCRETE CHANNEL TO BE 300mm ONLY FOR STANDARD DRAINAGE GUTTER OUTSIDE ROAD RIGHT-OF-WAY. TOTAL DEPTH OF CONCRETE CHANNEL FOR MONO SIDEWALK, SEPARATE SIDEWALK & BOULEVARD CROSSINGS WITHIN ROAD RIGHT-OF-WAY WILL BE 200mm AS PER ROADS CONSTRUCTION SPECIFICATIONS FILE *454.1013.015 (DWG *46) & *454.1013.016 (DWG *48).

DIMENSIONS ARE IN MILLIMETRES UNLESS OTHERWISE NOTED

9	2018/04/30	REVISE DWG NUMBERS	MC	Drawn Date	1999/09/14		SEWER CONSTRUCTION	Sheet	32
8	2010/09/13	DELETE SEC B-B. RENAME SEC C-C TO SEC B-B		Date	N.T.S				
7	2007/11/29	MIN SLOPE REVISED TO 3%		Scale					
6	2006/09/26	REMOVAL OF NOTE 3 & ALTERNATE EASEMENT; REVISE TEXT		Approved by					
5	2005/09/20	ALTERNATE EASEMENT		for the City of Calgary			STANDARD DRAINAGE SWALE EASEMENT CROSSING	File Number	452.1006.002
4	2003/11/10	CHANGE GUTTER TO SWALE							
No.	Date	Revision	App'd						

DRAWING 32A: DELETED

This drawing is no longer applicable to Standard Specifications Sewer Construction. It can be found in Standard Specifications Road Construction, Sheet #46.

DRAWING 32B: DELETED

This drawing is no longer applicable to Standard Specifications Sewer Construction. It can be found in Standard Specifications Road Construction, Sheet #48.

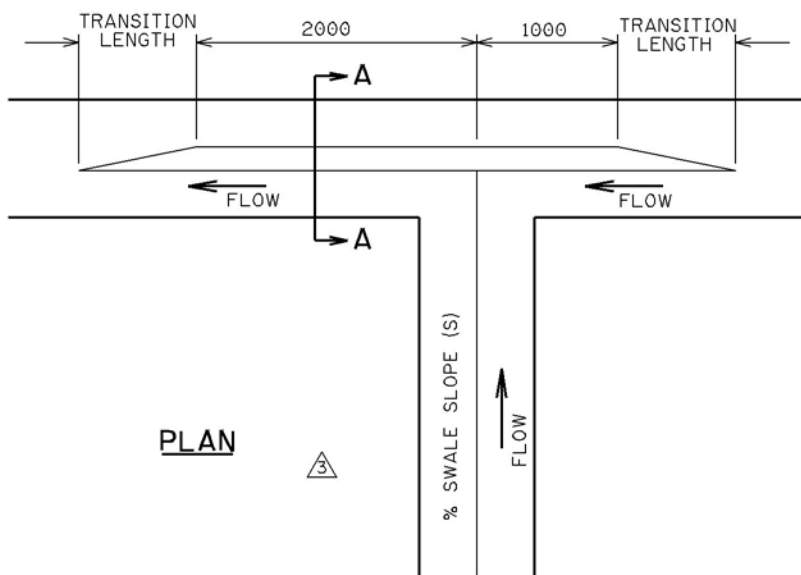

PLAN

HIGH-BACK SWALE

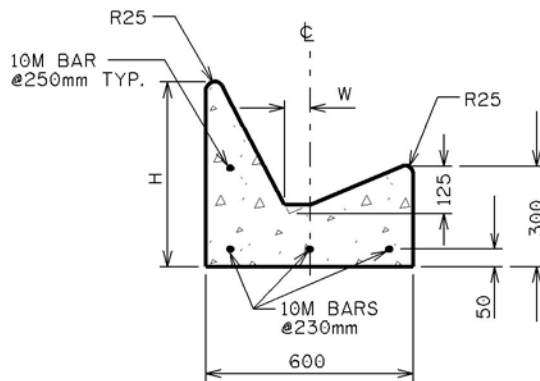

SECTION A-A

MIN. H=450 mm
 MIN. W=75 mm
 MIN. TRANSITION LENGTH (TL)=600 mm
 WHERE S>3%, USE:
 H=(300+50S) mm

$$\triangle S W=150 - \left[\frac{4500 \text{ mm}}{2H-300} \right] \times 10$$

$$TL=2(H-150) \text{ mm}$$

NOTES:

- (1) TO BE USED AT ALL T-INTERSECTIONS AND AT ALL HORIZONTAL DEFLECTIONS >fθ

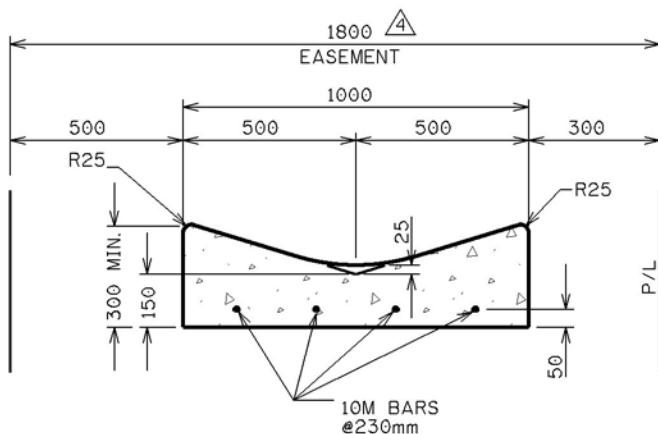

OVERLAND ESCAPE ROUTE SWALE

NOTES:

- (1) TO BE USED AT ALL LOCATIONS WHERE OVERLAND ESCAPE FOR A TRAPPED LOW IS NOT ALONG A ROADWAY OR A PAVED PATHWAY.
- (2) THIS IS THE MINIMUM ACCEPTABLE SIZE. EACH SITUATION MUST BE EVALUATED SEPERATELY TO ENSURE THE SWALE HAS AN ADEQUATE CROSS-SECTIONAL AREA TO CONVEY THE ANTICIPATED FLOWS.

- $\triangle S$ (3) FOR SWALES WITH DEPTHS GREATER THAN 125mm, ADD AN ADDITIONAL 10M BAR AT 150mm MIN. IN EACH SHOULDER. ENSURE 50mm MINIMUM COVER.

- $\triangle S$ (4) REINFORCEMENT OR FIBRE CONCRETE OPTIONAL - FIBRE CONCRETE SPECIFICATION - SEE ROADS CONSTRUCTION SPECIFICATIONS (MOST RECENT VERSION) SECTION 310.01.04.

DIMENSIONS ARE IN MILLIMETRES UNLESS OTHERWISE NOTED

5	2014/01/06	REVISED FORMULA FOR W	
4	2007/08/23	ADD DIMENSIONS	
3	2003/11/10	GUTTER CHANGED TO SWALE	
2	2002/11/07	NOTE ADDED	
1	2002/01/09	GENERAL REVISION	
No.	Date	Revision	App'd

Date
1998/12/16

Scale
N.T.S.

Approved by
AS

for The City of Calgary

SEWER CONSTRUCTION

SWALE DETAIL
HIGH-BACK AND
OVERLAND ESCAPE ROUTE

Sheet
32C

File Number
452.1006.003

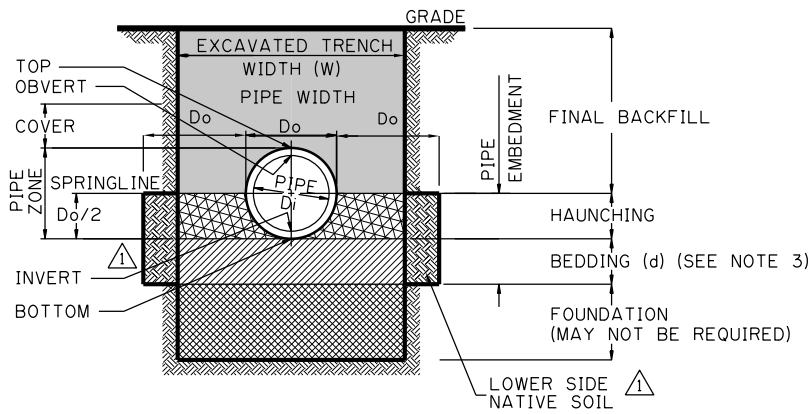

TERMINOLOGY

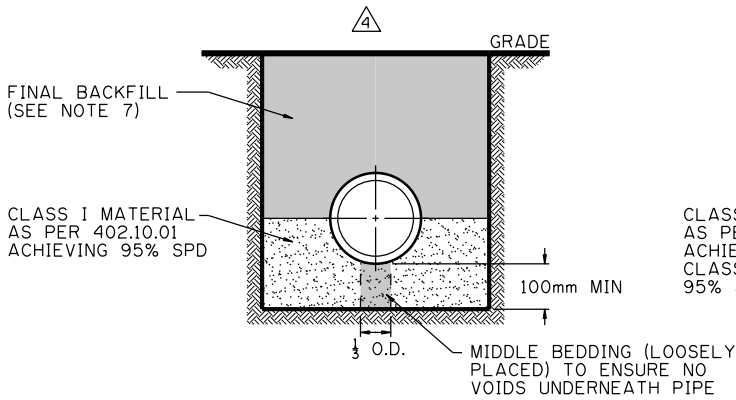

TYPE 1 INSTALLATION

TYPE 1 INSTALLATION REQUIRES THAT THE MATERIAL, DENSITY AND METHOD OF INSTALLATION BE CERTIFIED BY PROFESSIONAL ENGINEER.

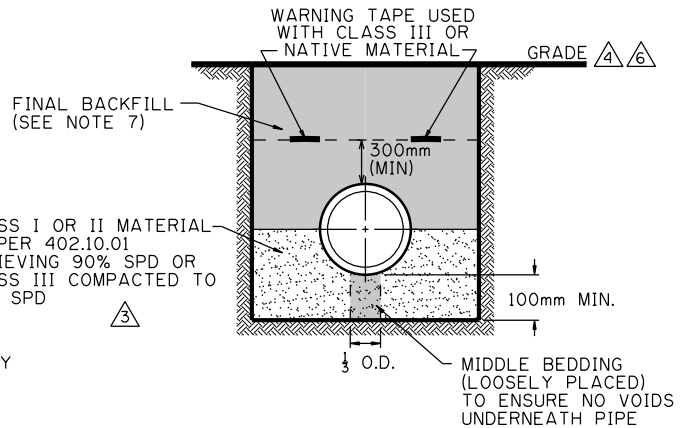

TYPE 2 INSTALLATION

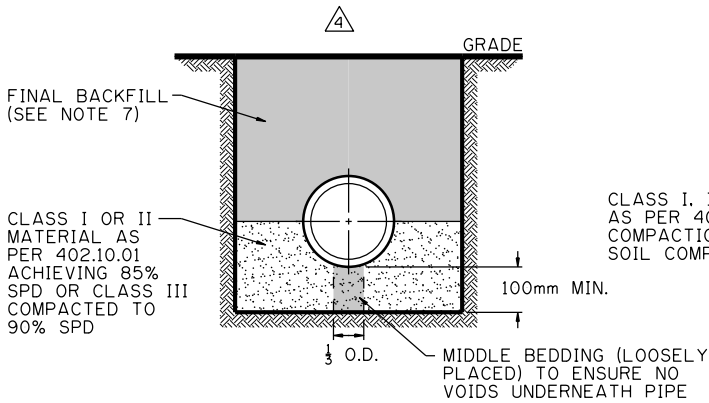

TYPE 3 INSTALLATION

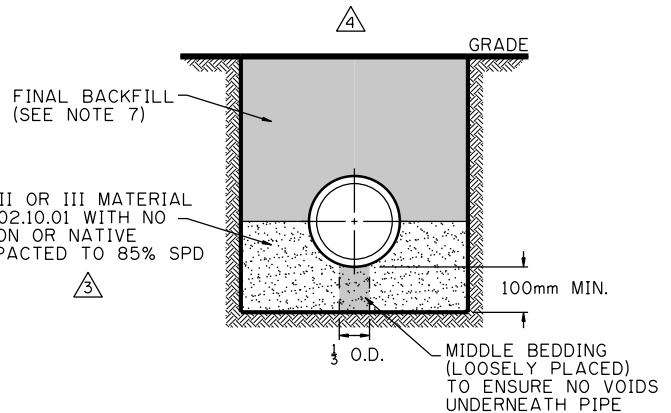

TYPE 4 INSTALLATION

NOTES:

1. BEDDING UNDER THE MIDDLE THIRD OF THE PIPE SHALL BE LOOSE, UNCOMPACTED MATERIAL.
2. IF ON A ROCK FOUNDATION, THEN MINIMUM BEDDING THICKNESS IS $D_o/12$ (NOT LESS THAN 150mm).
3. IF D_o IS GREATER THAN 2400mm, THEN MINIMUM BEDDING THICKNESS IS $D_o/24$.
4. FOR INITIAL BACKFILL MATERIAL OPTIONS IN A RIGID (CONCRETE) PIPE INSTALLATION, SEE SECTION 403.04.04.
5. SEE ALSO SECTION 403.04.04 FOUNDATION AND EMBEDMENT INSTALLATION.
6. ADVISE ENGINEER IF LOWER SIDE NATIVE SOILS ARE SOFTER OR LOOSER THAN PIPE EMBEDMENT SOILS AS PER SECTION 403.04.05 (CHANGE IN NATIVE SOIL CONDITIONS).
7. FINAL BACKFILL SOIL MAY CONSIST OF CLASSIFIED SOIL OR NATIVE MATERIAL AS PER SECTION 403.04.06

DIMENSIONS ARE IN MILLIMETRES UNLESS OTHERWISE NOTED

6	2020/02/13	ADDED WARNING TAPE NOTE AND DETAIL	M.C.	Date	2004/11/15		SEWER CONSTRUCTION	Sheet	33
5	2018/01/30	REMOVED NOTE 8 AND REVISED NOTE 2	M.C.	Scale	N.T.S.				
4	2016/11/28	REVISED DRAWING FOR RIGID PIPE ONLY		Approved by			BEDDING AND BACKFILL DETAILS FOR RIGID PIPE	File Number	452.1005.003
3	2014/03/19	REVISED NOTES		for The City of Calgary					
2	2013/12/10	REVISED NOTE 6							
1	2006/10/19	LOWER SIDE NATIVE SOIL ADDED							
No.	Date	Revision	App'd						

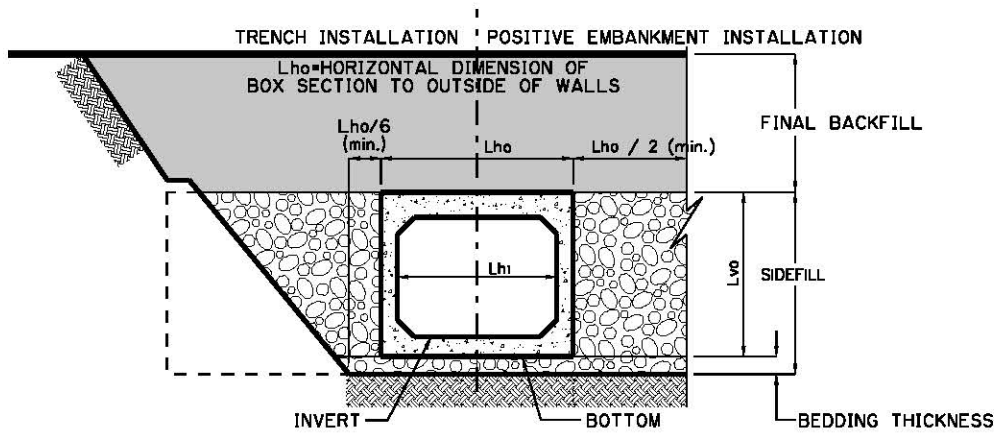

TERMINOLOGY

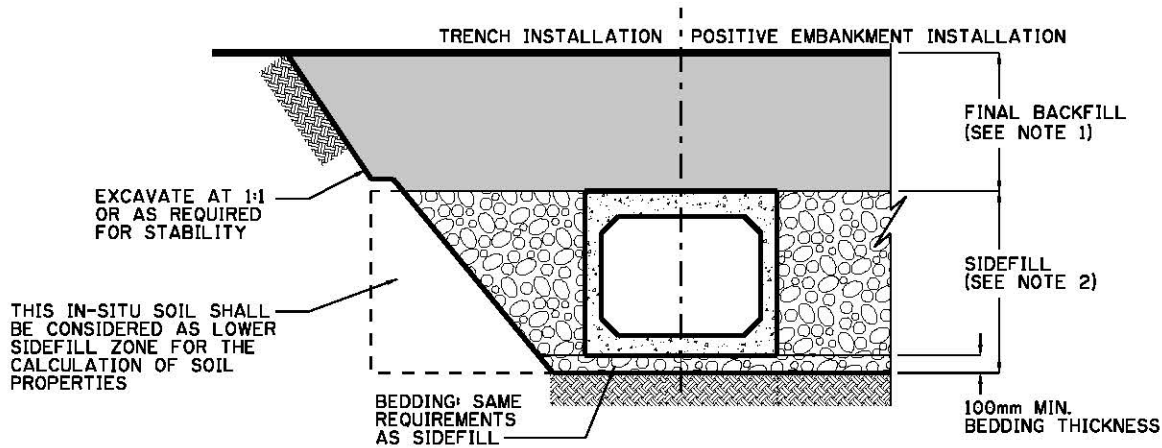

INSTALLATION

NOTES:

1. FINAL BACKFILL SHALL BE SUITABLE SITE MATERIAL AS PER SECTION 403.04.06 COMPACTED IN ACCORDANCE WITH THE GEOTECHNICAL REPORT OR AS DETERMINED BY THE DESIGNER OR ENGINEER.
2. SIDEFILL SHALL BE CLASS I OR II MATERIAL AS PER 402.10.01 ACHIEVING 90% SPD OR CLASS III COMPACTED TO 95% SPD.
3. DEPENDING ON SOIL MATERIALS AND ON-SITE CONDITIONS, THIS DRAWING WILL BE SUPPLEMENTED OR SUPERCEDED BY SITE SPECIFIC DESIGN DRAWINGS, ASSEMBLY DRAWINGS, SPECIAL PROVISIONS, AND ENVIRONMENTAL REQUIREMENTS WHERE APPLICABLE.

DIMENSIONS ARE IN MILLIMETRES UNLESS OTHERWISE NOTED

		Date 2017/01/12		SEWER CONSTRUCTION	Sheet 33A
		Scale N.T.S.			Approved by
1	2018/01/30	REVISED TITLE FROM CULVERT TO CONDUIT PIPE	MC		
No.	Date	Revision	App'd	for The City of Calgary	

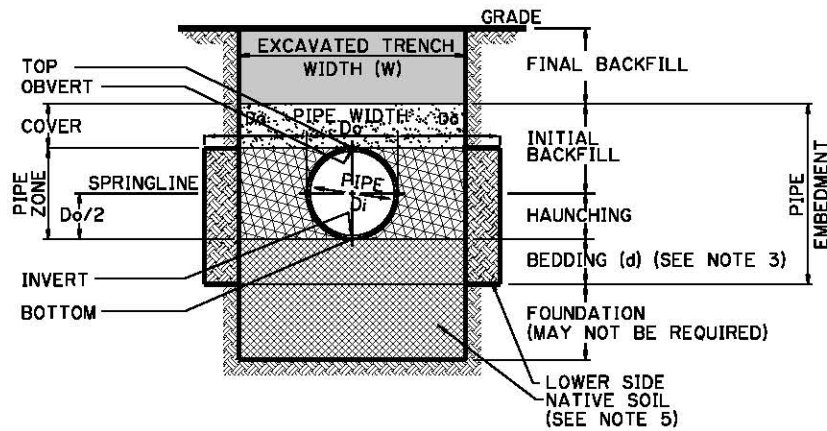

TERMINOLOGY

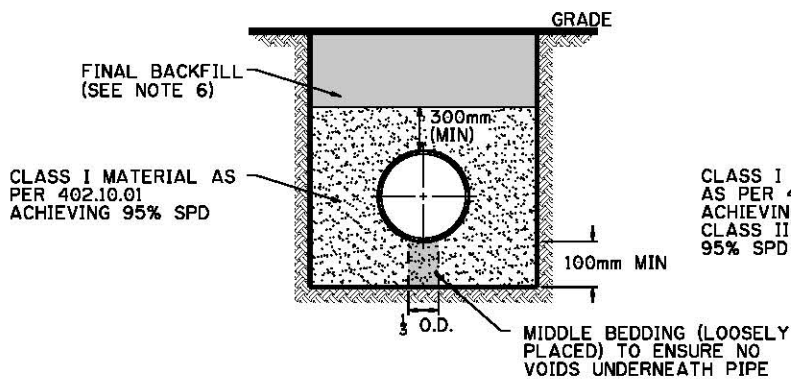

TYPE 1 INSTALLATION

TYPE 1 INSTALLATION REQUIRES THAT THE MATERIAL, DENSITY AND METHOD OF INSTALLATION BE CERTIFIED BY PROFESSIONAL ENGINEER.

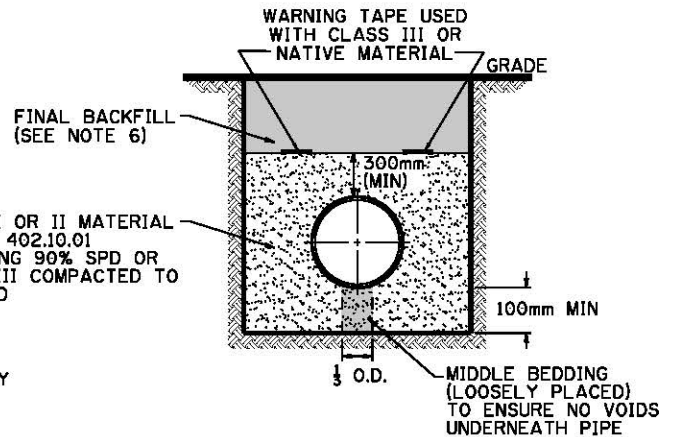

TYPE 2 INSTALLATION

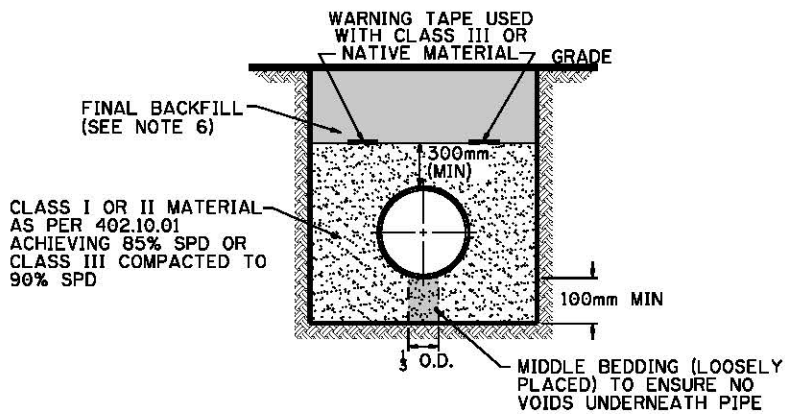

TYPE 3 INSTALLATION

NOTES:

- BEDDING UNDER THE MIDDLE THIRD OF THE PIPE SHALL BE LOOSE, UNCOMPACTED MATERIAL.
- IF ON A ROCK FOUNDATION, THEN MINIMUM BEDDING THICKNESS IS $D_o/12$ (NOT LESS THAN 150mm).
- IF D_o IS GREATER THAN 2400mm, THEN MINIMUM BEDDING THICKNESS IS $D_o/24$.
- SEE ALSO SECTION 403.04.04 FOUNDATION AND EMBEDMENT INSTALLATION.
- ADVISE ENGINEER IF LOWER SIDE NATIVE SOILS ARE SOFTER OR LOOSER THAN PIPE EMBEDMENT SOILS AS PER SECTION 403.04.05 (CHANGE IN NATIVE SOIL CONDITIONS).
- FINAL BACKFILL SOIL MAY CONSIST OF CLASSIFIED SOIL OR NATIVE MATERIAL AS PER SECTION 403.04.06.
- TYPE 4 INSTALLATION NOT ALLOWED FOR FLEXIBLE PIPE.

DIMENSIONS ARE IN MILLIMETRES UNLESS OTHERWISE NOTED

			Date 2018/01/30		SEWER CONSTRUCTION	Sheet 33B
			Scale N.T.S.			Approved by for The City of Calgary
No.	Date	Revision	App'd			

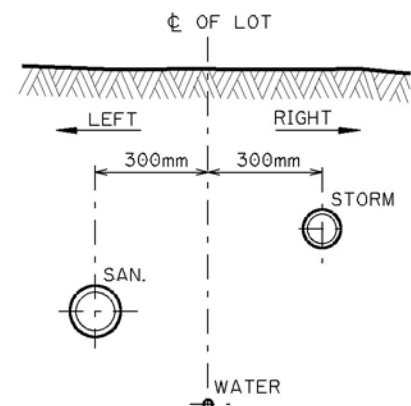
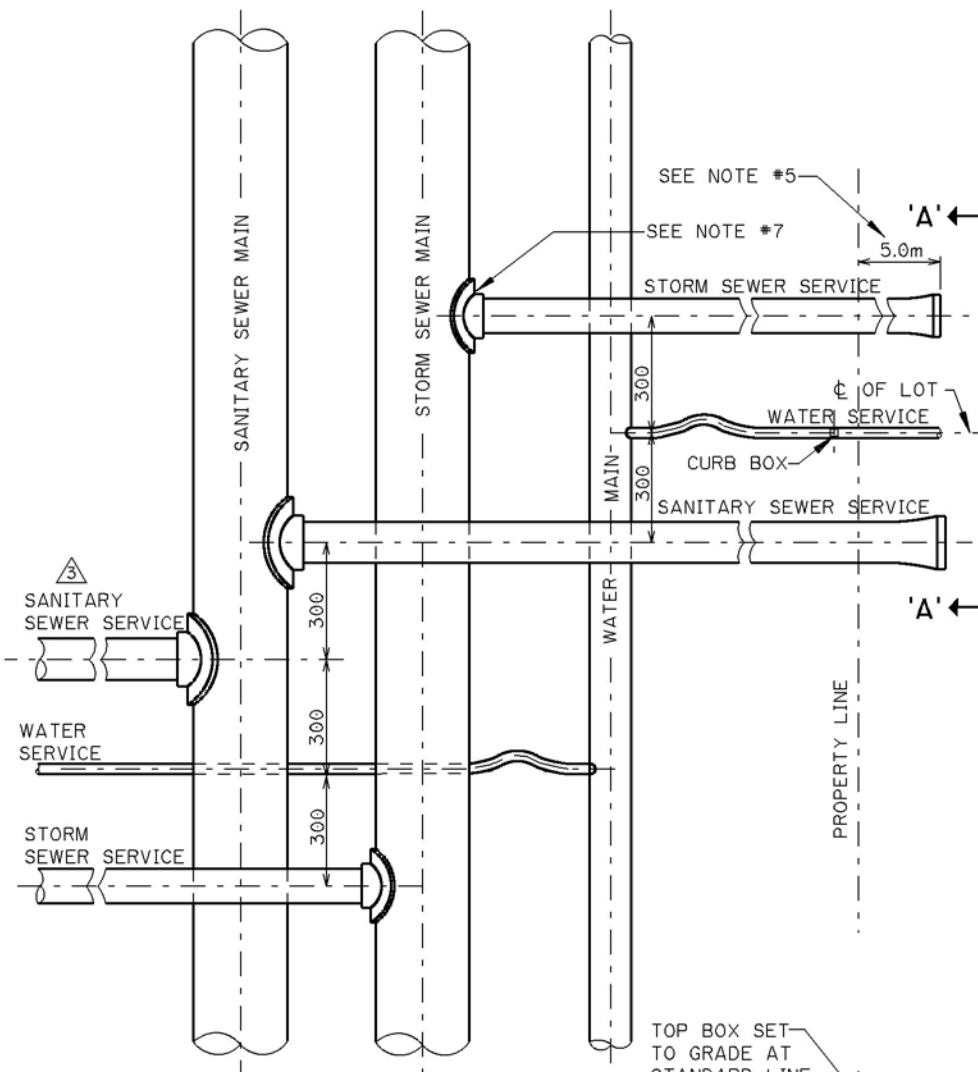

SECTION 'A-A'

LOOKING FROM INSIDE LOT
TOWARDS SEWER MAINS

NOTES:

1. CURB BOX LOCATED ON CENTRE LINE OF LOT UNLESS SPECIFIED OTHERWISE.
2. VIEWING THE TRENCH FROM THE LOT, THE STORM SEWER SERVICE IS LOCATED TO THE RIGHT OF THE CURB BOX AND THE SANITARY SEWER SERVICE TO THE LEFT.
3. THE INSTALLATION SHALL BE IN ACCORDANCE WITH SEC. 504.11.00 OF WATERWORKS SPECS.
4. SEWER SERVICES MUST TERMINATE WITH A BELL OR PLAIN END SEALED WITH AN APPROVED PLUG OR CAP.
5. UNDER SUBDIVISION AGREEMENT, THE SERVICES SHALL TERMINATE INSIDE PROPERTY LINE AS SPECIFIED IN SEC. 504.11.00. W.W. CONSTRUCTIONS.
6. SERVICE LEAD PIPE SIZES:
STORM - 75mm
SANITARY - 100mm
7. SANITARY/STORM SERVICE LEAD TO MAIN SHALL BE WITH
- APPROVED 100mm TEES, SADDLES OR MANUFACTURED TEE WITHIN STORM MAIN.
- MANUFACTURED APPROVED REDUCER SHALL BE USED TO JOIN THE 75mm LEAD TO THE 100mm TEE.

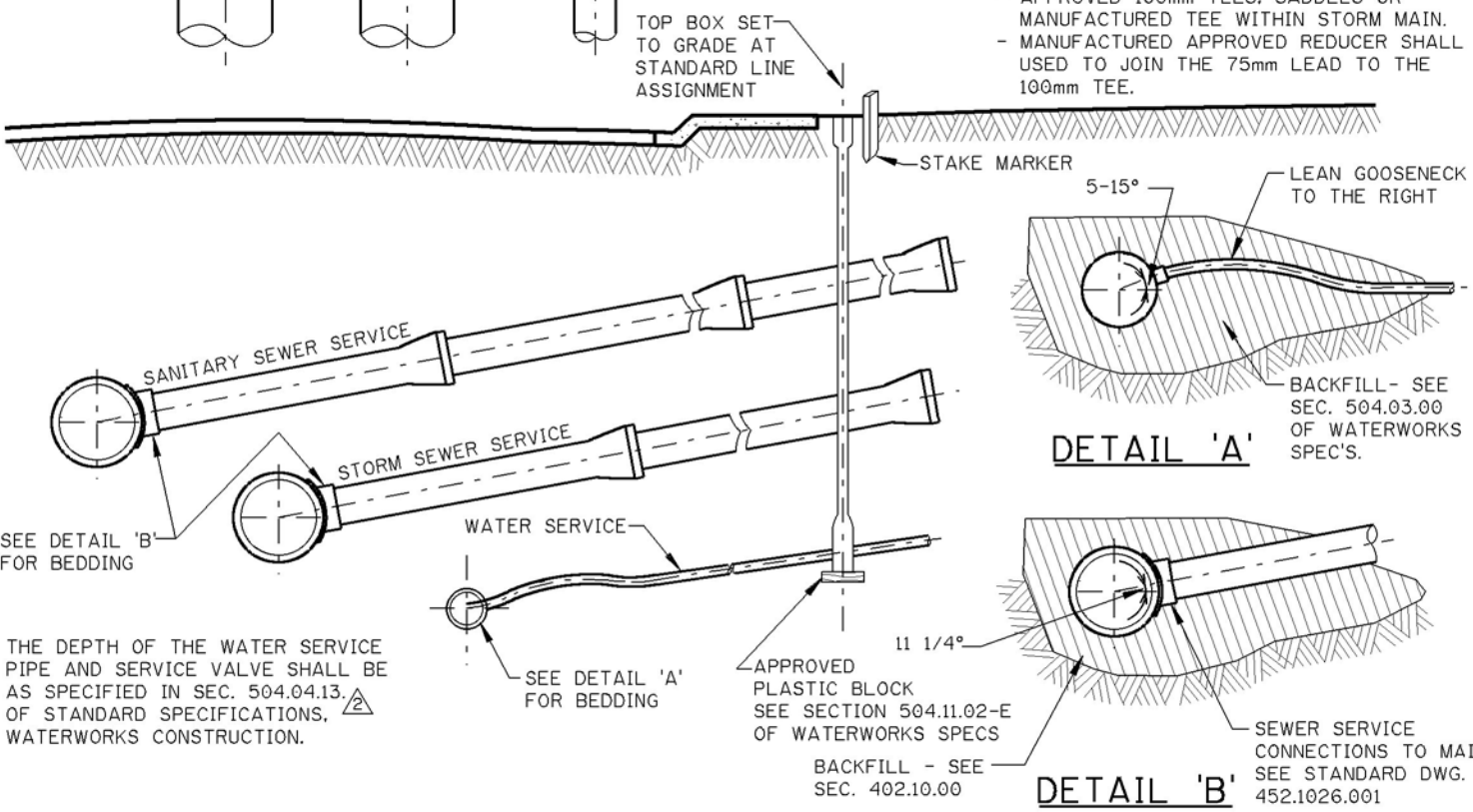

THE DEPTH OF THE WATER SERVICE PIPE AND SERVICE VALVE SHALL BE AS SPECIFIED IN SEC. 504.04.13. OF STANDARD SPECIFICATIONS, ² WATERWORKS CONSTRUCTION.

DIMENSIONS ARE IN MILLIMETRES UNLESS OTHERWISE NOTED

No.	Date	Revision	App'd
3	2015/04/22	ADDED SECOND - SINGLE SERVICE	EV
2	2004/11/01	SEC. REVISED FROM 504.04.12 TO 504.04.13	
1	2004/11/01	GENERAL REVISION	

Date
1999/09/14
Scale
N.T.S.
Approved by

for The City of Calgary

SEWER CONSTRUCTION

TYPICAL RESIDENTIAL SERVICE INTALLATION

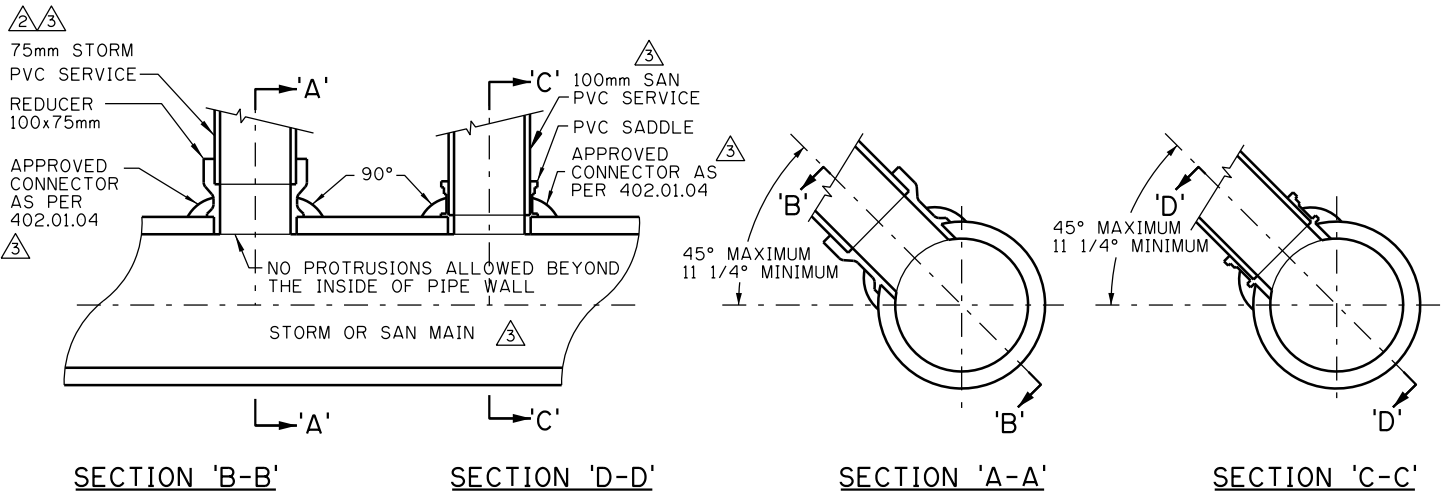
Sheet
34
File Number
452.1025.001



TYPICAL RESIDENTIAL ($\leq 100\text{mm}$) CONNECTIONS

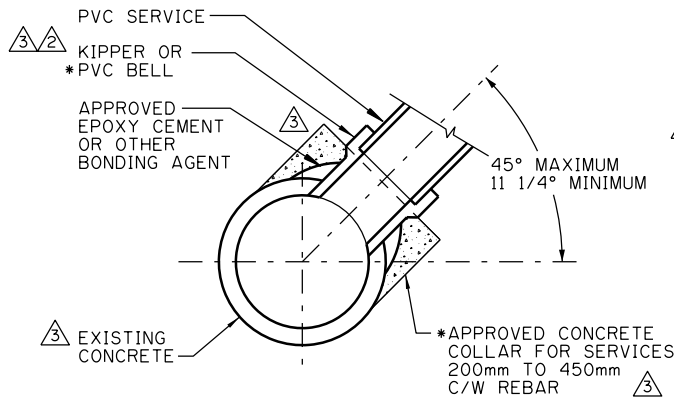

CROSS SECTION OF A TYPICAL EXISTING CONCRETE CONNECTION

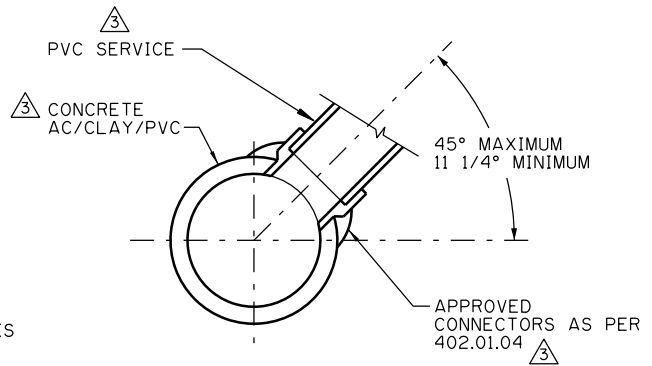

CROSS SECTION OF A TYPICAL CONNECTION

NOTES:

1. ALL FIELD CONNECTIONS TO BE CORED OUT.
2. THE VERTICAL TAPPING ANGLE MAY BE REDUCED TO 5° IF APPROVED BY THE ENGINEER.

TYPICAL DIRECT TO MAIN LARGE SERVICE CONNECTIONS

PERMITTED WHERE SERVICE SIZE $\leq 50\%$ OF MAIN SIZE
UP TO AND INCLUDING 900mm MAIN

DIMENSIONS ARE IN MILLIMETRES
UNLESS OTHERWISE NOTED

No.	Date	Revision
3	2020/02/04	REMOVED DETAIL, REVISED NOTES AND DETAIL
2	2017/02/09	REVISED NOTES AND DETAIL TITLE
1	2004/01/10	ADDED NOTE

Date 1999/09/14	
Scale N.T.S.	
Approved by 	for The City of Calgary

SEWER CONSTRUCTION
SEWER SERVICE CONNECTIONS TO MAINS

Sheet 35
File Number 452.1026.001

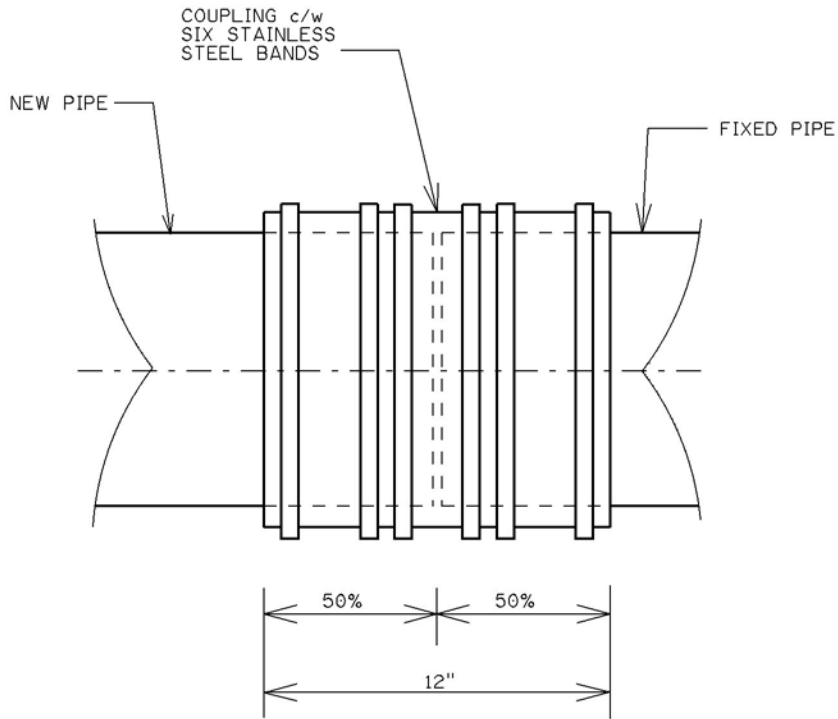

PIPE INSERTION INTO COUPLING AND BANDING

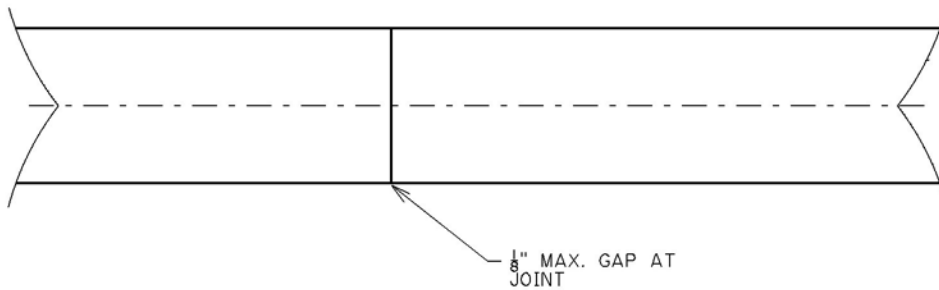

WELL FITTED PIPE JOINT

NOTES:

SEE DETAILED SPECIFICATIONS 403.05.06
PE (POLYETHYLENE) PIPE BURSTING PROCEDURES
FOR SANITARY SERVICES

DIMENSIONS ARE IN MILLIMETRES
UNLESS OTHERWISE NOTED

No.	Date	Revision	App'd
1	2006/09/18	NOTE ADDED	

Date
2002/09/16

Scale
N.T.S.

Approved by
[Signature]

for The City of Calgary



SEWER CONSTRUCTION

PE PIPE BURSTING
(SAN SERVICE REPL)
12" LONG COUPLING

Sheet
35A

File Number
452.1048.002

TRANSITION
COUPLING c/w
FOUR STAINLESS
STEEL BANDS

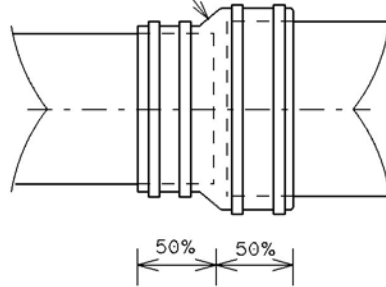

PIPE INSERTION INTO COUPLING

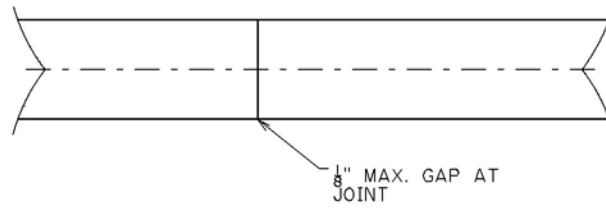

WELL FITTED PIPE JOINT

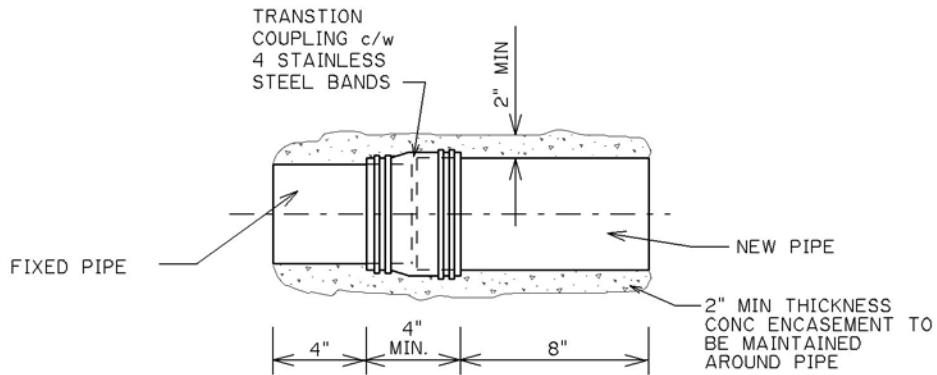

MIN TOTAL ENCASEMENT LENGTH

NOTE:

SEE DETAILED SPECIFICATIONS 403.05.06 PE (POLYETHYLENE)
PIPE BURSTING PROCEDURES FOR SANITARY SERVICES

DIMENSIONS ARE IN MILLIMETRES
UNLESS OTHERWISE NOTED

No.	Date	Revision	App'd
1	2006/09/18	NOTE ADDED	

Date
2002/09/16

Scale
N.T.S.

Approved by
[Signature]

For The City of Calgary



SEWER CONSTRUCTION

PE PIPE BURSTING (SAN
SERVICE REPL) 4" LONG
TRANSITION COUPLING

Sheet
35B

File Number
452.1048.001

NOTE:

BACKFILLING & COMPACTION SHALL BE DONE IN SEQUENCE FROM THE LOWEST UTILITY TO THE HIGHEST AT INCREMENTAL LIFTS OF 150mm.

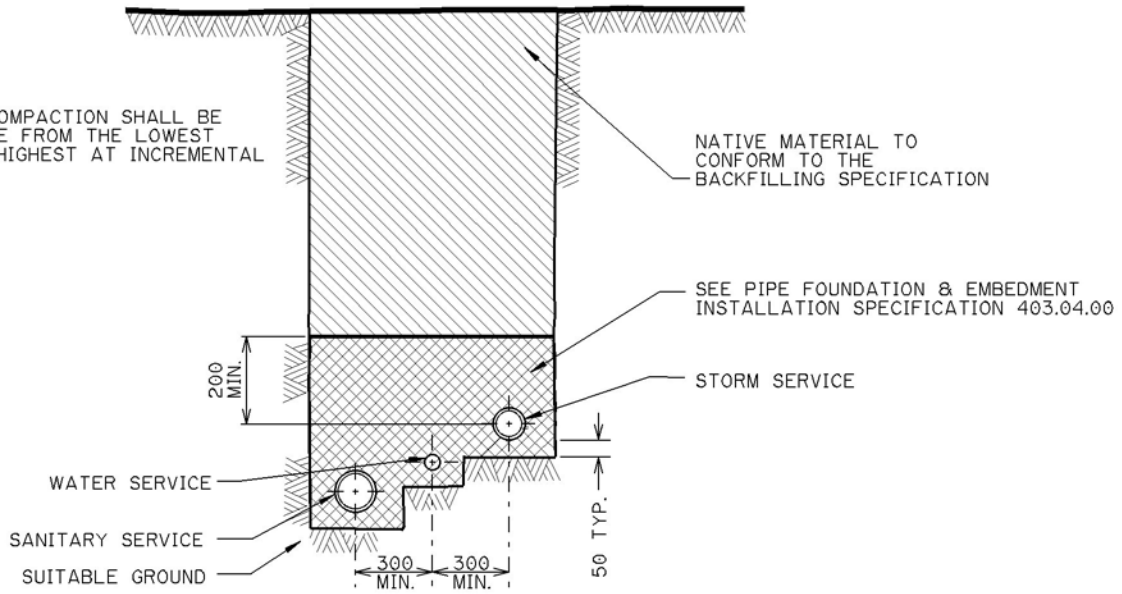

**SERVICES AT DIFFERENT ELEVATIONS
IN SUITABLE GROUND**

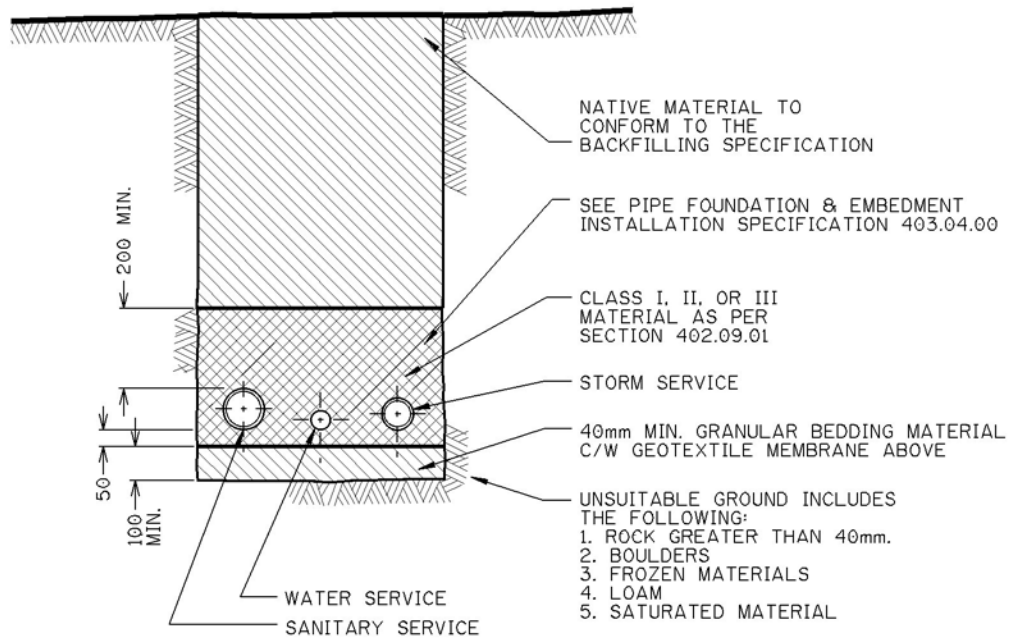

SERVICES IN UNSUITABLE GROUND

DIMENSIONS ARE IN MILLIMETRES
UNLESS OTHERWISE NOTED

No.	Date	Revision	App'd
3	2008/11/01	CHANGED DEPTH OF BEDDING	
2	2005/10/05	SECTION REFERENCE CORRECTED	
1	2004/11/22	MODIFIED TRENCH & GENERAL REVISIONS	

Date
1999/09/14
Scale
N.T.S.
Approved by
[Signature]
for The City of Calgary

SEWER CONSTRUCTION
**STANDARD BACKFILLING
FOR SERVICES**

Sheet
36
File Number
452.1005.002

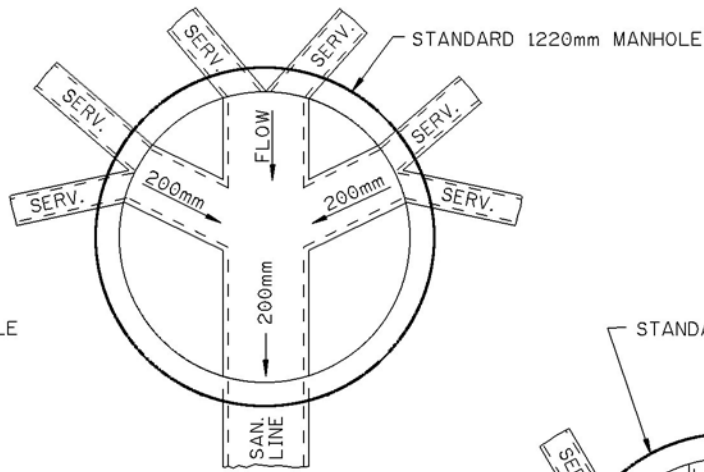

TYPICAL

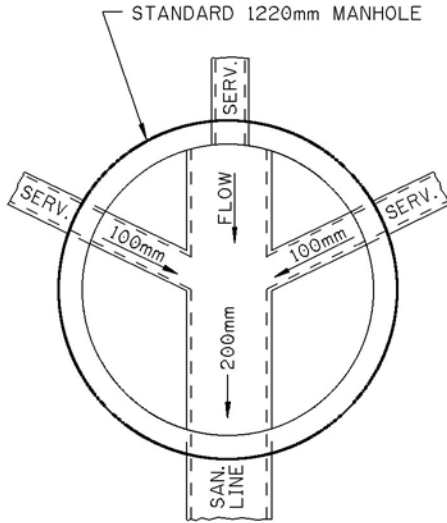

ALTERNATE #1

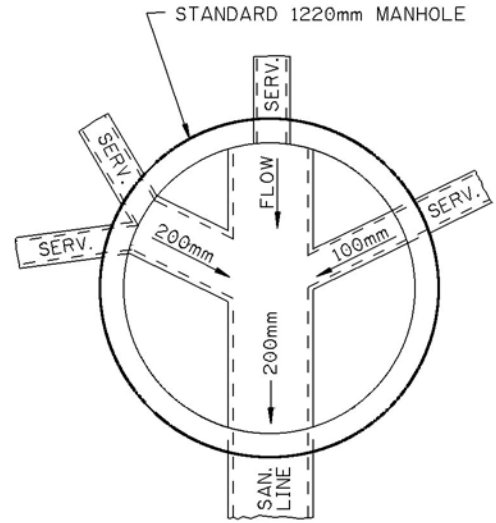

ALTERNATE #2

NOTE:

1. IN THE CASE OF MORE THAN 6 CONNECTIONS INTO A MANHOLE, A DETAIL DRAWING SHALL BE SUBMITTED TO THE ENGINEER FOR APPROVAL.
2. SEWER MAIN TO GO STRAIGHT THROUGH MANHOLE WITH 0.50 PIPE TO OPPOSITE WALL.
- 3a. MAXIMUM HEIGHT - INVERT OF INCOMING SERVICE PIPES SHALL NOT EXCEED 300mm ABOVE THE INVERT OF THE OUTLET MAIN LINE PIPE.
- 3b. MINIMUM HEIGHT - MATCH CROWN OF SERVICE PIPES WITH CROWN OF OUTLET MAIN LINE PIPE.
4. 0.50 PIPE BENCHING TO ACCOMMODATE BRANCH CONNECTIONS.
5. SERVICE CONNECTIONS INTO BARREL TO BE MACHINE CORED.
6. MIN. 100 FOR 1 SERVICE, MIN 200 FOR 2 SERVICES

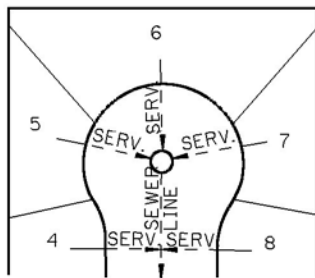

ALTERNATE #1

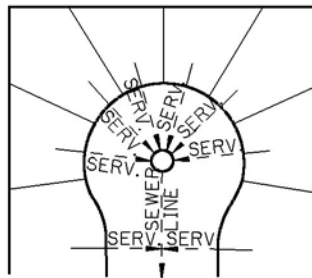

TYPICAL

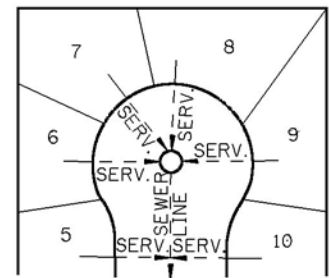

ALTERNATE #2

DIMENSIONS ARE IN MILLIMETRES UNLESS OTHERWISE NOTED

No.	Date	Revision
3	2013/10/29	ADDED NOTE 3B
2	2013/04/04	CHANGED PIPE SIZE FOR SERVICE CONNECTION TO SANITARY MH
1	2007/08/23	REVISED NOTES ADD SERVICES TO TYPICAL

Date
1999/09/14
Scale
N.T.S.
Approved by
AS
for The City of Calgary

SEWER CONSTRUCTION
SERVICE CONNECTION DETAILS FOR SANITARY SEWER MANHOLE IN CUL-DE-SAC

Sheet
37
File Number
452.1001.016

MANHOLE COVER:

- USE STANDARD MANHOLE COVER AS PER DWG SHEET #1 (452.1001.012).
- USE GRATED MANHOLE COVER AS PER DWG SHEET #2 (452.1001.011) ONLY IF CONSTRUCTION DRAWINGS INDICATE.

MANHOLE FRAME RISER:

- USE MANHOLE FRAME RISER AS PER DWG SHEET #3 (452.1001.007).
- USE ONLY FOR FINAL ADJUSTMENTS TO GRADE.

MANHOLE FRAME:

- USE STANDARD OR SHALLOW MANHOLE FRAME AS PER DWG SHEET #4 (452.1001.013), #4A (452.1001.031) & #5 (452.1001.014).

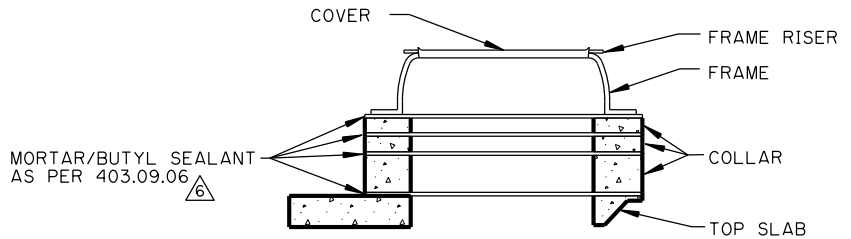

COLLAR DETAIL

NOTES:

1. AN ADDITIONAL STEP IS REQUIRED TO BE INSTALLED IF THE DISTANCE BETWEEN THE TOP STEP AND THE UNDERSIDE OF THE MANHOLE FRAME EXCEEDS 584mm. SPACING BETWEEN STEPS SHALL NOT BE LESS THAN 400mm.
2. MAXIMUM OF THREE COLLARS TO BE USED.

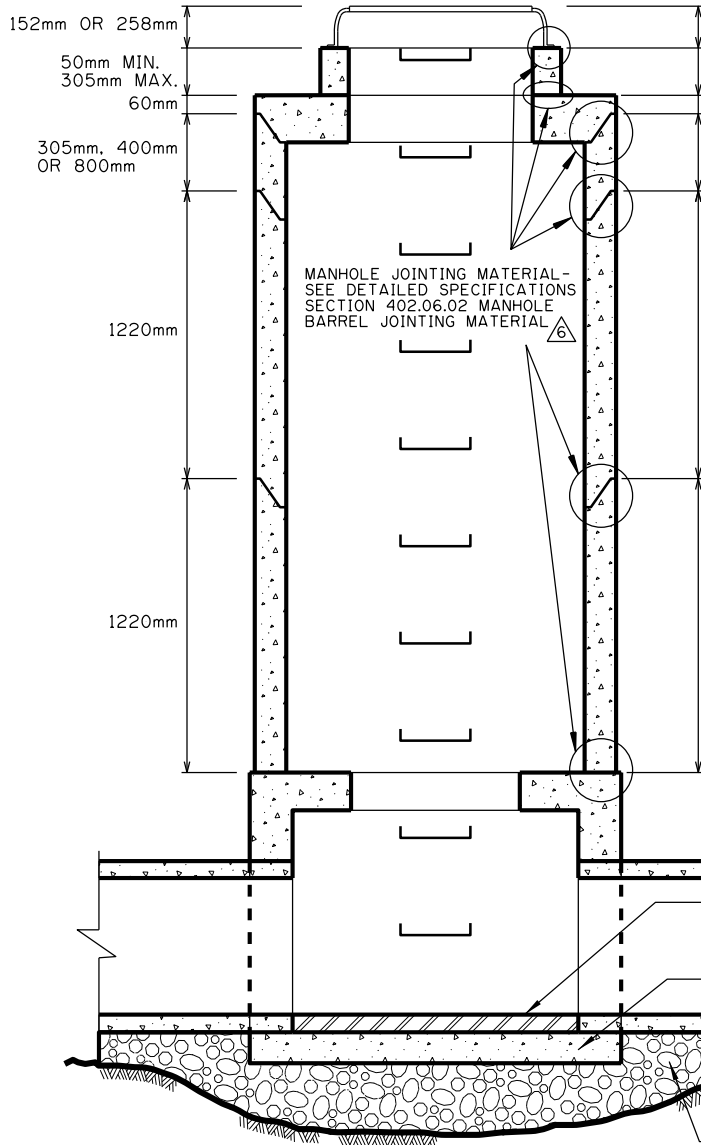

NOTES:

FOR TYPE '1' MANHOLES THE EXTENSION FROM THE TOP OF THE MANHOLE BASE TO SURFACE SHALL CONSIST OF A COMBINATION OF INTERMEDIATE & TOP BARRELS, TOP SLAB, COLLAR, MANHOLE FRAME AND COVER. MAXIMUM 2 (TWO) TOP BARRELS PER MANHOLE, IF REQUIRED.

DIMENSIONS ARE IN MILLIMETRES UNLESS OTHERWISE NOTED

No.	Date	Revision	M.C.
6	2020/02/04	REVISED NOTES	M.C.
5	2017/01/24	REVISED NOTES	M.C.
4	2014/08/01	REVISED NOTES	
3	2009/11/01	REVISED COLLAR NOTE	
2	2004/11/01	REVISED BEDDING NOTE	
1	2004/11/01	TEXT BARREL TYPE DELETED	

Date
1999/09/14
Scale
N.T.S.
Approved by
AS
for The City of Calgary

SEWER CONSTRUCTION
MANHOLE ASSEMBLY

Sheet
38
File Number
452.1001.023

MANHOLE COVER:

- USE STANDARD MANHOLE COVER AS PER DWG SHEET #1 (452.1001.012).
- USE GRATED MANHOLE COVER AS PER DWG SHEET #2 (452.1001.011) ONLY IF CONSTRUCTION DRAWINGS INDICATE.

MANHOLE FRAME RISER:

- USE MANHOLE FRAME RISER AS PER DWG SHEET #3 (452.1001.007).
- USE ONLY FOR FINAL ADJUSTMENTS TO GRADE.

MANHOLE FRAME:

- USE STANDARD OR SHALLOW MANHOLE FRAME AS PER DWG SHEET #4 (452.1001.013), #4A (452.1001.031) & #5 (452.1001.014).

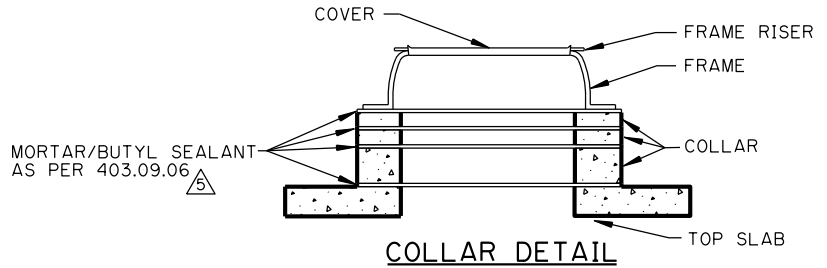

NOTES:

1. AN ADDITIONAL STEP IS REQUIRED TO BE INSTALLED IF THE DISTANCE BETWEEN THE TOP STEP AND THE UNDERSIDE OF THE MANHOLE FRAME EXCEEDS 584mm. SPACING BETWEEN STEPS SHALL NOT BE LESS THAN 400mm.
2. MAXIMUM OF THREE COLLARS TO BE USED.

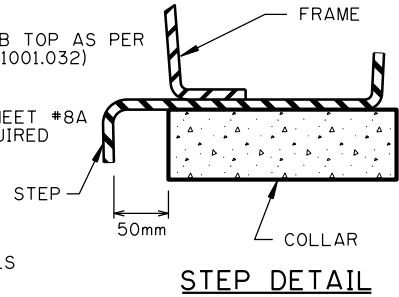
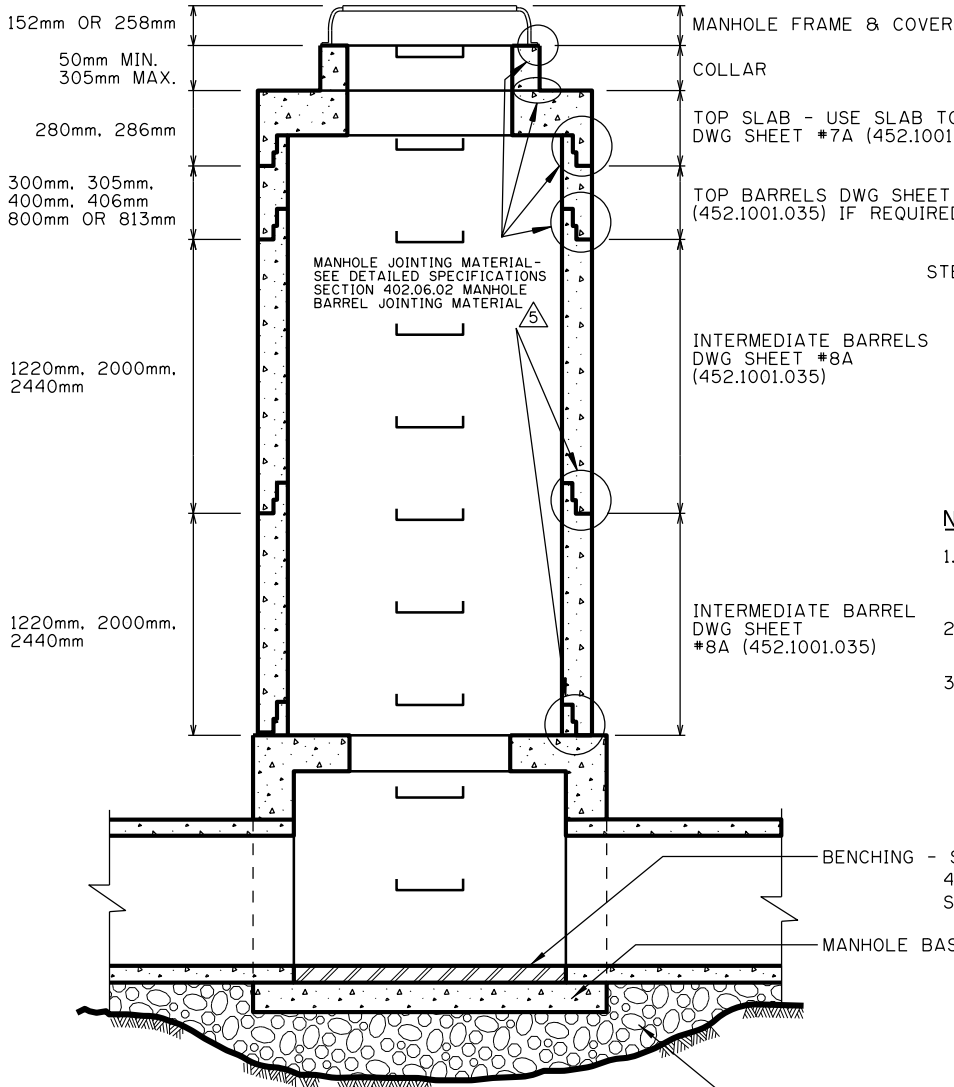

- MANHOLE STEP TO BE INSTALLED BETWEEN FRAME AND COLLAR

NOTES:

1. COLLAR - USE PRE-CAST CONCRETE COLLAR(S) AS PER DWG SHEET #6 (452.1001.006).
2. STEP - USE MANHOLE STEP AS PER DWG SHEET #9 (452.1001.021).
3. MORTAR - SEE DETAILED SPECIFICATIONS, SECTION 402.03.02 MORTAR.

BENCHING - SEE DETAILED SPECIFICATION 403.09.00 BENCHING & DWG SHEET #39 (452.1003.007)

MANHOLE BASE - USE MANHOLE BASES AS PER DWG SHEET #10, 11, 12, 13, 14, 15, 16, 17, 18, 19 & 20. (CITY STANDARDS)

BEDDING - SEE DETAILED SPECIFICATIONS 403.04.03 MANHOLE BEDDING

NOTES:

- FOR TYPE '1' MANHOLES THE EXTENSION FROM THE TOP OF THE MANHOLE BASE TO SURFACE SHALL CONSIST OF A COMBINATION OF INTERMEDIATE & TOP BARRELS, TOP SLAB, COLLAR, MANHOLE FRAME AND COVER. MAXIMUM 2 (TWO) TOP BARRELS PER MANHOLE, IF REQUIRED.

DIMENSIONS ARE IN MILLIMETRES UNLESS OTHERWISE NOTED

<table border="1"> <tr> <td>5</td> <td>2020/02/04</td> <td>REVISED NOTE</td> <td>M.C.</td> </tr> <tr> <td>4</td> <td>2017/01/24</td> <td>REVISED NOTE</td> <td>M.C.</td> </tr> <tr> <td>3</td> <td>2014/08/01</td> <td>REVISED COLLAR NOTE</td> <td></td> </tr> <tr> <td>2</td> <td>2009/11/01</td> <td>REVISED COLLAR NOTE</td> <td></td> </tr> <tr> <td>1</td> <td>2004/11/01</td> <td>REVISED SHEET NUMBER</td> <td></td> </tr> </table>		5	2020/02/04	REVISED NOTE	M.C.	4	2017/01/24	REVISED NOTE	M.C.	3	2014/08/01	REVISED COLLAR NOTE		2	2009/11/01	REVISED COLLAR NOTE		1	2004/11/01	REVISED SHEET NUMBER		<table border="1"> <tr> <td>Date</td> <td>2004/08/27</td> </tr> <tr> <td>Scale</td> <td>N.T.S.</td> </tr> <tr> <td>Approved by</td> <td><i>MS</i></td> </tr> <tr> <td></td> <td>for The City of Calgary</td> </tr> </table>	Date	2004/08/27	Scale	N.T.S.	Approved by	<i>MS</i>		for The City of Calgary	<table border="1"> <tr> <td colspan="2">SEWER CONSTRUCTION</td> </tr> <tr> <td colspan="2">MANHOLE ASSEMBLY FOR SPIGOT-UP INSTALLATIONS</td> </tr> </table>	SEWER CONSTRUCTION		MANHOLE ASSEMBLY FOR SPIGOT-UP INSTALLATIONS		<table border="1"> <tr> <td>Sheet</td> <td>38A</td> </tr> <tr> <td>File Number</td> <td>452.1001.037</td> </tr> </table>	Sheet	38A	File Number	452.1001.037
5	2020/02/04	REVISED NOTE	M.C.																																					
4	2017/01/24	REVISED NOTE	M.C.																																					
3	2014/08/01	REVISED COLLAR NOTE																																						
2	2009/11/01	REVISED COLLAR NOTE																																						
1	2004/11/01	REVISED SHEET NUMBER																																						
Date	2004/08/27																																							
Scale	N.T.S.																																							
Approved by	<i>MS</i>																																							
	for The City of Calgary																																							
SEWER CONSTRUCTION																																								
MANHOLE ASSEMBLY FOR SPIGOT-UP INSTALLATIONS																																								
Sheet	38A																																							
File Number	452.1001.037																																							

MANHOLE COVER:

- △ USE STANDARD MANHOLE COVER AS PER DWG SHEET #1 (452.1001.012).
- △ USE GRATED MANHOLE COVER AS PER DWG SHEET #2 (452.1001.011) ONLY IF CONSTRUCTION DRAWINGS INDICATE.

MANHOLE FRAME RISER:

- △ USE MANHOLE FRAME RISER AS PER DWG SHEET #3 (452.1001.007).
- △ USE ONLY FOR FINAL ADJUSTMENTS TO GRADE.

MANHOLE FRAME:

- △ USE STANDARD OR SHALLOW MANHOLE FRAME AS PER DWG SHEET #4 (452.1001.013), #4A (452.1001.031) & #5 (452.1001.014).

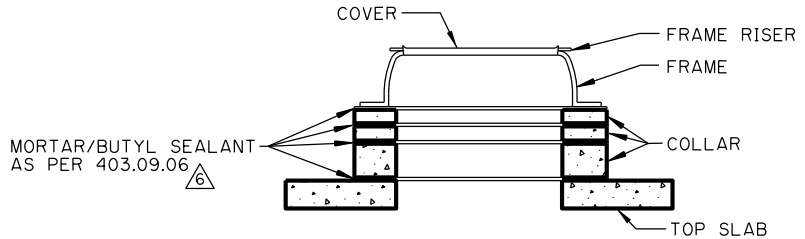

COLLAR DETAIL

NOTES:

1. AN ADDITIONAL STEP IS REQUIRED TO BE INSTALLED IF THE DISTANCE BETWEEN THE TOP STEP AND THE UNDERSIDE OF THE MANHOLE FRAME EXCEEDS 584mm. SPACING BETWEEN STEPS SHALL NOT BE LESS THAN 400mm.
- △ 2. MAXIMUM OF THREE COLLARS TO BE USED.

MANHOLE FRAME & COVER COLLAR

TOP SLAB
DWG SHEET #7A (452.1001.032)

TOP BARRELS
DWG SHEET #8A (452.1001.035)
MAX. 2 (TWO) PER MH IF REQUIRED

INTERMEDIATE BARREL
DWG SHEET #8A (452.1001.035)

INTERMEDIATE BARREL
DWG SHEET #8A (452.1001.035)

PREBENCH BASE

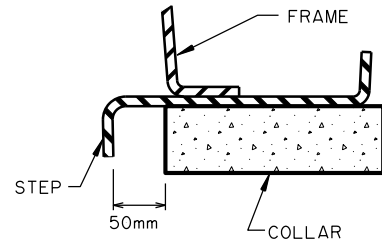
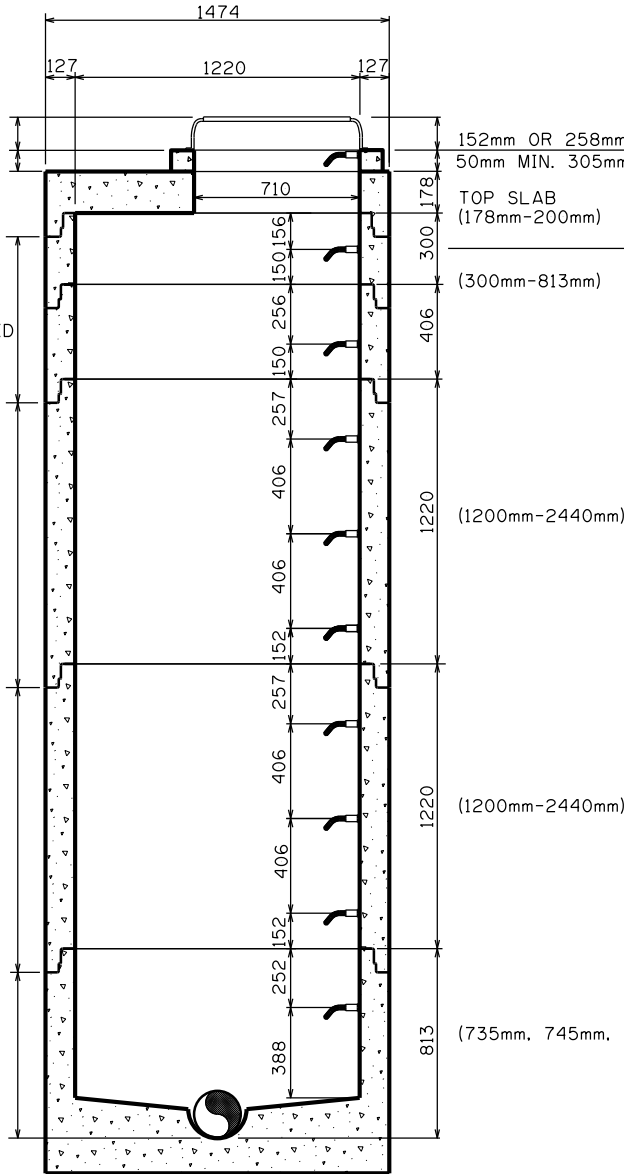

STEP DETAIL

- MANHOLE STEP TO BE INSTALLED BETWEEN FRAME AND COLLAR

NOTES:

1. COLLAR - USE PRE-CAST CONCRETE COLLAR(S) AS PER DWG SHEET #6 (452.1001.006).
2. STEP - USE MANHOLE STEP AS PER DWG SHEET #9 (452.1001.021).
3. MORTAR - SEE DETAILED SPECIFICATIONS. SECTION 402.03.02 MORTAR.

MATERIAL SPECIFICATIONS:

- △ 1. HS 50 CEMENT (TYPE 50).
- 2. DESIGN AND REINFORCING AS PER ASTM 478M & CSA A257.4.

DIMENSIONS ARE IN MILLIMETRES UNLESS OTHERWISE NOTED

6	2020/02/05	REVISED NOTE	M.C.	Date	2004/11/03		SEWER CONSTRUCTION	Sheet 38B
5	2017/01/24	REVISED NOTE	M.C.	Scale	N.T.S.			
4	2014/08/01	ADDED NOTES AND DETAILS		Approved by		5A MANHOLE ASSEMBLY FOR SPIGOT-UP INSTALLATIONS	File Number 452.1001.036	
3	2009/11/01	ADDED COLLAR DETAIL AND NOTE		for The City of Calgary				
2	2008/10/01	ADDED BASE SIZES						
1	2005/10/01	TYPE 50 CEMENT CHANGED TO TYPE HS CEMENT (TYPE 50)						
No.	Date	Revision	App'd					

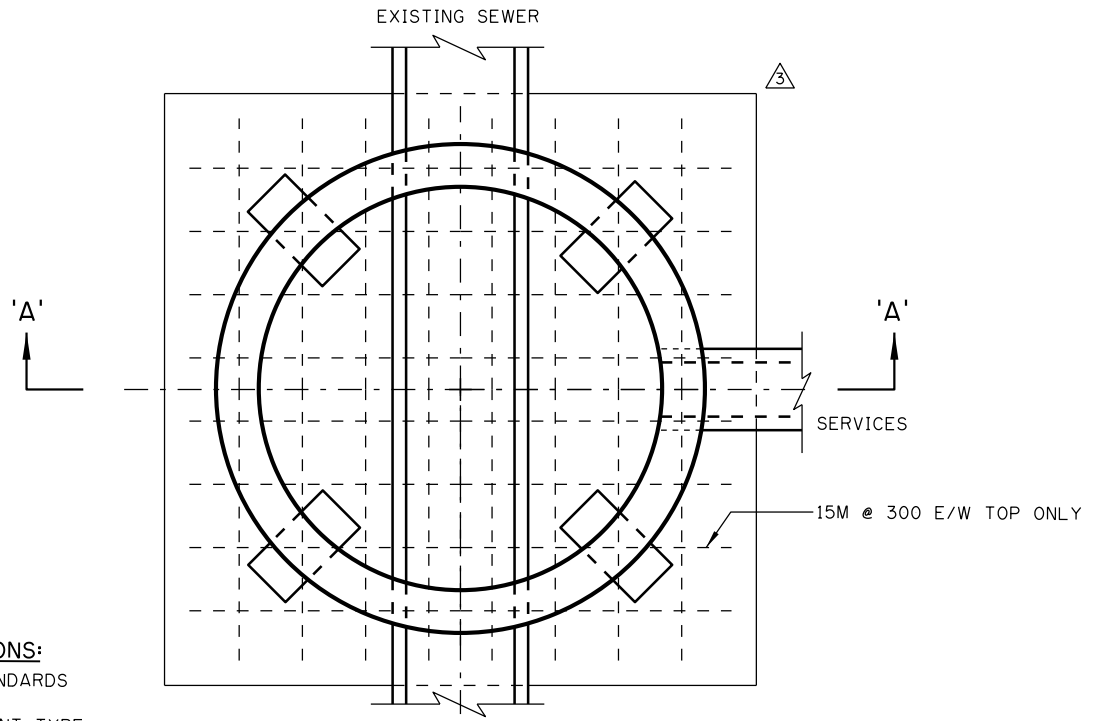

PLAN VIEW

MATERIAL SPECIFICATIONS:

(ALL SPECIFICATIONS & STANDARDS REFER TO LATEST EDITION)

1. CEMENT: SULFATE RESISTANT TYPE: TYPE HS (TYPE 50) TO CSA 3001 OR TYPE V TO ASTM C150
2. CONCRETE COMPRESSIVE STRENGTH: 35 MPa AT 28 DAYS
3. AIR CONTENT: 4% TO 7% EXCEPT WHERE NO-SLUMP CONCRETE IS USED
4. REINFORCING STEEL : DEFORMED BARS TO CSA G30.18, fy = 400 MPa

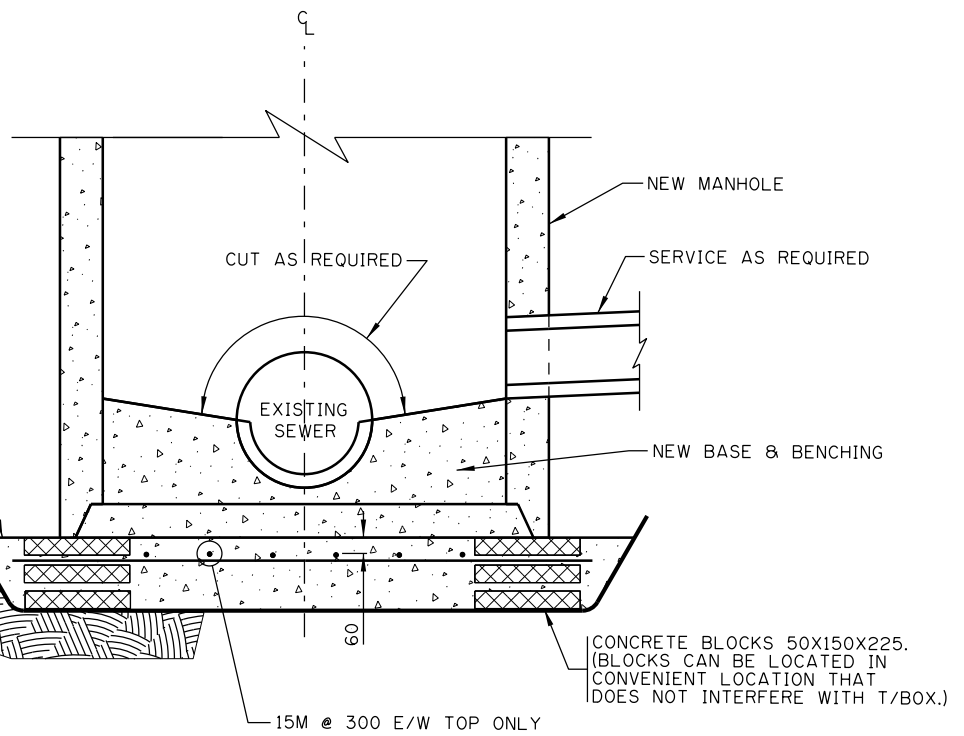

SECTION 'A-A'

**EXISTING SEWER
ADD MANHOLE FOR SERVICE**

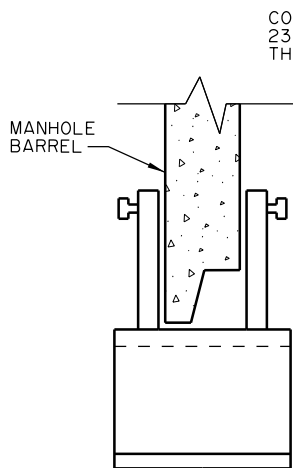

ALTERNATE STEEL SHIM

NOTE: THIS INSTALLATION REQUIRES PRIOR APPROVAL FROM WATER RESOURCES.

DIMENSIONS ARE IN MILLIMETRES UNLESS OTHERWISE NOTED

No.	Date	Revision
3	2020/02/10	CONCRETE STRENGTH REVISED. DETAIL MODIFIED
2	2015/11/30	REVISED NOTE
1	2005/10/01	WASTEWATER CHANGED TO WATER SERVICES

Date
2005/01/25

Scale
N.T.S.

Approved by

for The City of Calgary

SEWER CONSTRUCTION

NEW '5A' MANHOLE
ON EXISTING SEWER

Sheet
38C

File Number
452.1001.044

1. BENCHING IN MANHOLES

△ HALF, 3/4 PIPE OR APPROVED EQUAL

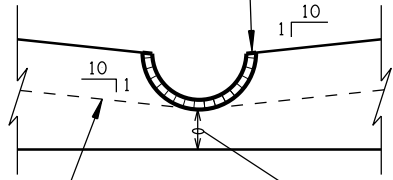

- △ - STANDARD MINIMUM SIDE SLOPE OF BENCHING 10:1 FROM HALF OR 3/4 WAY UP PIPE IN ALL CASES.
- △1 - ALL CONCRETE SHALL BE 30MP_a IN 28 DAYS.
- SANITARY - HALF PIPE OR APPROVED EQUAL SHALL FORM THE INVERT.
- STORM - SAME BENCHING AS SANITARY FOR PIPE DIAMETER LESS THAN OR EQUAL TO 600mm.
- △3 - ALL CHANNELS ARE TO BE SIZE ON SIZE. CHANNELS ONE PIPE SIZE LARGER WILL BE ACCEPTED.
- △4 - ALL UNUSED CHANNELS ON PRE-BENCHED MANHOLES THAT ARE NOT INTENDED FOR FUTURE EXPANSIONS ARE TO BE FILLED WITH CONCRETE AS DESCRIBED IN 403.09.04 BENCHING.

MINIMUM OF 100mm VERY LOW SLUMP SULPHATE RESISTANT CONCRETE.
STORM BENCHING ON PIPE DIAMETER GREATER THAN 600mm AND ALL SKIMMING MANHOLES.

2. MATCH CROWNS (MINIMUM) WHEN INCOMING PIPE DIA. IS SMALLER THAN OUTGOING PIPE DIA. OR PIPE CROWN TO BE 60mm OR GREATER ABOVE OUTGOING PIPE CROWN WHEN INCOMING PIPE DIA. EQUALS OUTGOING PIPE DIA.

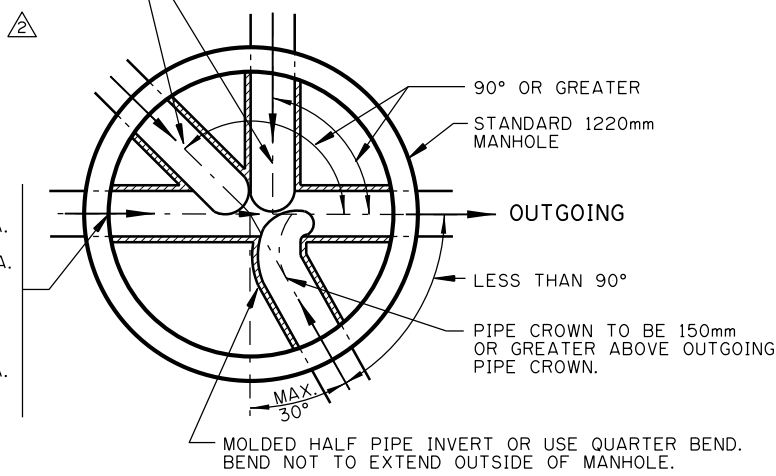

- LOWEST OR OUTGOING PIPE TO GO STRAIGHT THROUGH MANHOLE WITH HALF PIPE TO OPPOSITE WALL IN ALL CASES INCLUDING DEAD END MANHOLE.
- WHERE THE ANGLE BETWEEN THE DIRECTION OF FLOW IN THE INCOMING AND OUTGOING PIPES IS 90° OR GREATER, THEN THE INCOMING PIPE MUST COME STRAIGHT TO INTERSECT WITH THE OUTGOING PIPE WITH A HALF PIPE SET IN MAIN BENCHING; WHERE THIS ANGLE IS LESS THAN 90°, THEN A MINIMUM OF 150mm DROP IS REQUIRED BETWEEN INCOMING AND OUTGOING INVERTS.
- USE OF PRE-BENCHED OR ON-SITE CONSTRUCTED SWEEP CHANNELS PERMITTED IN DIRECTION OF MAIN FLOW. △

3. CASE I

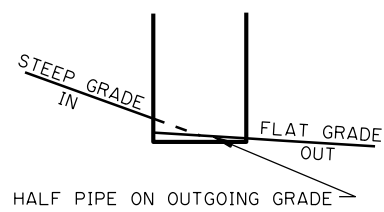

CASE II

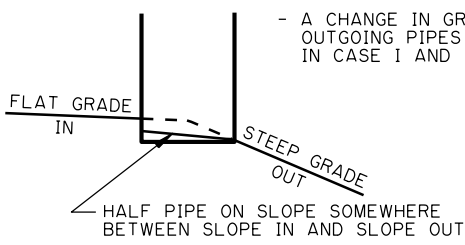

- A CHANGE IN GRADE BETWEEN INCOMING AND OUTGOING PIPES MAY BE ACCOMPLISHED AS SHOWN IN CASE I AND II.

4. SANITARY SEWERS

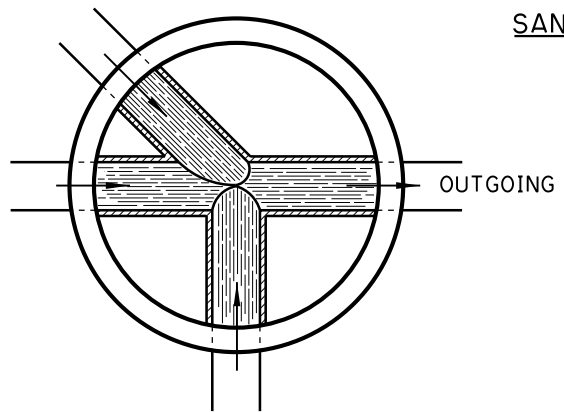

NOTES:

1. USE SANITARY DROP MANHOLE WHEN INCOMING PIPE INVERT IS 760mm OR GREATER ABOVE OUTGOING PIPE CENTERLINE. FOR DETAIL OF MANHOLE, SEE SHEET #14 & #15.
2. HAVE INLET FLOW DROP INTO HALF PIPE SET IN MAIN BENCHING AND RUNNING STRAIGHT TO INTERSECTION WITH OUTGOING PIPE.
- △3. HALF OR 3/4 PIPE STRAIGHT THROUGH ON OUTGOING SLOPE.

DIMENSIONS ARE IN MILLIMETRES UNLESS OTHERWISE NOTED

No.	Date	Revision	App'd	Date	Scale	Approved by	for The City of Calgary	SEWER CONSTRUCTION	Sheet	39	File Number	452.1003.007
5	2020/02/05	REVISED & ADDED NOTES		1999/09/14	N.T.S.							
4	2017/01/13	ADDED NOTE IN SECTION 1										
3	2014/08/01	ADD NOTE IN SECTION 1										
2	2012/01/01	REVISE & ADDED NOTES										
1	2004/11/01	CHANGE CONCRETE STRENGTH										

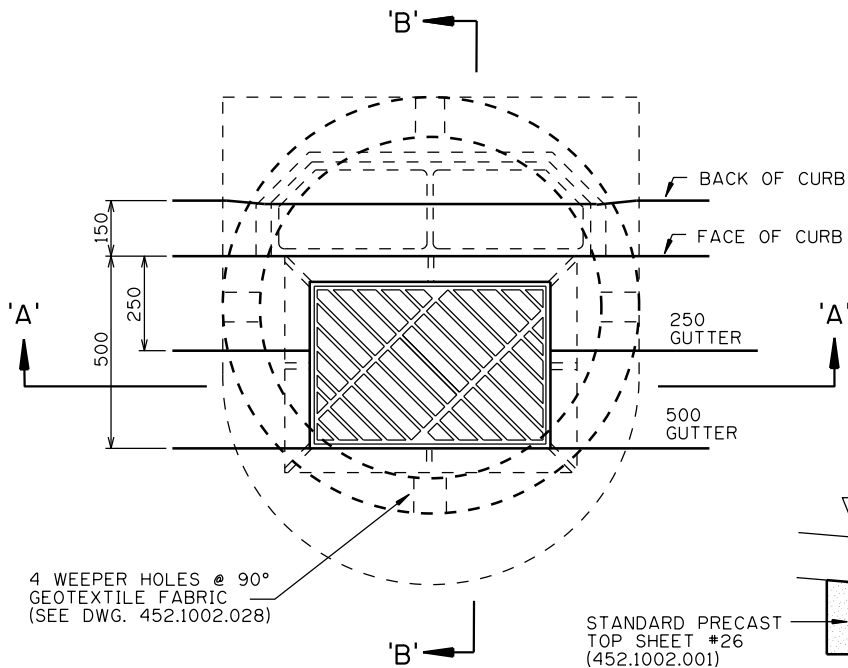

PLAN

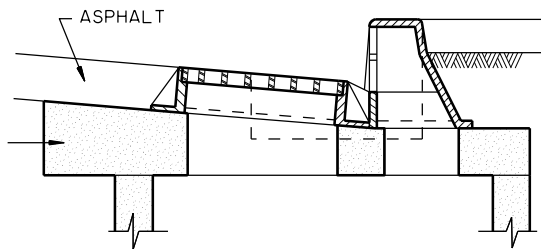

SECTION 'B-B'

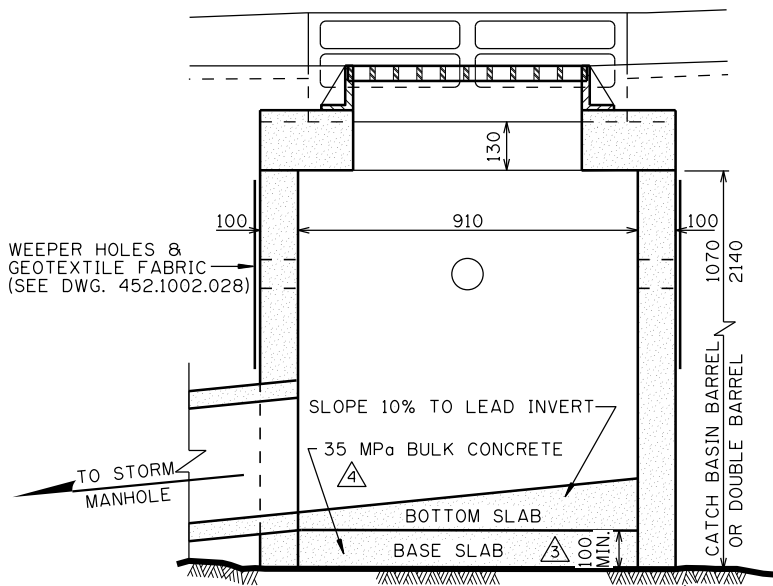

SECTION 'A-A'

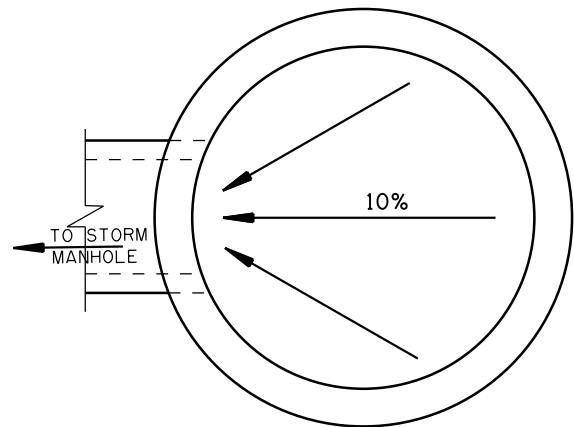

PLAN OF BOTTOM SLAB

NOTE:

- PRECAST CATCH BASIN BARRELS TO CONFORM TO A.S.T.M. C-478 (LATEST EDITION)
- ALTERNATE PRECAST CATCH BASIN BASE.
- SEE SHEET 31A

DIMENSIONS ARE IN MILLIMETRES UNLESS OTHERWISE NOTED

No.	Date	Revision	App'd
4	2020/06/01	REVISED NOTES	D.N.
3	2015/11/18	REVISED SPEC NUMBER & MOVE DIM TO BASE SLAB	M.C.
2	2007/08/01	REVISED SECTION A-A BEDDING NOTE	
1	2004/11/01	CHANGE CONCRETE STRENGTH	

Date
1999/09/14

Scale
N.T.S.

Approved by
[Signature]

for The City of Calgary

SEWER CONSTRUCTION

STORM CATCH BASIN
TYPE 'C' ASSEMBLY

Sheet
40

File Number
452.1002.004

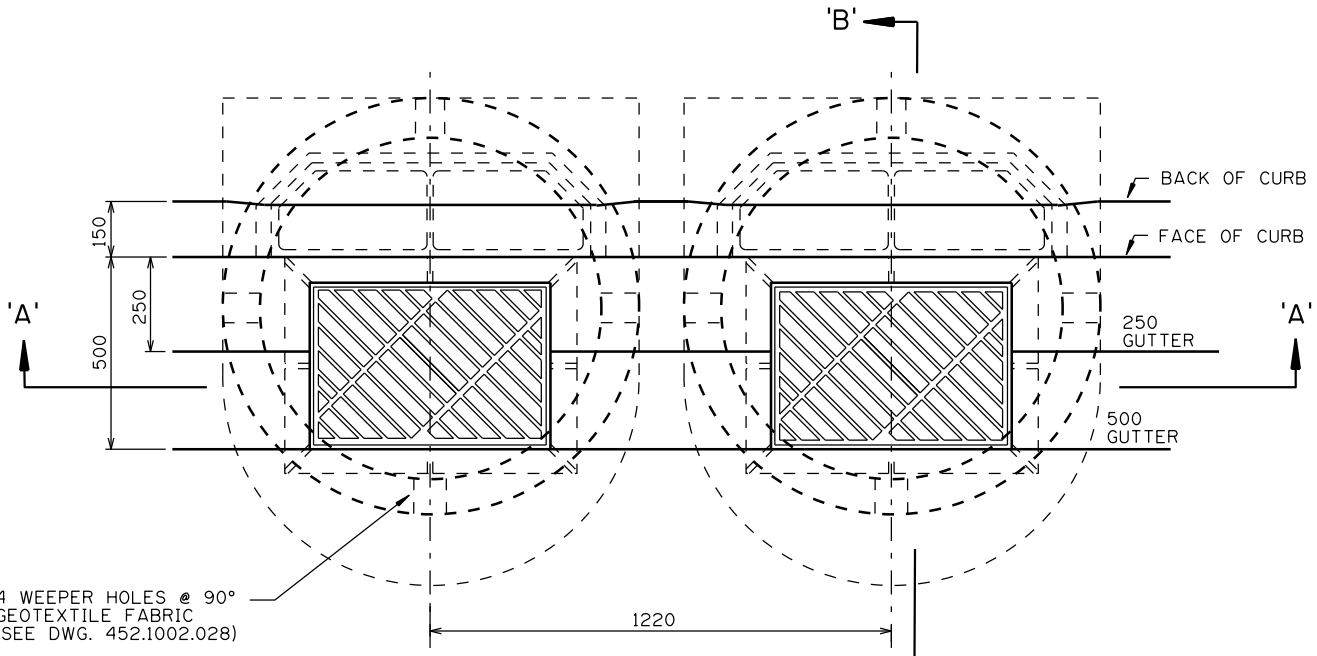

PLAN

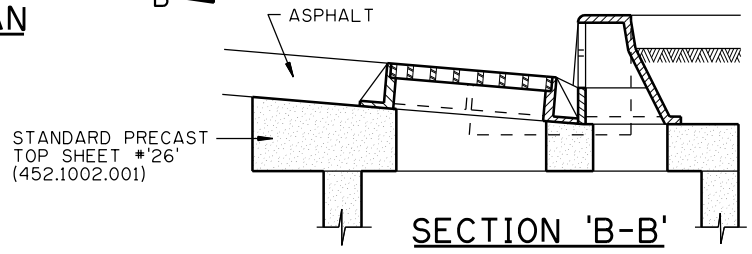

SECTION 'B-B'

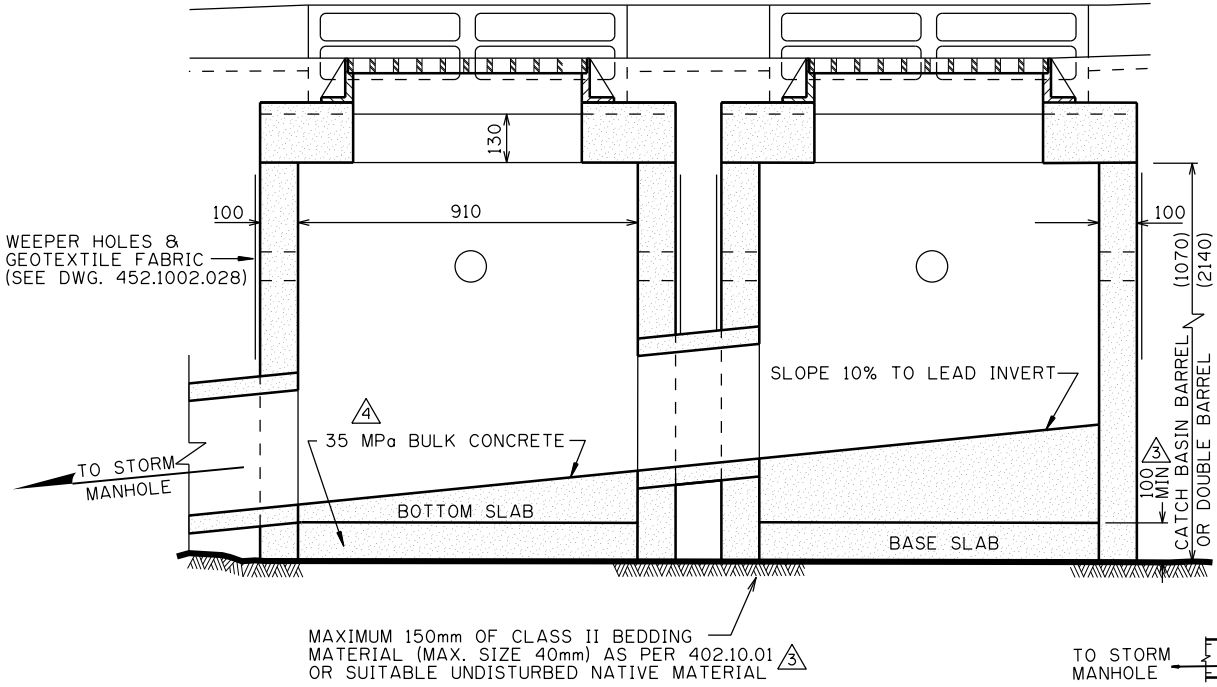

SECTION 'A-A'

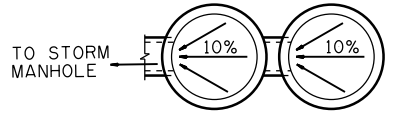

PLAN OF BOTTOM SLAB

NOTE:
 -PRECAST CATCH BASIN BARRELS TO CONFORM TO A.S.T.M. C-478 (LATEST EDITION)
 -ALTERNATE PRECAST CATCH BASIN BASE.
 -SEE SHEET 31A

DIMENSIONS ARE IN MILLIMETRES UNLESS OTHERWISE NOTED

Date		1999/09/14			SEWER CONSTRUCTION	Sheet	41
Scale		N.T.S.					
Approved by				TWIN STORM CATCH BASINS TYPE 'C' ASSEMBLY		File Number	
No.		Date		Revision		452.1002.018	
4	2020/06/02	REVISED NOTES	D.N.				
3	2015/11/18	REVISED SPEC NUMBER	M.C.				
2	2007/08/01	REVISED SECTION A-A BEDDING NOTE					
1	2004/11/01	CHANGE CONCRETE STRENGTH					

4 WEEPER HOLES @ 90°
GEOTEXTILE FABRIC
(SEE DWG. 452.1002.028)

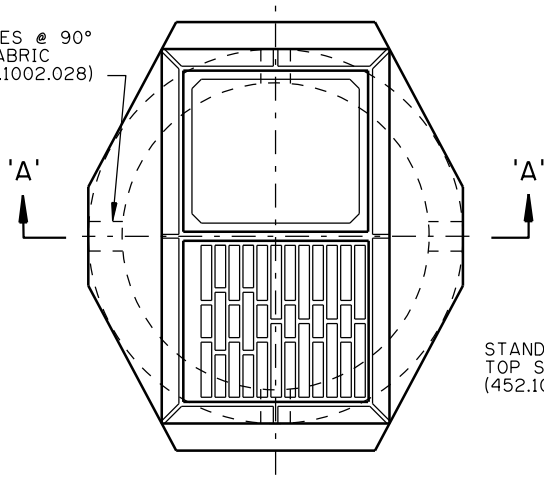

PLAN

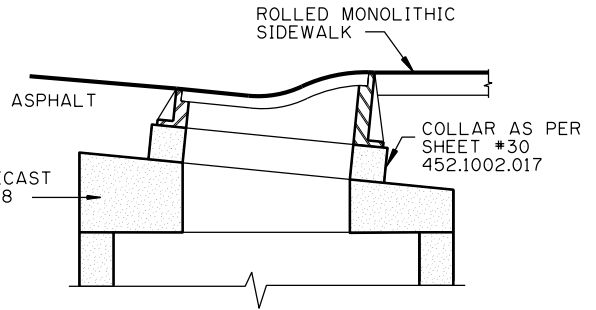

CATCH BASIN & SIDEWALK

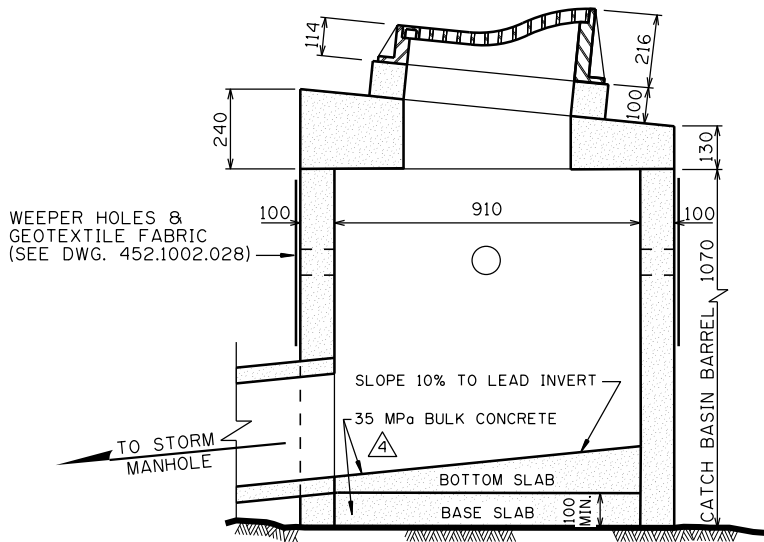

SECTION 'A-A'

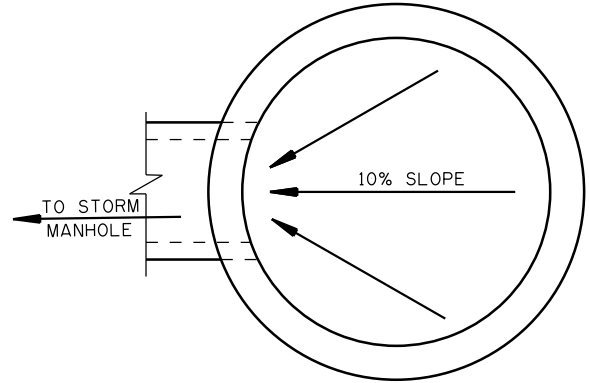

PLAN OF BOTTOM SLAB

MAXIMUM 150mm OF CLASS II BEDDING MATERIAL (MAX. SIZE 40mm) AS PER 402.10.01 OR SUITABLE UNDISTURBED NATIVE MATERIAL

NOTE:

- PRECAST CATCH BASIN BARRELS TO CONFORM TO A.S.T.M. C-478 (LATEST EDITION)
- ALTERNATE PRECAST CATCH BASIN BASE.
- SEE SHEET 31A

DIMENSIONS ARE IN MILLIMETRES UNLESS OTHERWISE NOTED

No.	Date	Revision	App'd
4	2020/06/02	REVISED NOTES	D.N.
3	2015/11/18	REVISED SPEC NUMBER	M.C.
2	2007/08/01	REVISED SECTION A-A BEDDING NOTE	
1	2004/11/01	CHANGE CONCRETE STRENGTH	

Date
1999/09/14

Scale
N.T.S.

Approved by
[Signature]

for The City of Calgary

SEWER CONSTRUCTION

STORM CATCH BASIN
TYPE 'K-2' ASSEMBLY

Sheet
42

File Number
452.1002.013

4 WEEPER HOLES @ 90°
GEOTEXTILE FABRIC
(SEE DWG. 452.1002.028)

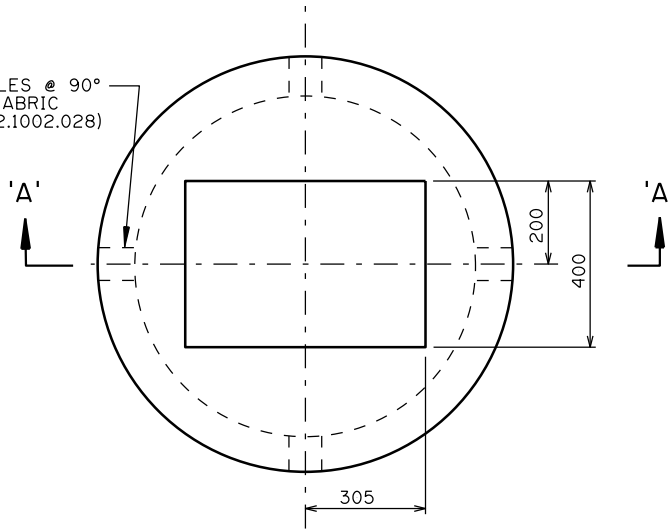

PLAN

PRECAST ROUND TOP-
SEE DWG. SHEET #29 (452.1002.020)

CATCH BASIN FRAME & GRATE
SEE DWG. SHEET #22 & 24
(452.1002.010 & .003)

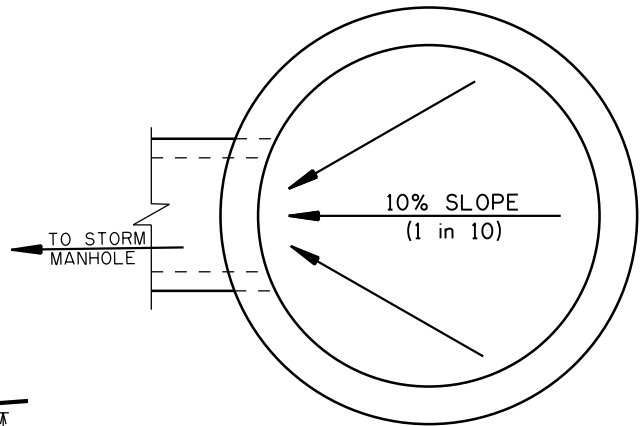

PLAN OF BOTTOM SLAB

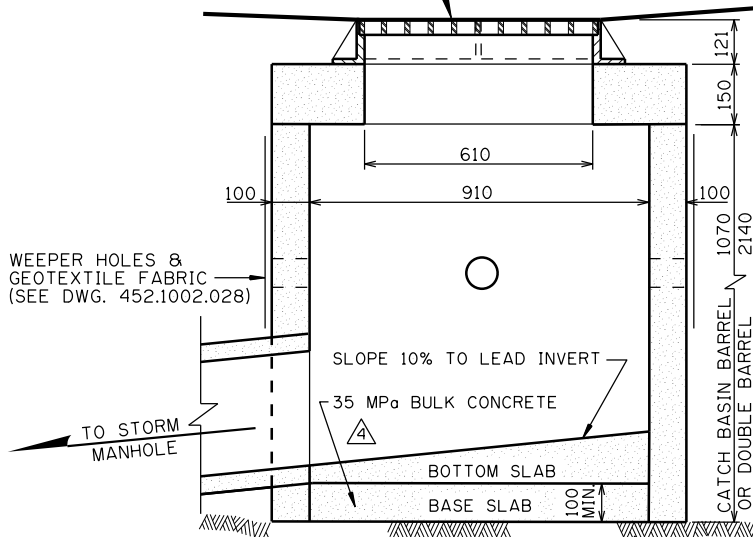

WEEPER HOLES &
GEOTEXTILE FABRIC
(SEE DWG. 452.1002.028)

SLOPE 10% TO LEAD INVERT

35 MPa BULK CONCRETE

BOTTOM SLAB

BASE SLAB

100 MIN

MAXIMUM 150mm OF CLASS II BEDDING
MATERIAL (MAX. SIZE 40mm) AS PER 402.10.01
OR SUITABLE UNDISTURBED NATIVE MATERIAL

NOTE:

- PRECAST CATCH BASIN BARRELS TO CONFORM TO A.S.T.M. C-478 (LATEST EDITION).
- ALTERNATE PRECAST CATCH BASIN BASE.
- SEE SHEET 31A

SECTION 'A-A'

DIMENSIONS ARE IN MILLIMETRES
UNLESS OTHERWISE NOTED

No.	Date	Revision
4	2020/06/02	REVISED NOTES
3	2015/11/18	REVISED SPEC NUMBER
2	2007/08/01	REVISED SECTION A-A BEDDING NOTE
1	2004/11/01	CHANGE CONCRETE STRENGTH

Date
1999/09/14

Scale
N.T.S.

Approved by
[Signature]

for The City of Calgary

SEWER CONSTRUCTION

STORM CATCH BASIN
TYPE 'K-3' ASSEMBLY

Sheet
43

File Number
452.1002.002

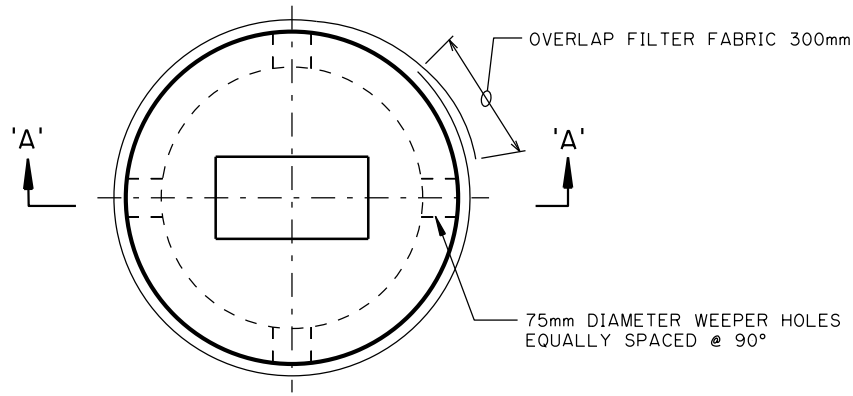

PLAN

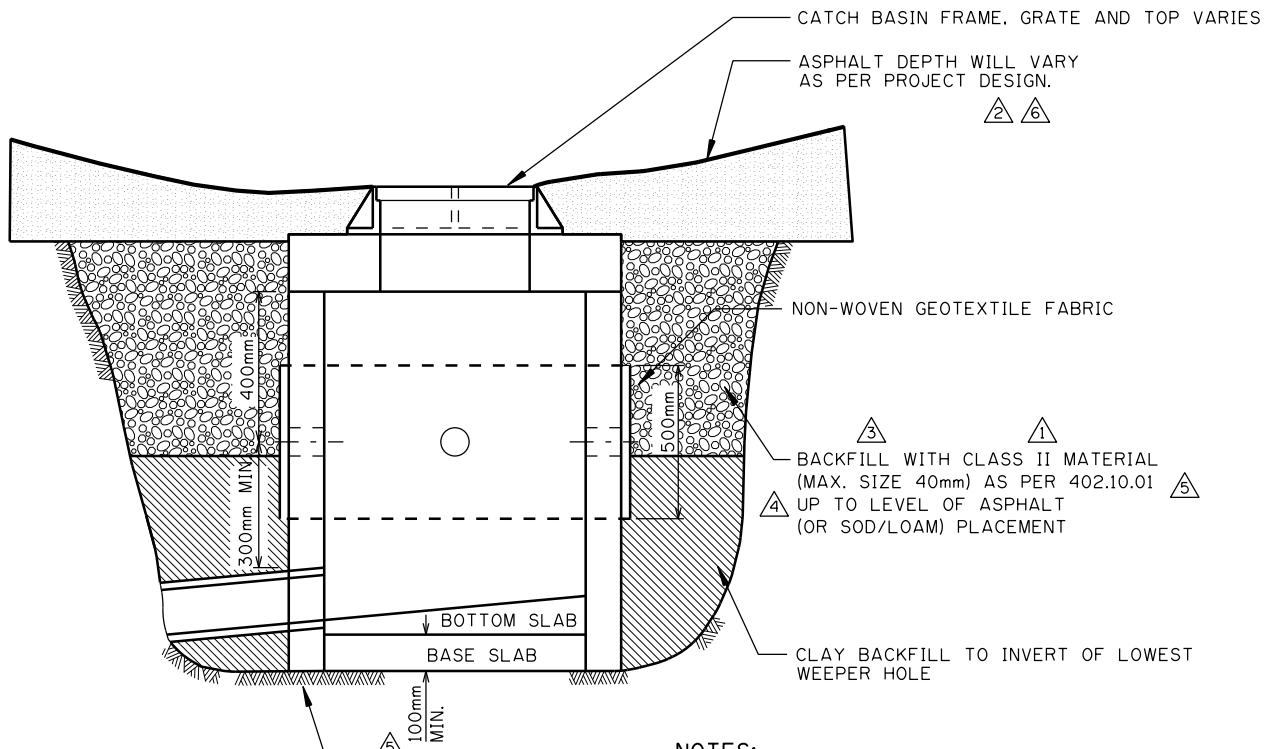

SECTION 'A-A'

△4
 MAXIMUM 150mm OF CLASS II BEDDING MATERIAL (MAX. SIZE 40mm) AS PER 402.10.01 OR SUITABLE UNDISTURBED NATIVE MATERIAL △5

NOTES:

1. BARRELS TO CONFORM TO A.S.T.M. C-478 (LATEST EDITION).
2. GEOTEXTILE SHALL BE MINIMUM 200 gm²/m
3. ALTERNATE PRECAST CATCH BASIN BASE SEE SHEET 31A.
4. OPEN GRATE CATCH BASINS IN GRAVEL LANES REQUIRE MINIMUM 2m ASPHALT APRON; OPEN GRATE CATCH BASINS IN GRASS MUNICIPAL RESERVES REQUIRE MINIMUM 2m CONCRETE APRON.

DIMENSIONS ARE IN MILLIMETRES UNLESS OTHERWISE NOTED

6	2020/02/05	ADDED NOTE	M.C.	Date	1999/09/14		SEWER CONSTRUCTION	Sheet 43A
5	2015/11/18	REVISED SPEC NUMBER & CORRECTED DIM	M.C.	Scale	N.T.S.			
4	2007/08/01	MAX SIZE REVISED TO 40mm		Approved by		STANDARD CATCH BASIN BARREL INSTALLATION DETAIL	File Number 452.1002.028	
3	2006/09/01	CHANGED FROM WASHED GRAVEL TO CLASS II MATERIAL		for The City of Calgary				
2	2003/11/10	NOTE ADDED. SHADING CHANGED						
1	2002/20/11	CLARIFIED TYPE AND LEVEL OF FILL						
No.	Date	Revision	App'd					

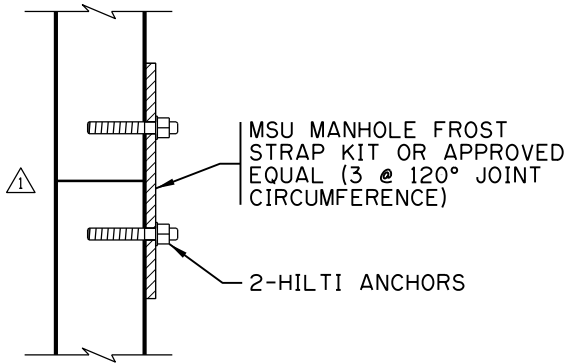

FROST STRAP KIT DETAIL

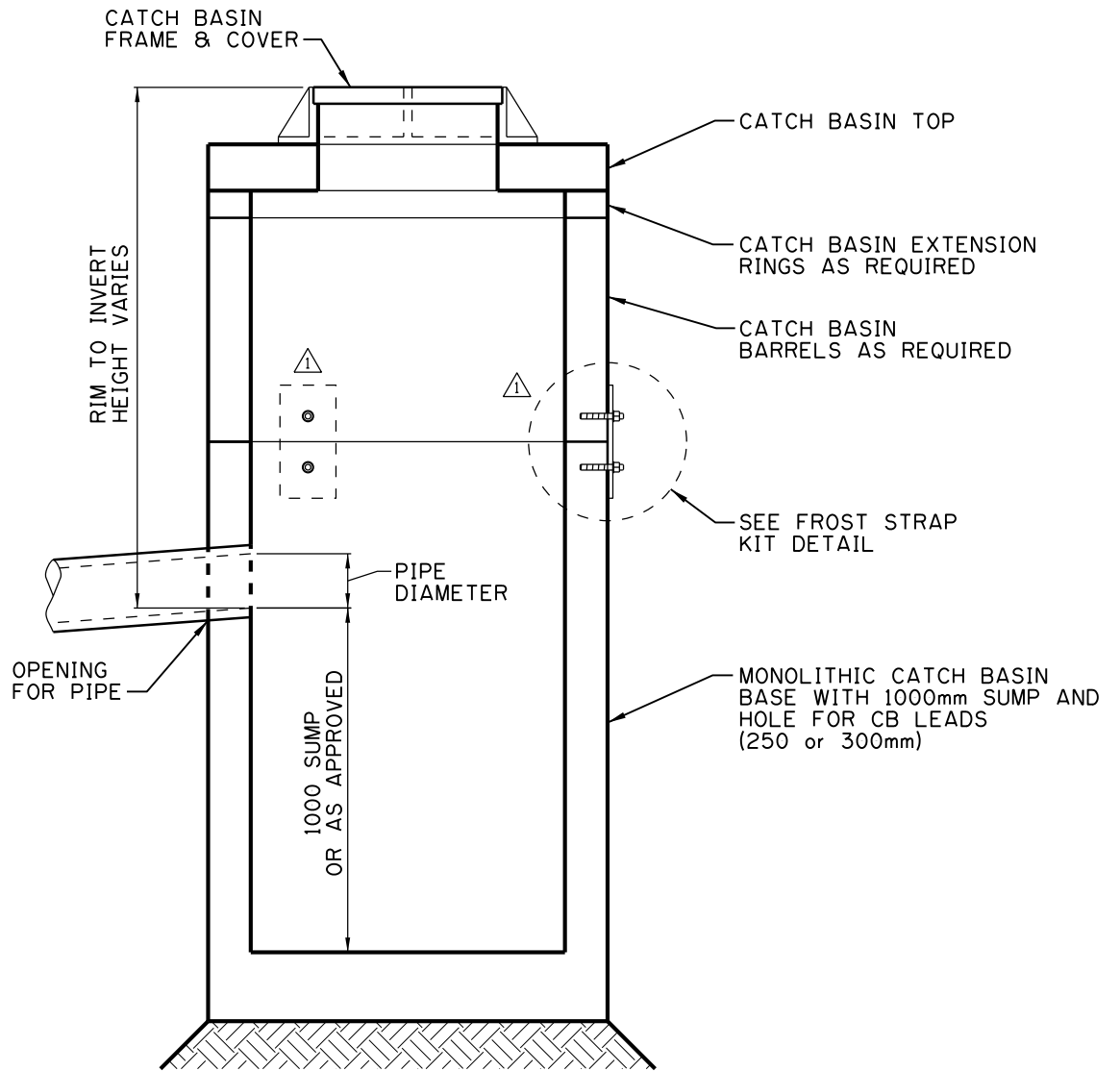

CATCH BASIN ASSEMBLY WITH 1000mm SUMP

DIMENSIONS ARE IN MILLIMETRES UNLESS OTHERWISE NOTED

No.	Date	Revision	M.C.
1	2020/02/07	REVISED TITLE & ADDED DETAIL	

Date
2013/10/29

Scale
N.T.S.

Approved by
[Signature]

for The City of Calgary

SEWER CONSTRUCTION

DOUBLE CATCH BASIN ASSEMBLY WITH SUMP

Sheet
43A-2

File Number
452.1002.029

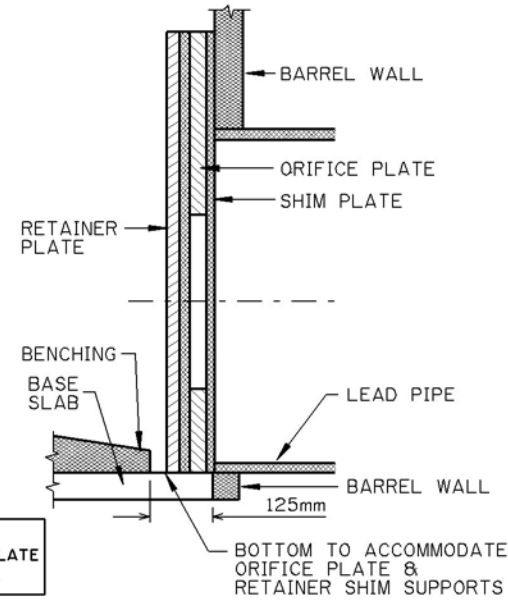
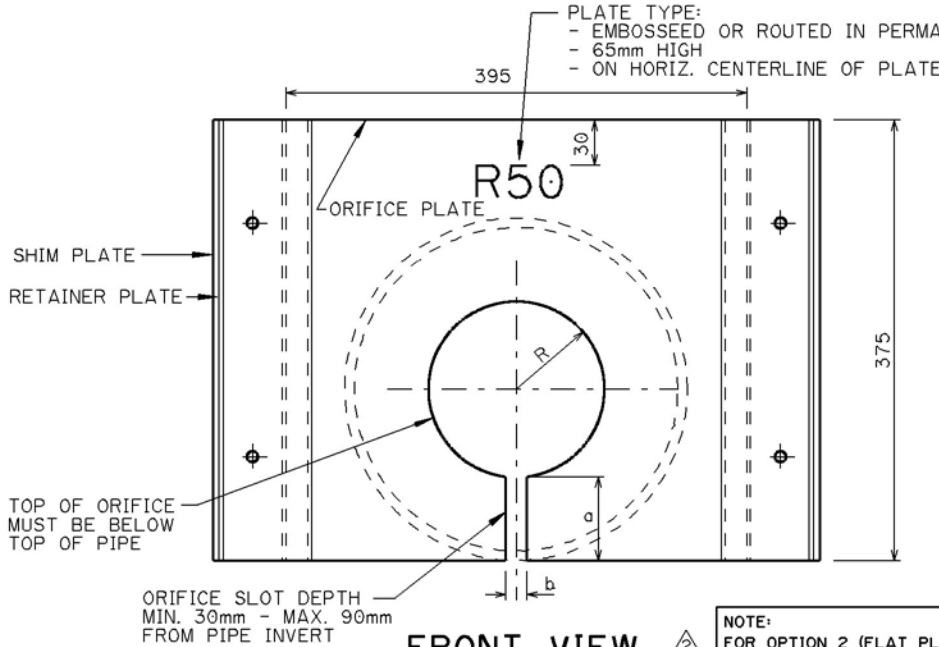
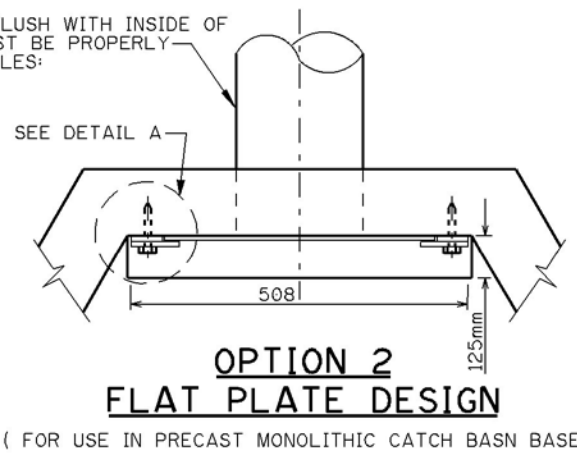
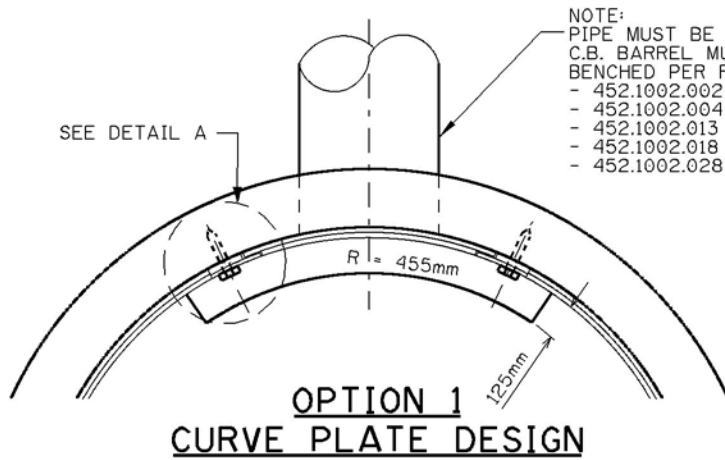

NOTE:
FOR OPTION 2 (FLAT PLATE
DESIGN) SEE SHEET 31A

SIDE VIEW OPTION 1

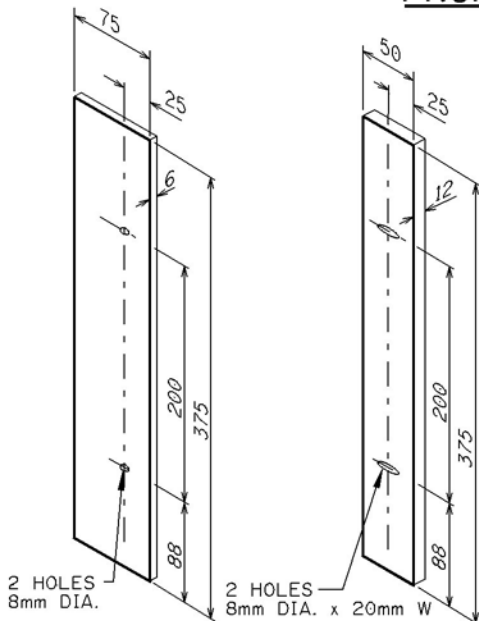

RETAINER PLATE SHIM PLATE

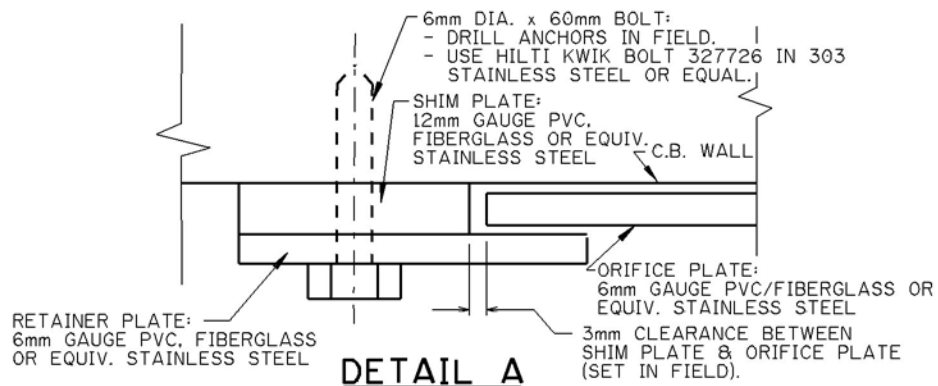

CONTROL FLOWING AT H=1.5m

TYPE	dm ³ /sec.	a	b	R
R30	20	30-90mm	30mm	30mm
R50	40	30-90mm	30mm	50mm
R70	60	30-90mm	30mm	70mm
R100	110	30-90mm*	30mm	100mm

*TOP OF ICD OPENING SHOULD
NOT BE ABOVE CROWN OF
LEAD C.B. PIPE

DIMENSIONS ARE IN MILLIMETRES
UNLESS OTHERWISE NOTED

No.	Date	Revision
2	2004/11/01	CHANGED NOTE
1	2001/09/20	GENERAL REVISION

Date
1999/09/14
Scale
N.T.S.
Approved by
[Signature]
for The City of Calgary

SEWER CONSTRUCTION
CATCH BASIN INLET CONTROL
ASSEMBLY FOR PLATE
TYPE CONTROL

Sheet
43B
File Number
452.1002.031

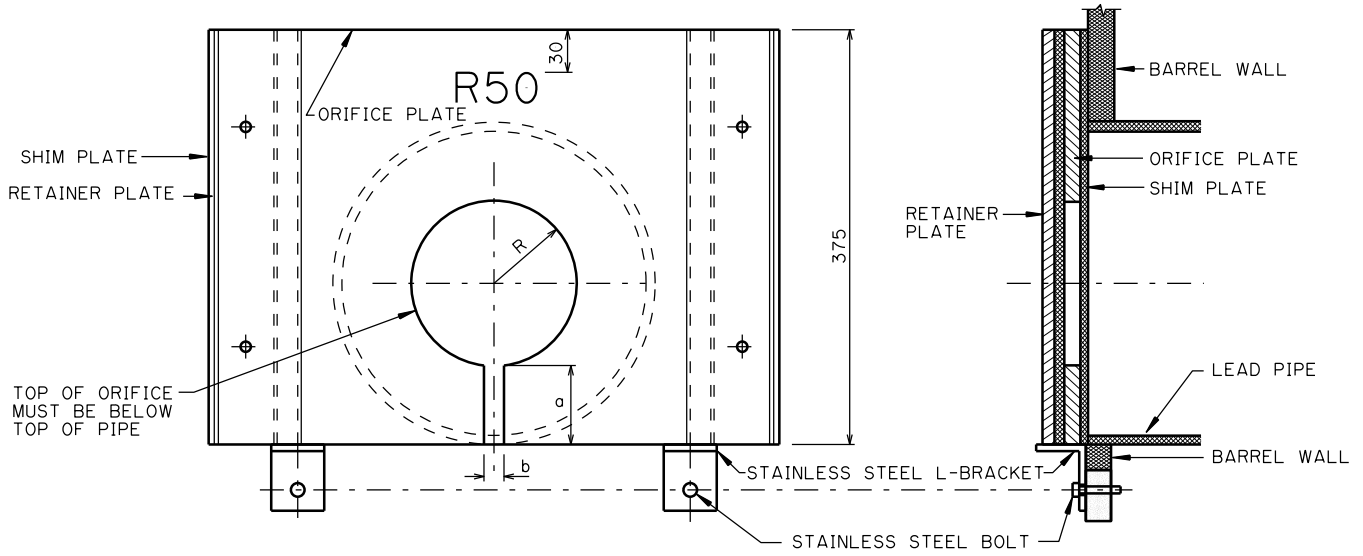

FRONT VIEW

SIDE VIEW OPTION 1

DETAIL FOR DEEP SUMP CATCH BASINS ONLY
RETAINING BRACKETS TO SUPPORT ICD PLATE

DIMENSIONS ARE IN MILLIMETRES
 UNLESS OTHERWISE NOTED

No.	Date	Revision	App'd

Date
2013/10/29

Scale
N.T.S.

Approved by
AS

for The City of Calgary

SEWER CONSTRUCTION

DEEP SUMP CATCH BASIN
 INLET CONTROL
 RETAINING BRACKETS

Sheet
43B-2

File Number
452.1002.031A

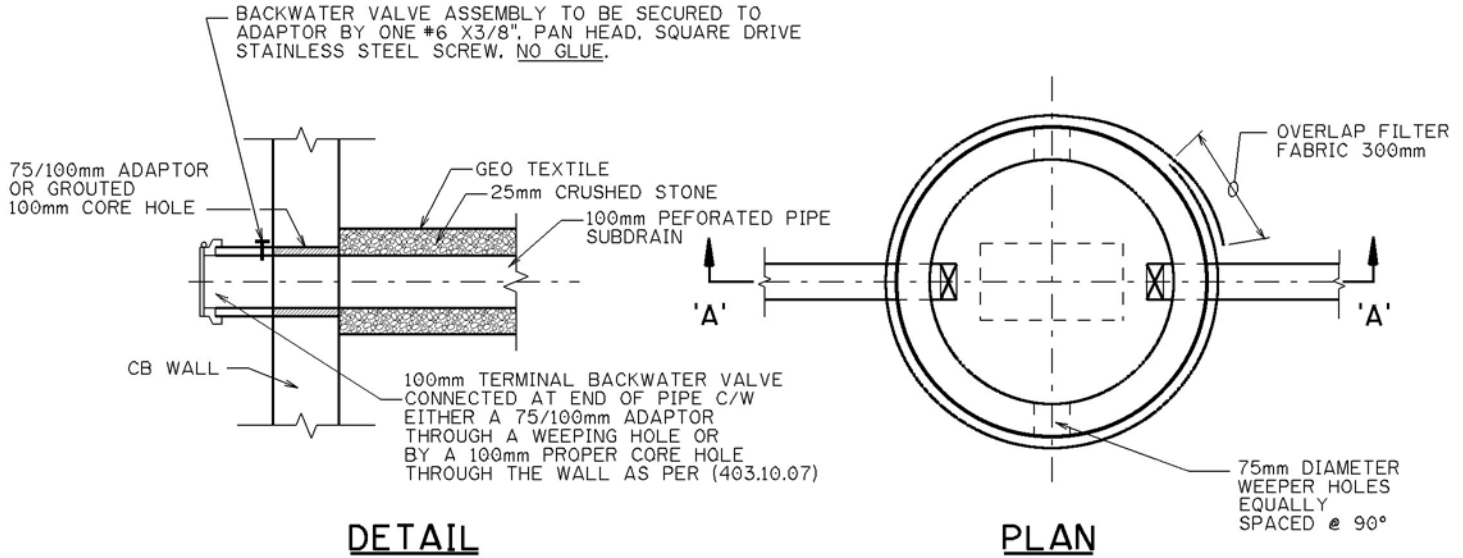

*** NOTE:**

1. A TERMINAL BACKWATER VALVE IS NOT REQUIRED IF A CATCH BASIN HAS NO INLET CONTROL DEVICE (ICD)
2. PERFORATED DRAIN PIPE ORIENTATION TO BE DETERMINED IN FIELD.
3. BACKWATER VALVE SHOULD BE INSTALLED AS CLOSE TO INSIDE WALL OF THE C.B. BARREL AS PRACTICALLY POSSIBLE AS NOT TO INTERFERE WITH C.B. ACCESS.

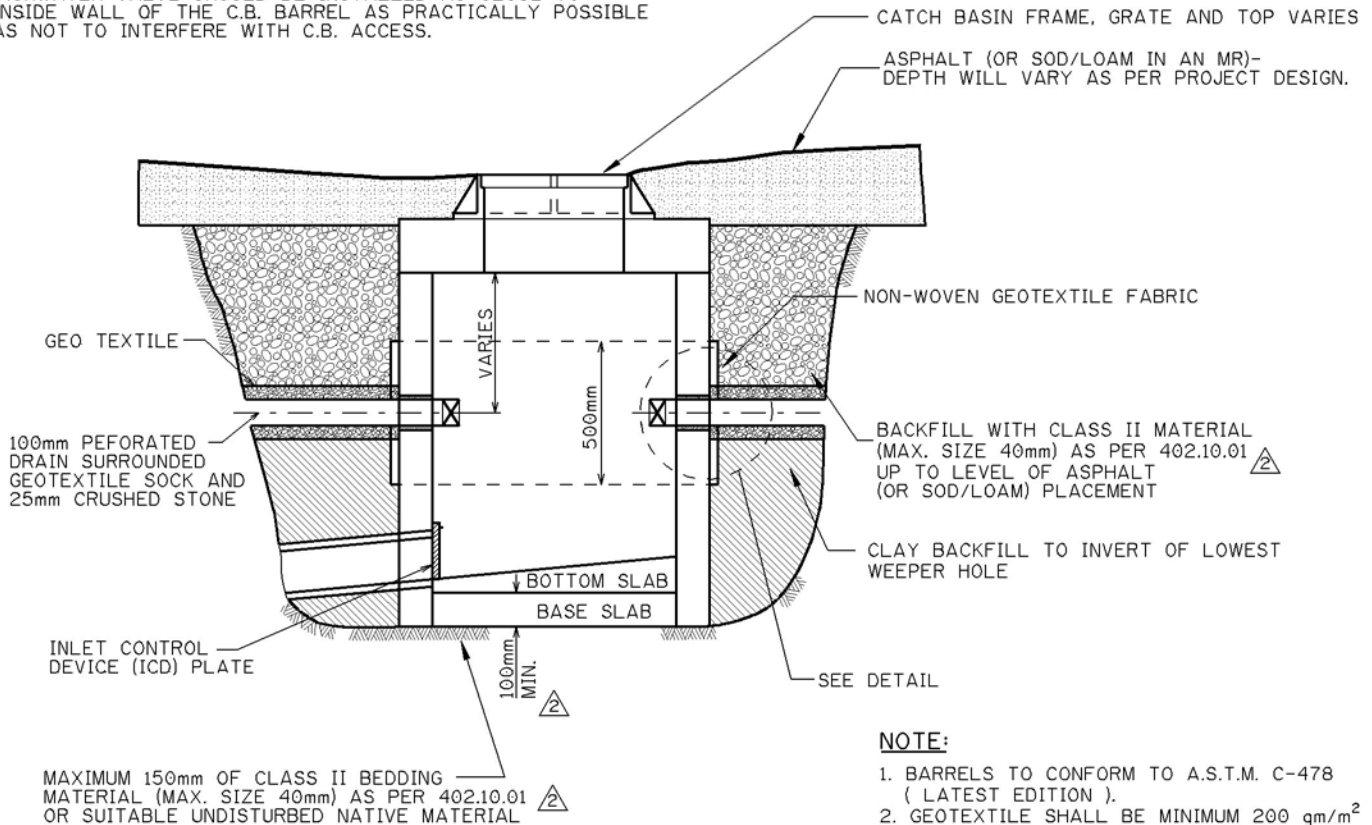

SECTION 'A-A'

DIMENSIONS ARE IN MILLIMETRES UNLESS OTHERWISE NOTED

No.	Date	Revision	App'd
2	2015/11/18	REVISED NOTES AND DIMENSION	MC
1	2008/09/16	NOTES ADDED	

Date
2007/12/03

Scale
N.T.S.

Approved by
AS

for The City of Calgary

SEWER CONSTRUCTION

STANDARD CONNECTION OF ROAD SUB-DRAIN TO CATCH BASIN BARREL

Sheet
43C

File Number
452.1002.041

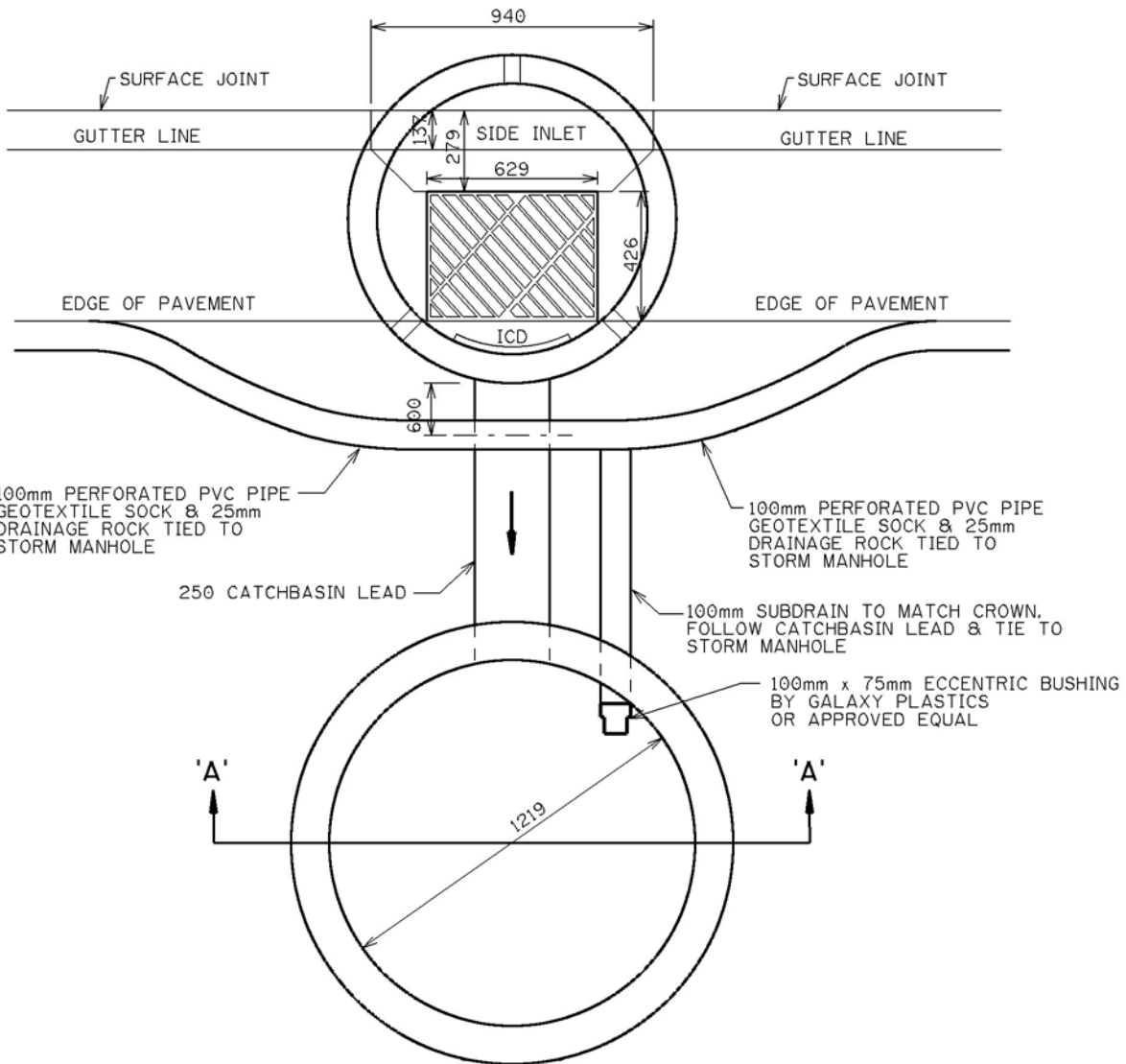

PLAN

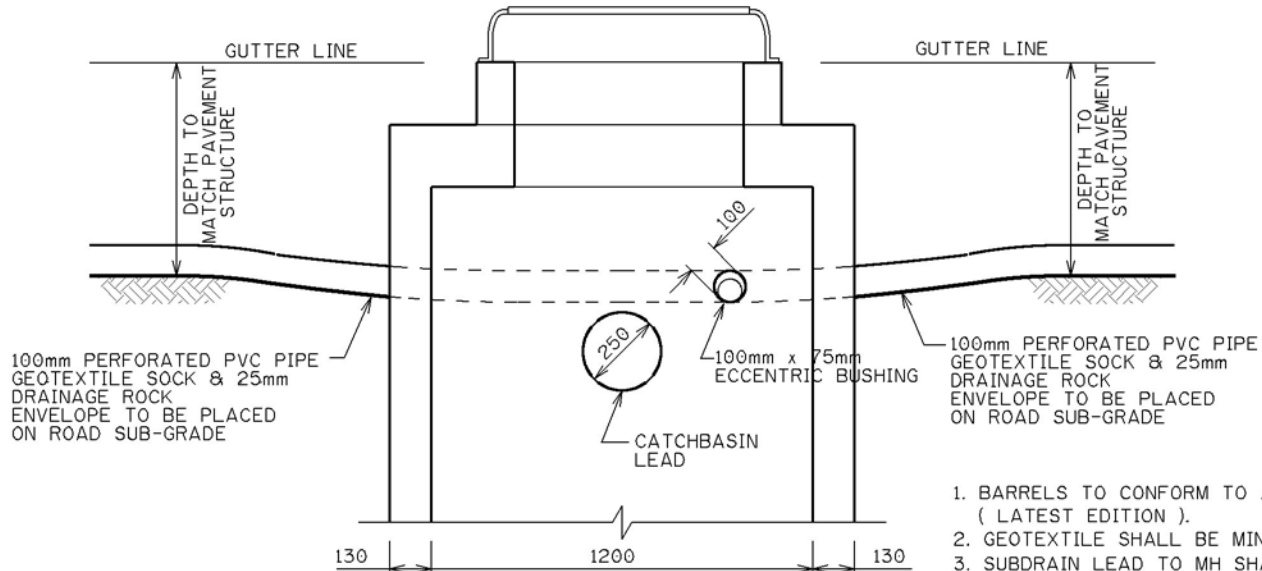

SECTION 'A-A'

1. BARRELS TO CONFORM TO A.S.T.M. C-478 (LATEST EDITION).
2. GEOTEXTILE SHALL BE MINIMUM 200 gm/m²
3. SUBDRAIN LEAD TO MH SHALL FOLLOW CB LEAD + MATCH GRADE

DIMENSIONS ARE IN MILLIMETRES UNLESS OTHERWISE NOTED

No.	Date	Revision	App'd
1	2008/09/16	NOTES ADDED	

Date
2003/09/03
Scale
N.T.S.
Approved by
J.M. Miller
for The City of Calgary

SEWER CONSTRUCTION

STANDARD CONNECTION
OF ROAD SUB-DRAIN TO
STORM MANHOLE BARREL

Sheet
43D
File Number
452.1002.042

SEE STANDARD DWG. SHEET #21
(452.1002.008)
FOR SIDE INLET DESIGN

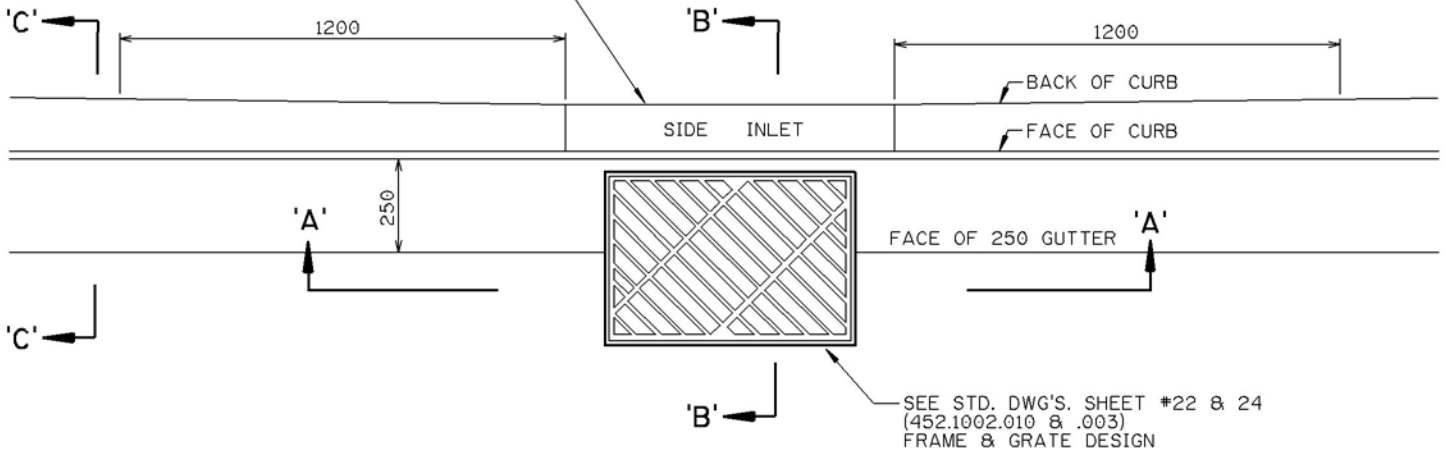

PLAN

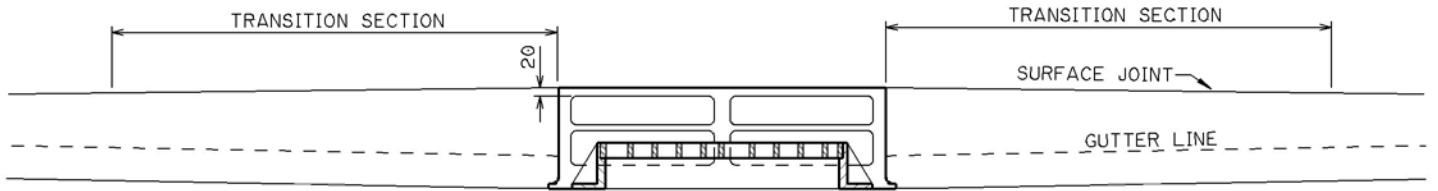

SECTION 'A-A'

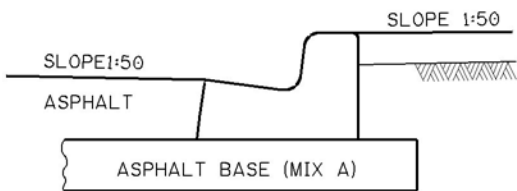

SECTION 'C-C'

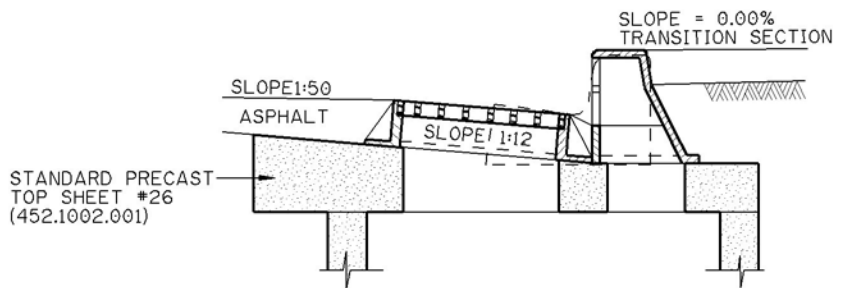

SECTION 'B-B'

DIMENSIONS ARE IN MILLIMETRES
UNLESS OTHERWISE NOTED

No.	Date	Revision	App'd

Date
1999/09/14

Scale
N.T.S.

Approved by
[Signature]

For The City of Calgary

SEWER CONSTRUCTION

TYPE 'C' CATCH BASIN
IN 250 GUTTER

Sheet
44

File Number
452.1002.005

SEE STANDARD DWG. SHEET #21
(452.1002.008)
FOR SIDE INLET DESIGN

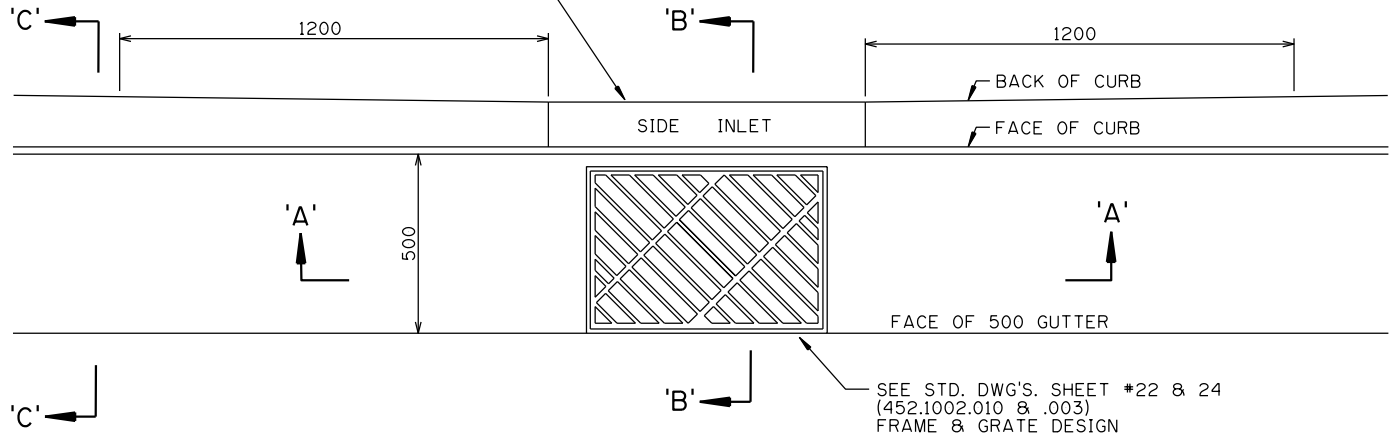

PLAN

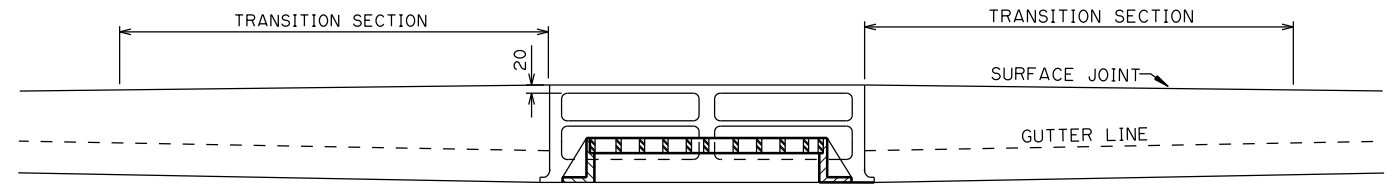

SECTION 'A-A'



SECTION 'C-C'

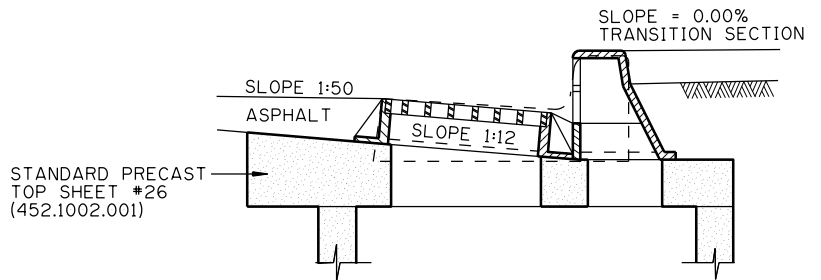

SECTION 'B-B'

DIMENSIONS ARE IN MILLIMETRES
UNLESS OTHERWISE NOTED

No.	Date	Revision	App'd

Date
1999/09/14

Scale
N.T.S.

Approved by
[Signature]

for The City of Calgary

SEWER CONSTRUCTION

**TYPE 'C' CATCH BASIN
IN 500 GUTTER**

Sheet
45

File Number
452.1002.006

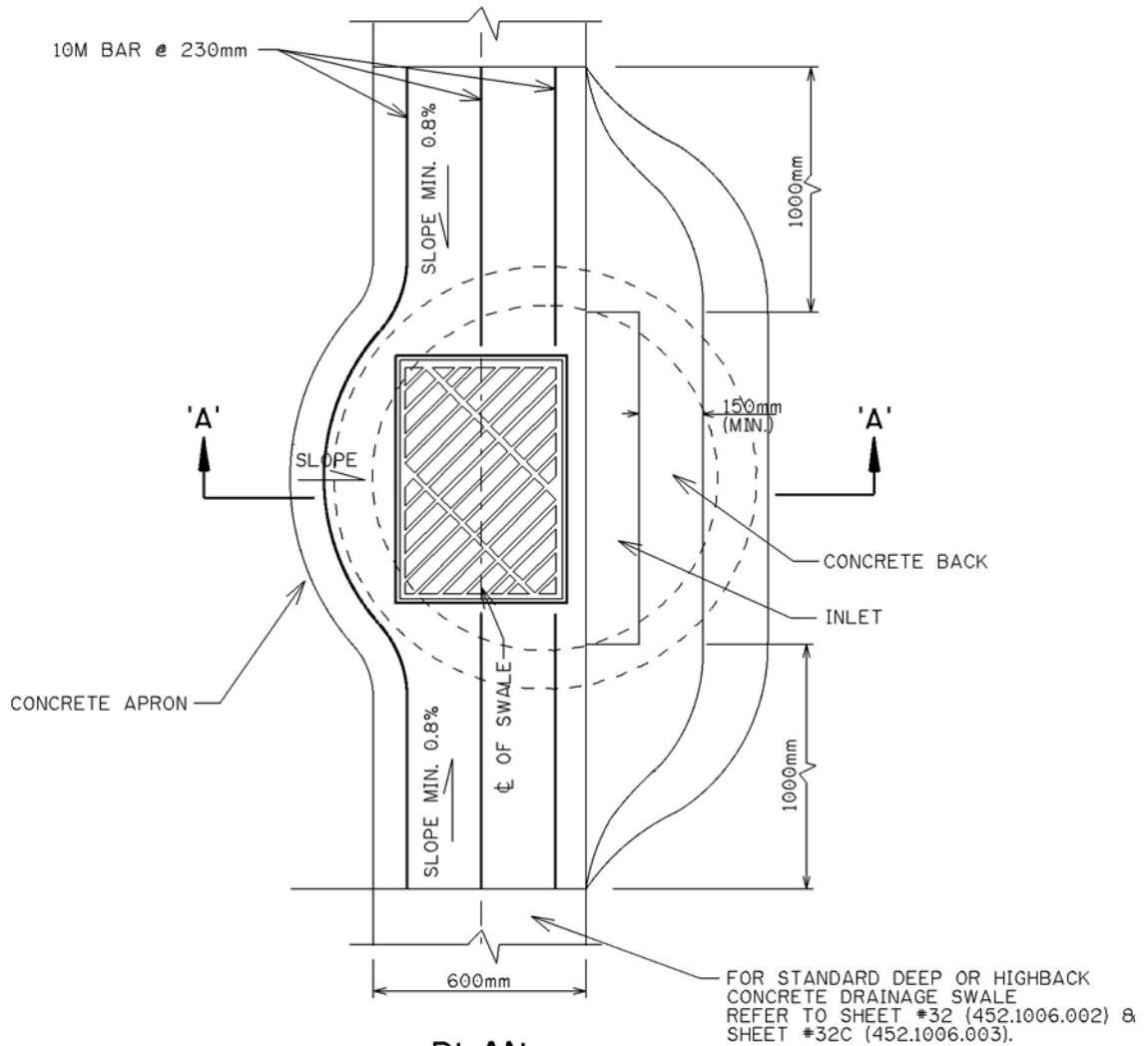

PLAN

FOR STANDARD DEEP OR HIGHBACK CONCRETE DRAINAGE SWALE REFER TO SHEET #32 (452.1006.002) & SHEET #32C (452.1006.003).

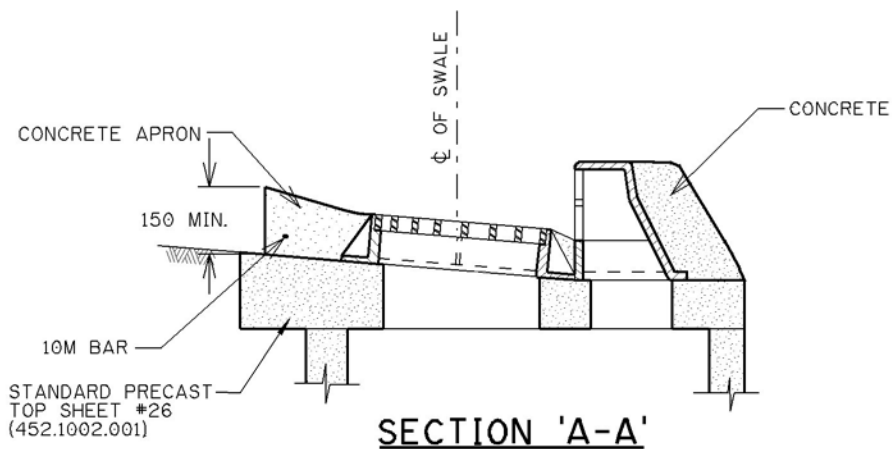

SECTION 'A-A'

NOTE:

- LEAVE A 3000mm GAP IN THE CONCRETE SWALE.
- MATCH GRADES AT THE SWALE ENDS AND SLOPE DOWN TO MATCH GRADES AT THE CB GRATE.
- ENSURE ADEQUATE EASEMENT WIDTH FOR THE CB AND CB LEAD.
- STORM BACK IS NOT REQUIRED IF CB IS AN INTERCEPTOR BEFORE CROSSING A MONO SIDEWALK.

DIMENSIONS ARE IN MILLIMETRES UNLESS OTHERWISE NOTED

No.	Date	Revision	App'd
1	2003/11/10	CHANGED GUTTER TO SWALE	

Date
2002/09/24
Scale
N.T.S.
Approved by
[Signature]
for The City of Calgary

SEWER CONSTRUCTION
STANDARD TYPE 'C'
CATCH BASIN IN A
CONCRETE DRAINAGE SWALE

Sheet
45A
File Number
452.1002.038

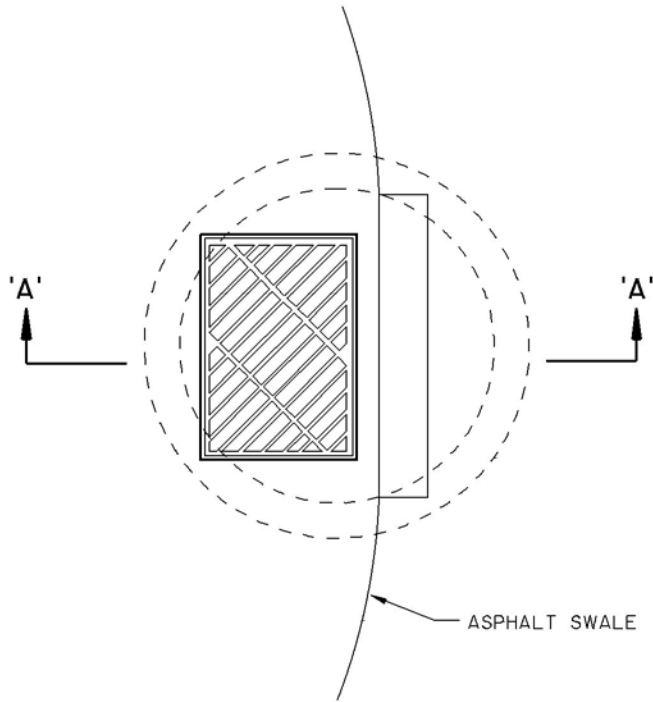

PLAN

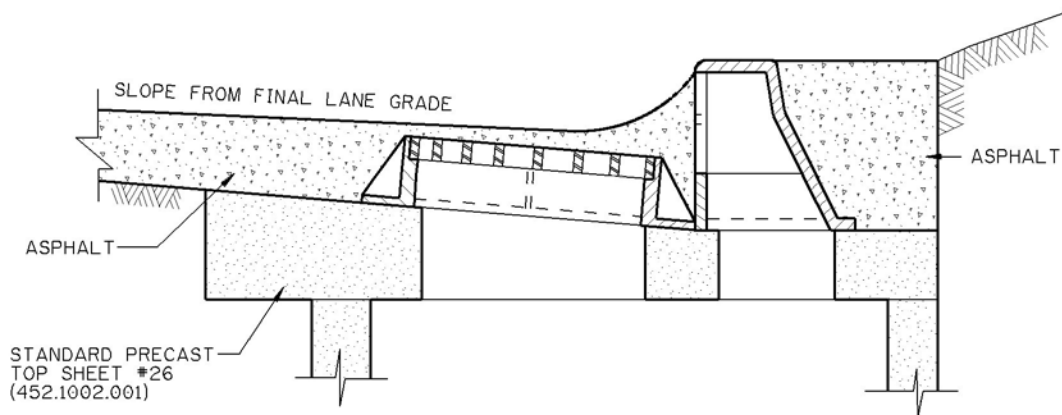

SECTION 'A-A'

NOTE:
 -LOCATION TO SUIT FIELD CONDITIONS
 -IN LANES - LOCATE TO AVOID GAS MAINS
 AND TRAVELLED PORTIONS

DIMENSIONS ARE IN MILLIMETRES
 UNLESS OTHERWISE NOTED

No.	Date	Revision	App'd

Date
 1999/09/14
 Scale
 N.T.S.
 Approved by

 for The City of Calgary

SEWER CONSTRUCTION

**STANDARD TYPE 'C'
 LANE CATCH BASIN**

Sheet
46
 File Number
 452.1002.009

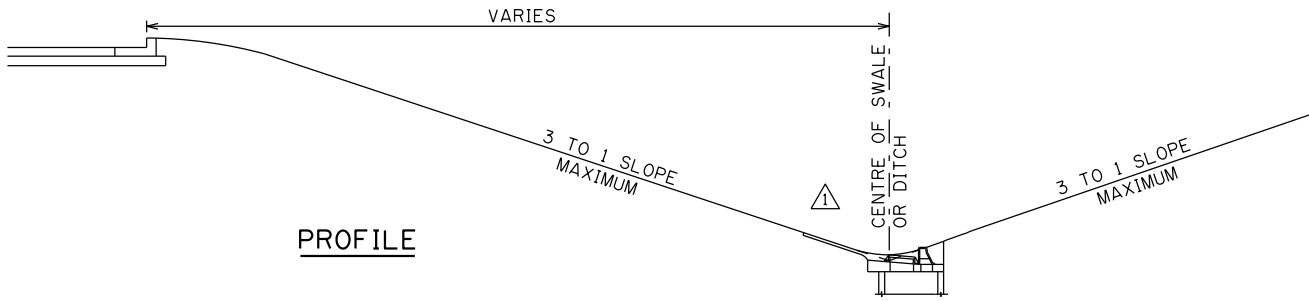

PROFILE

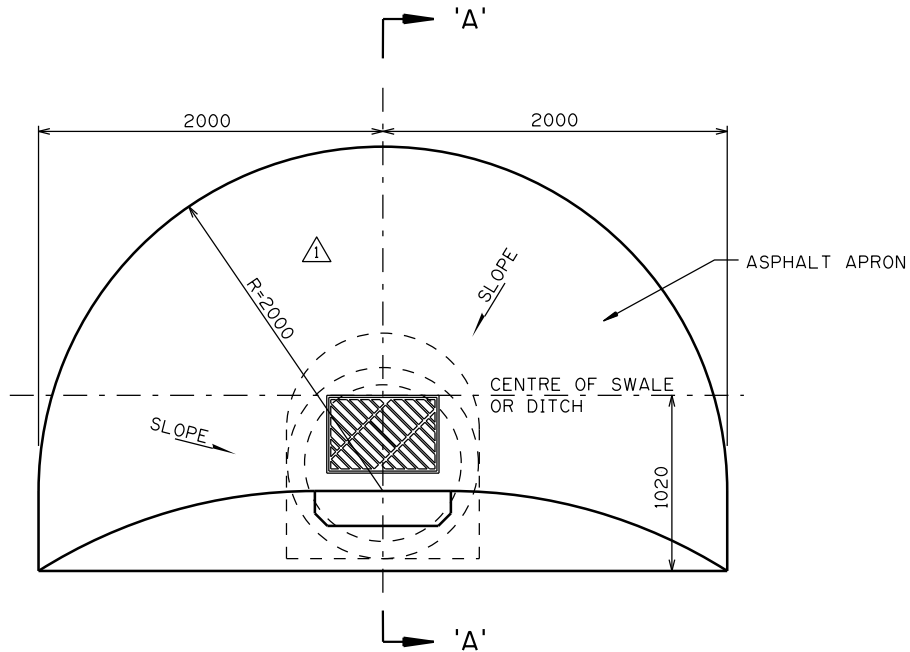

PLAN

NOTE:

-IF THE DIRECTION OF DRAINAGE IS PAST THE CATCH BASIN: i.e. THE CATCH BASINS ARE NOT LOCATED IN A DITCH LOW, THEN THE DOWNSTREAM SIDE OF THE ASPHALT APRON IS TO BE RAISED TO THE LEVEL OF THE TOP OF THE CATCH BASIN STORM BACK, THUS CREATING A DAM IN THE DITCH APPROX. 150mm HIGH.

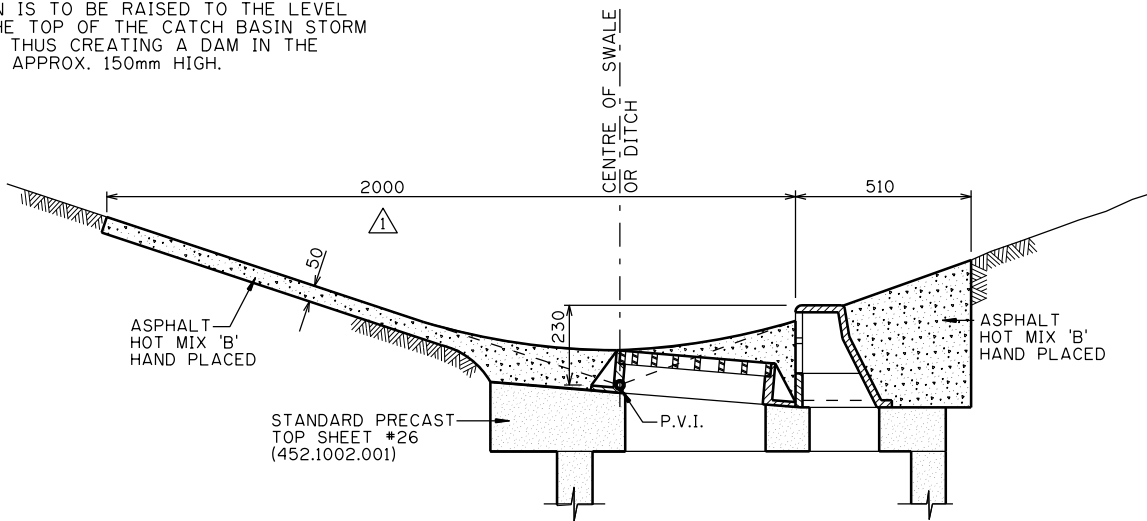

SECTION 'A-A'

DIMENSIONS ARE IN MILLIMETRES UNLESS OTHERWISE NOTED

No.	Date	Revision
1	2020/06/02	REVISED DETAIL AND DIMENSIONS

Date
1999/09/14

Scale
N.T.S.

Approved by
[Signature]

for The City of Calgary

SEWER CONSTRUCTION

STANDARD TYPE 'C'
CATCH BASIN IN HIGHWAY
SWALES OR DITCHES

Sheet
47

File Number
452.1002.012

SEE STANDARD DWG. SHEET #21
(452.1002.008)
FOR SIDE INLET DESIGN

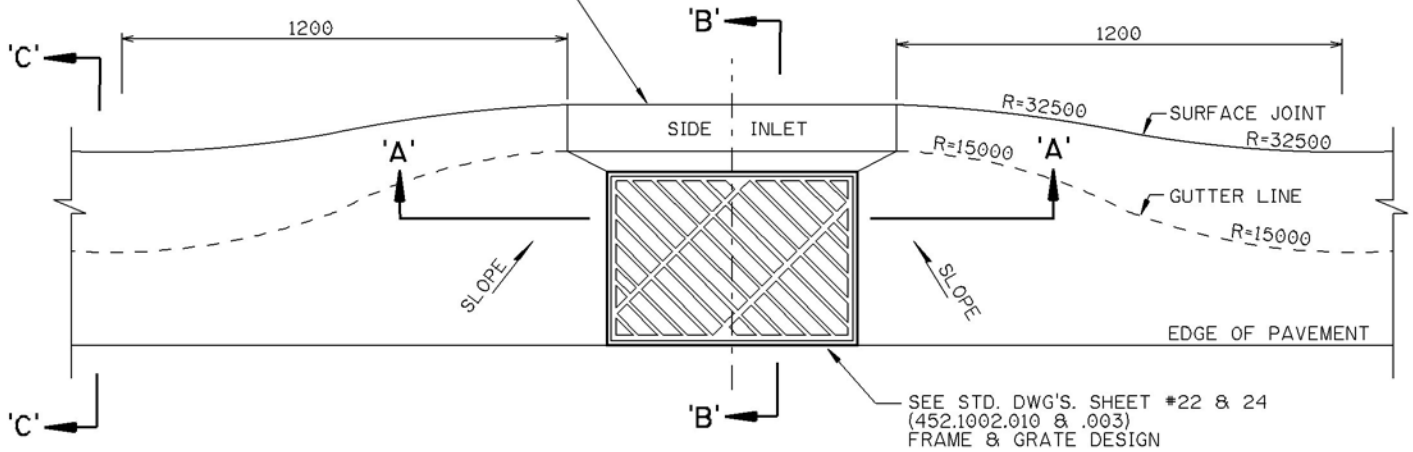

PLAN

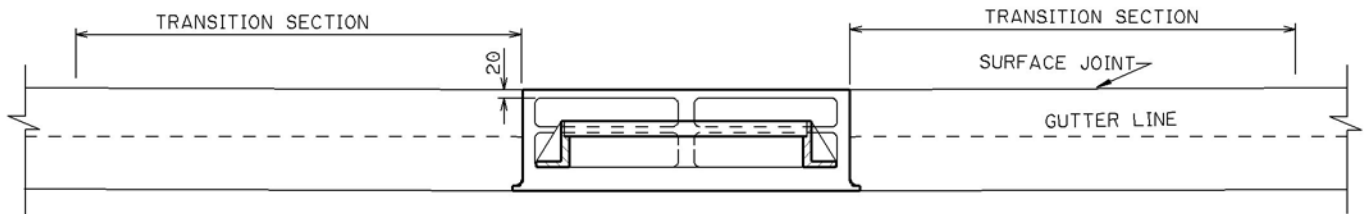

SECTION 'A-A'

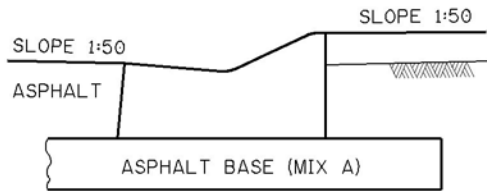

SECTION 'C-C'

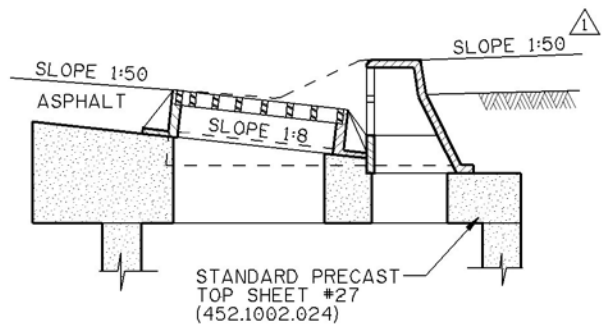

SECTION 'B-B'

DIMENSIONS ARE IN MILLIMETRES
UNLESS OTHERWISE NOTED

No.	Date	Revision	App'd
1	2001/10/01	REVISED SLOPE	

Date
1999/09/14
Scale
N.T.S.
Approved by
[Signature]
for The City of Calgary

SEWER CONSTRUCTION
**TYPE 'C' CATCH BASIN
IN LOW PROFILE ROLLED
CURB WITH 250 GUTTER**

Sheet
48
File Number
452.1002.022

SEE STANDARD DWG. SHEET #21
(452.1002.008)
FOR SIDE INLET DESIGN

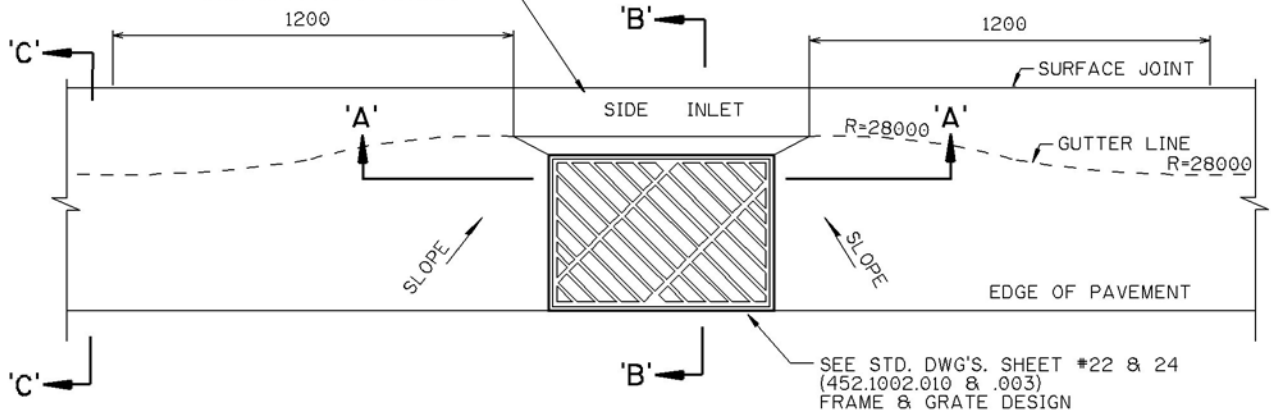

PLAN

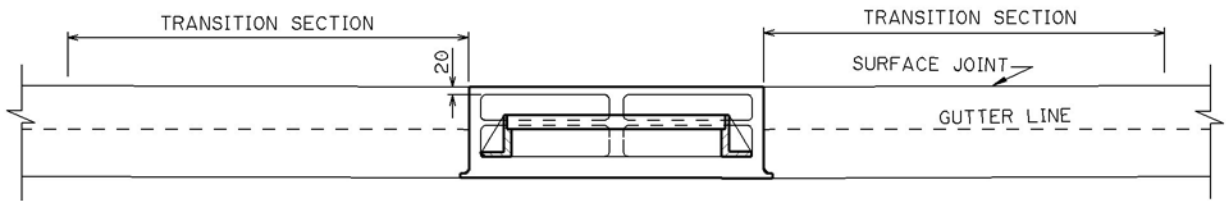

SECTION 'A-A'

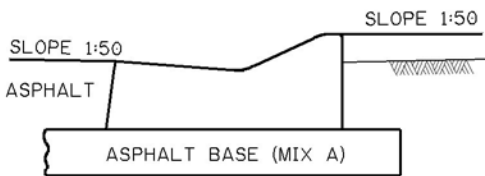

SECTION 'C-C'

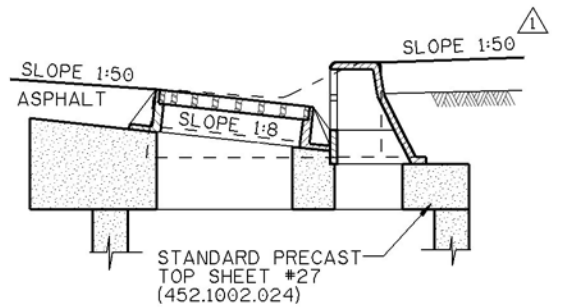

SECTION 'B-B'

DIMENSIONS ARE IN MILLIMETRES
UNLESS OTHERWISE NOTED

No.	Date	Revision	App'd
1	2001/10/01	REVISED SLOPE	

Date
1999/09/14

Scale
N.T.S.

Approved by
[Signature]

For The City of Calgary

SEWER CONSTRUCTION

TYPE 'C' CATCH BASIN
IN LOW PROFILE ROLLED
CURB WITH 500 GUTTER

Sheet
49

File Number
452.1002.026

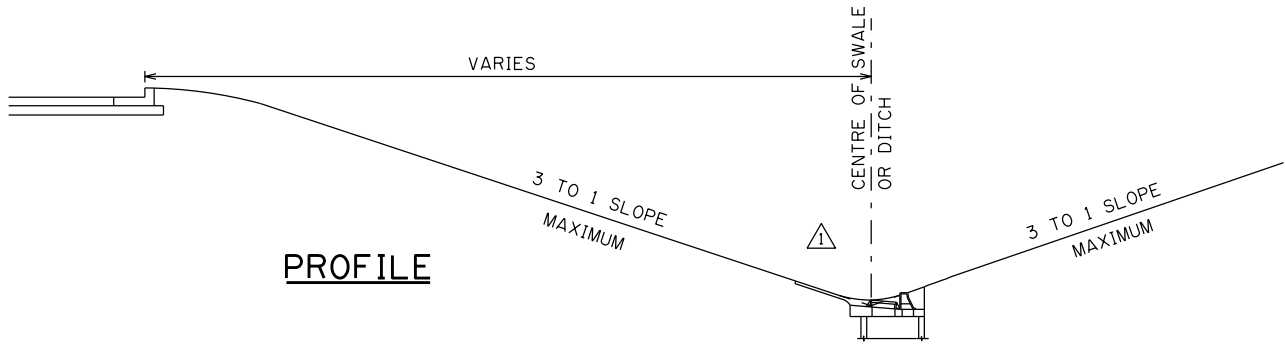

PROFILE

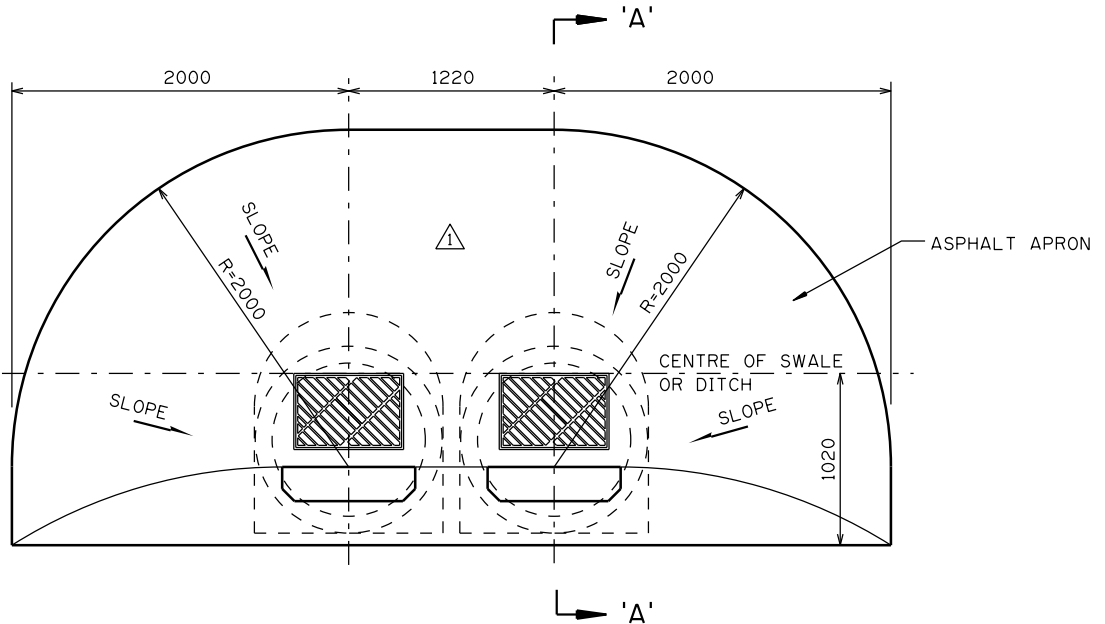

PLAN

NOTE:

IF THE DIRECTION OF DRAINAGE IS PAST THE CATCH BASIN; i.e. THE CATCH BASINS ARE NOT LOCATED IN A DITCH LOW, THEN THE DOWNSTREAM SIDE OF THE ASPHALT APRON IS TO BE RAISED TO THE LEVEL OF THE TOP OF THE CATCH BASIN STORM BACK, THUS CREATING A DAM IN THE DITCH APPROX. 150mm HIGH.

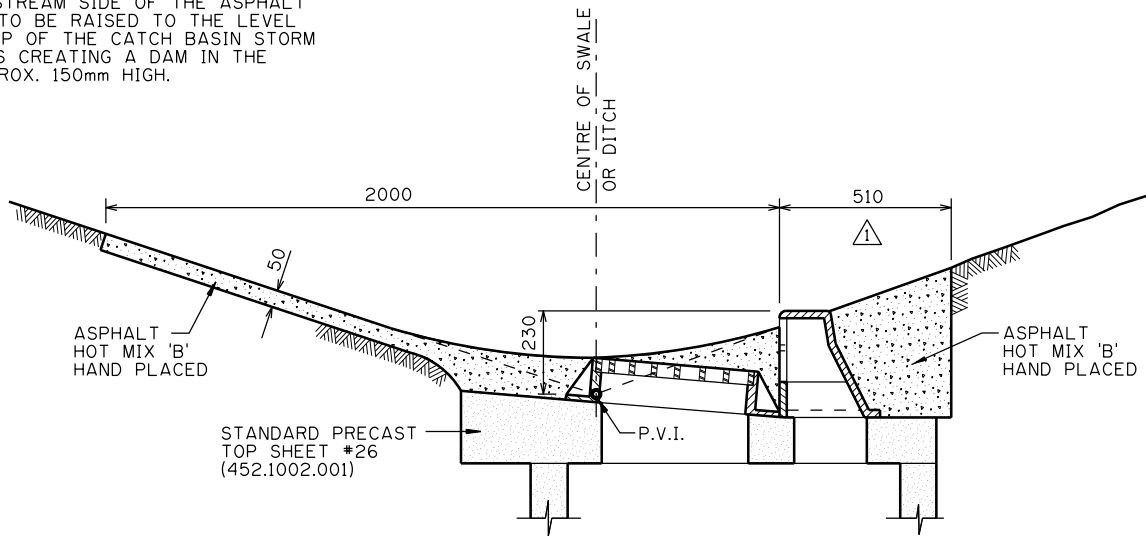

SECTION 'A-A'

DIMENSIONS ARE IN MILLIMETRES UNLESS OTHERWISE NOTED

No.	Date	Revision
1	2020/06/04	REVISED DETAILS AND DIMENSIONS

Date
1999/09/14
Scale
N.T.S.
Approved by
[Signature]
App'd for The City of Calgary

SEWER CONSTRUCTION
STANDARD TYPE 'C' TWIN
CATCH BASIN IN HIGHWAY
SWALES OR DITCHES

Sheet
50
File Number
452.1002.011

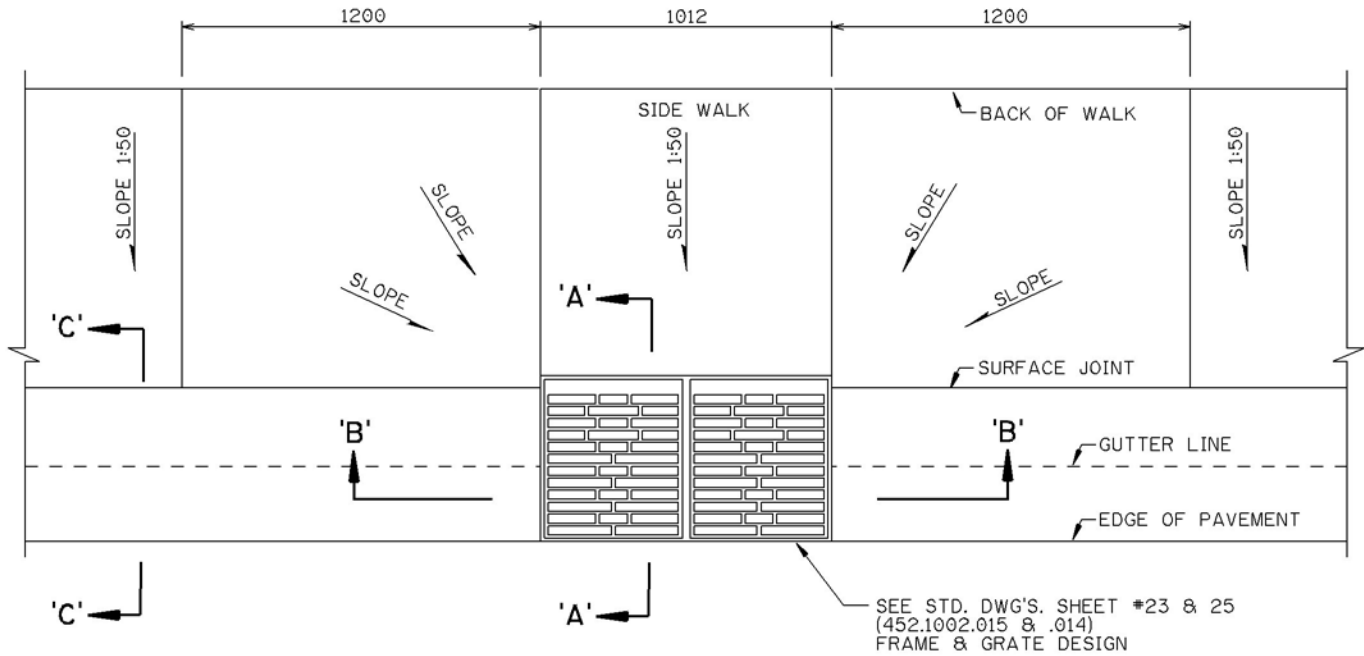

PLAN

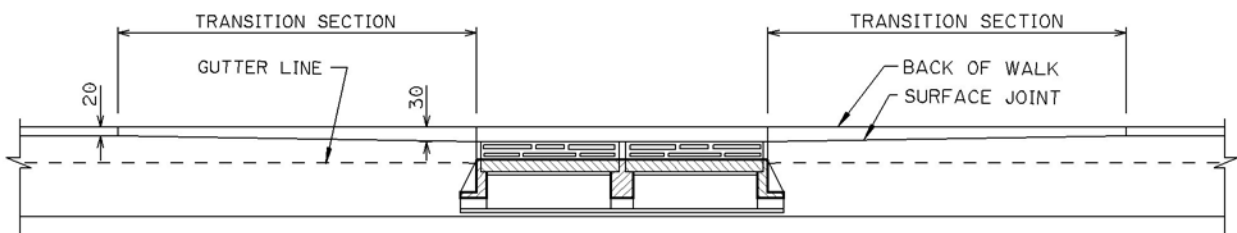

SECTION 'B-B'

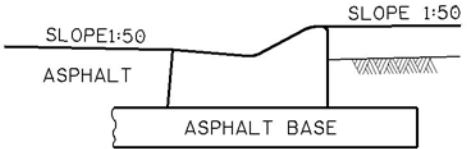

SECTION 'C-C'

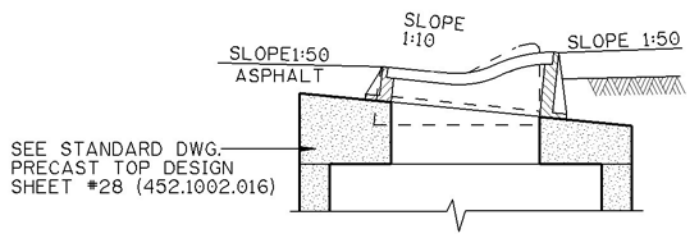

SECTION 'A-A'

DIMENSIONS ARE IN MILLIMETRES UNLESS OTHERWISE NOTED

No.	Date	Revision	App'd
1	2001/09/20	REVISED SLOPE	

Date
1999/09/14
Scale
N.T.S.
Approved by
[Signature]
for The City of Calgary

SEWER CONSTRUCTION
TYPE 'K-2' CATCH BASIN
IN LOW PROFILE ROLLED
CURB WITH 250 GUTTER

Sheet
51
File Number
452.1002.023

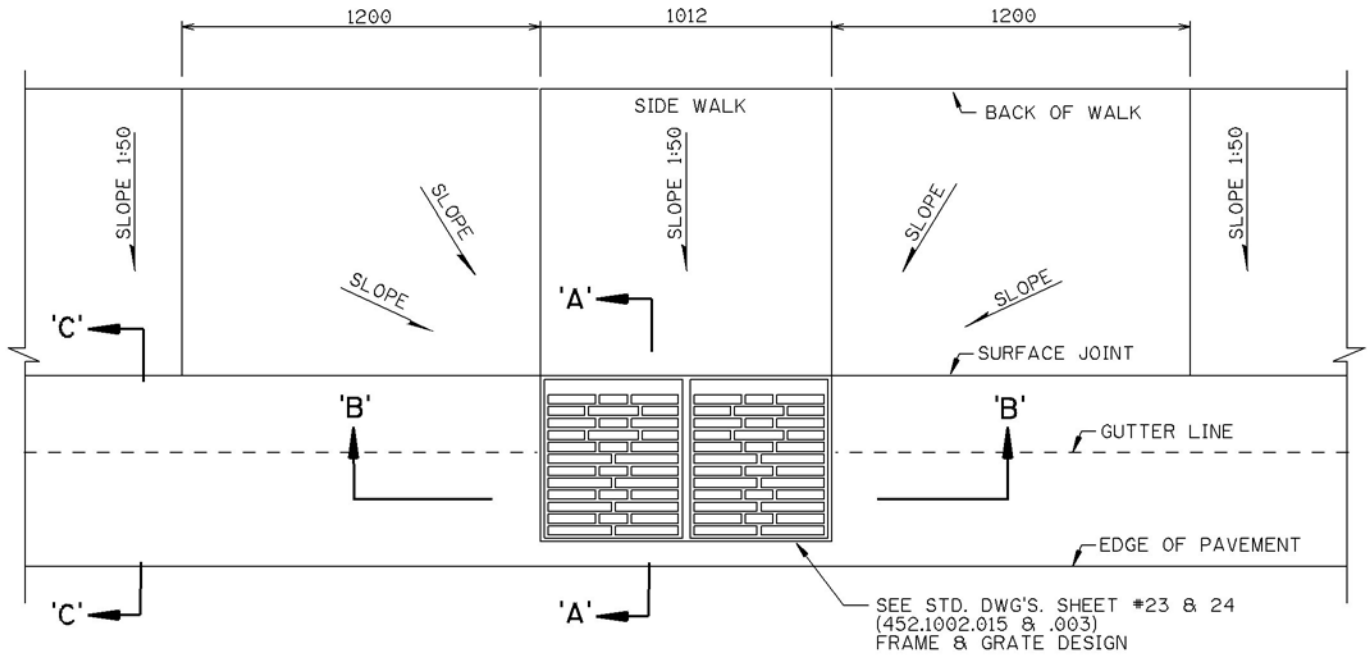

PLAN

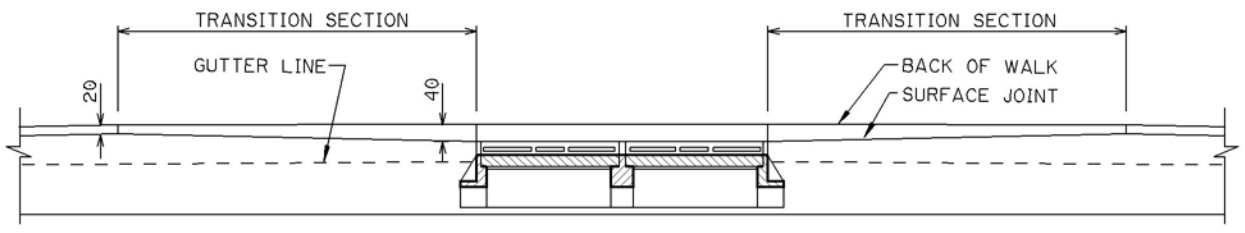

SECTION 'B-B'

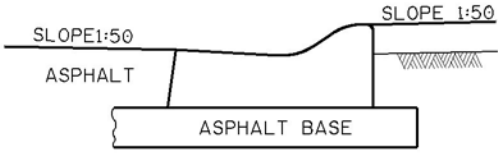

SECTION 'C-C'

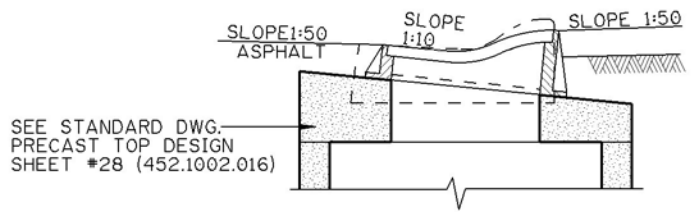

SECTION 'A-A'

SEE STANDARD DWG. PRECAST TOP DESIGN SHEET #28 (452.1002.016)

DIMENSIONS ARE IN MILLIMETRES UNLESS OTHERWISE NOTED

No.	Date	Revision	App'd
1	2001/09/20	REVISED SLOPE	

Date
1999/09/14
Scale
N.T.S.
Approved by
[Signature]
for The City of Calgary

SEWER CONSTRUCTION
TYPE 'K-2' CATCH BASIN
IN LOW PROFILE ROLLED
CURB WITH 500 GUTTER

Sheet
52
File Number
452.1002.025

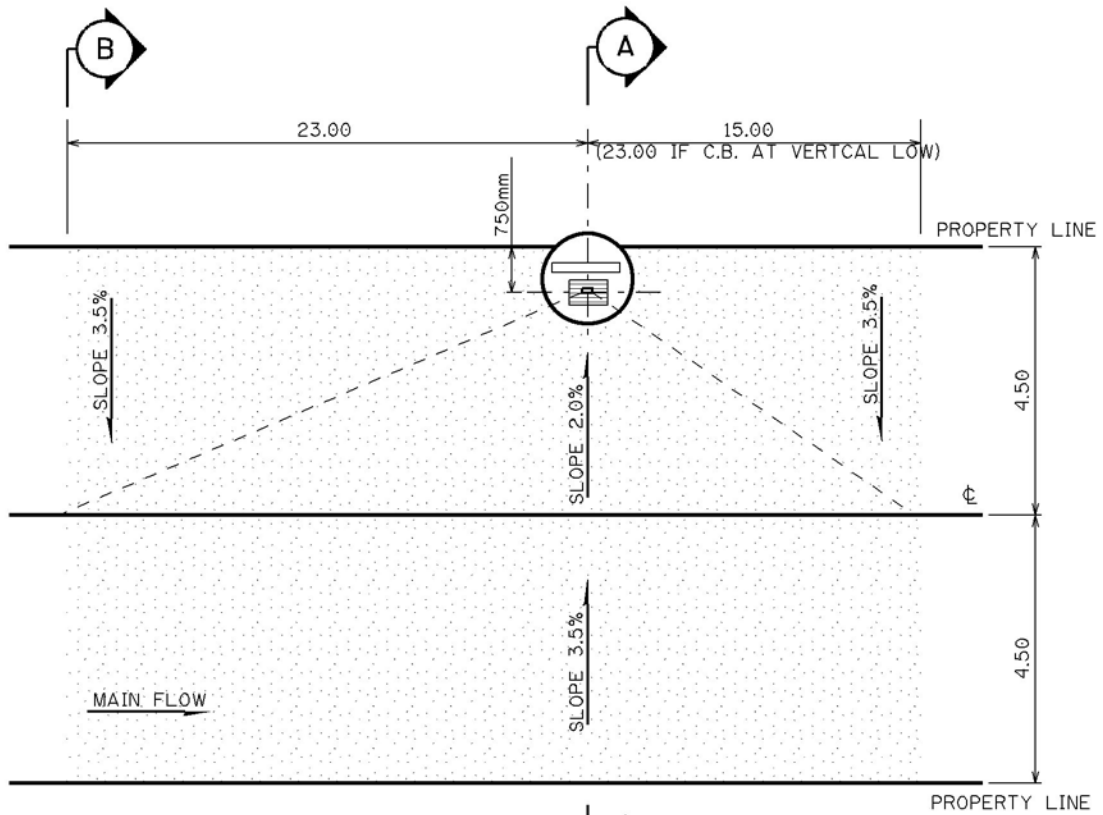

PLAN

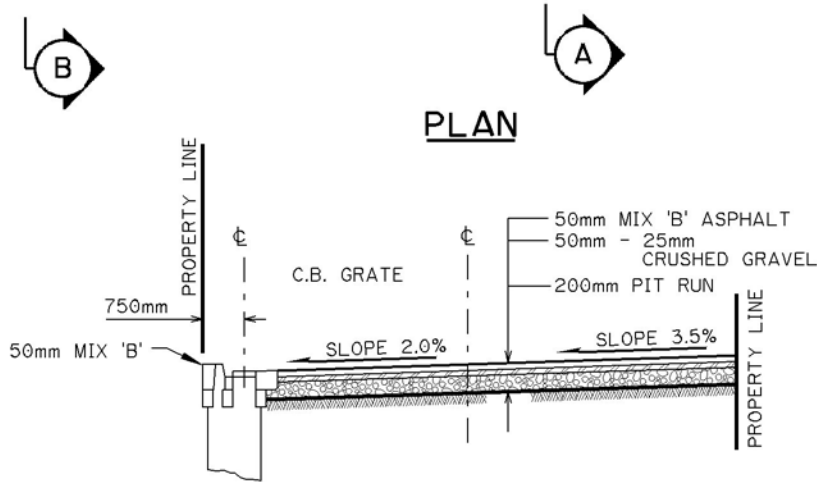

SECTION A-A

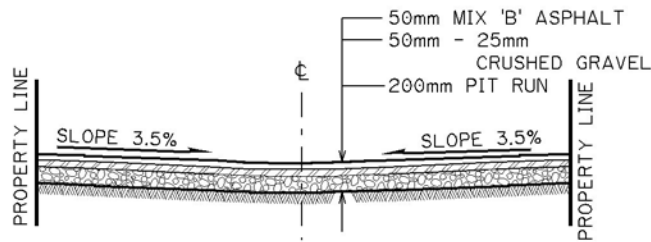

SECTION B-B

DIMENSIONS ARE IN METRES
UNLESS OTHERWISE NOTED

Sheet
53
File Number
452.1002.021

Date
1999/09/14
Scale
N.T.S.



Approved by
[Signature]
for The City of Calgary

SEWER CONSTRUCTION

TYPICAL CATCH BASIN
INSTALLATION
IN 9.00m DISHED LANE

No.	Date	Revision	App'd

CATCH BASIN FRAME & GRATE
SEE STD. DWG. SHEET #22 & 24
(452.1002.010 & .003)

FINISHED LEVEL
OF PAVEMENT

STANDARD PRECAST TOP
SEE STD. DWG.
#452.1002.020-SHEET #29

910 I.D. TYPE 'A'
PRECAST BARREL

PROPERTY LINE

CAP FOR
FUTURE

ASPHALTIC FELT

INSTALL TO R

75mm - 150mm DIA.
ROCK FILL IN DRYWELL

460

1830

1830

NOTE:

THE DRYWELL IS A TEMPORARY SYSTEM TO BE USED ONLY WHEN PUBLIC STORM SEWERS ARE NOT AVAILABLE OR AT THE DISCRETION OF THE SEWER DESIGN ENGINEER.

TO CONVERT TO CATCH BASIN (AFTER DRYWELL IS HOOKED INTO MAIN:

1. FILL WITH GRAVEL TO 100mm BELOW OUTGOING PIPE.

2. FILL ABOVE GRAVEL WITH 100mm OF 30 MPa CONCRETE.

SECTION

DIMENSIONS ARE IN MILLIMETRES
UNLESS OTHERWISE NOTED

No.	Date	Revision
2	2009/11/01	CHANGE ROCK FILL DIA. FROM 100mm TO 75mm-150mm
1	2004/11/01	CHANGE CONCRETE STRENGTH

Date
1999/09/14
Scale
N.T.S.
Approved by
AS
for The City of Calgary

SEWER CONSTRUCTION
STORM 'K-3' CATCH BASIN
AND DRYWELL DETAIL
FOR PRIVATE USE

Sheet
53A
File Number
452.1002.019

VIEW OF OPEN TRENCH AND BACKFILL MATERIAL

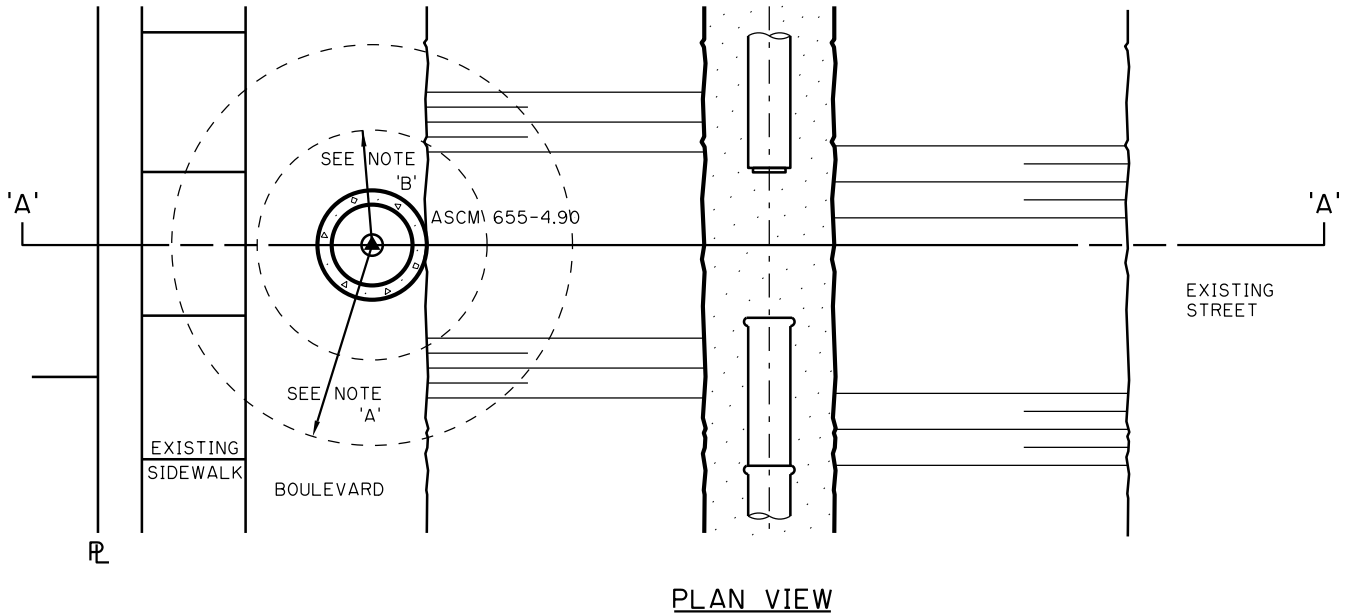

PLAN VIEW

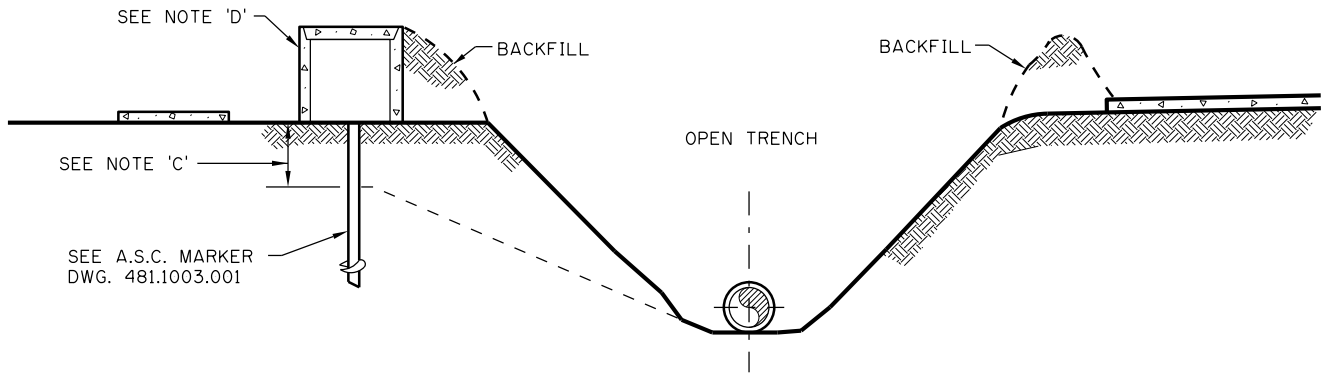

SECTION 'A-A'

NOTES:

- ⚠ A. ANY CONSTRUCTION INVOLVED WITHIN 3m OF SURVEY MONUMENTATION WHICH MIGHT ENDANGER THAT MONUMENTATION, SHOULD CONTACT THE FSS-LAND SURVEYING SECTION @ (403) 268-1640, FIVE (5) WORKING DAYS IN ADVANCE FOR LOCATION, AND AFTER THE WORK IS COMPLETED FOR POSSIBLE MOVEMENT.
- B. IF TRENCH WORK IS GOING TO BE CLOSER THAN 1.5m. REMOVAL AND BACKFILLING, MUST BE CARRIED OUT MANUALLY.
- C. NOT MORE THAN 0.30m OF A SURVEY CONTROL MONUMENT IS TO BE EXPOSED. IF SO REFER TO NOTE A ABOVE.
- ⚠ D. IF THE SURVEY CONTROL MONUMENT IS GOING TO BE TEMPORARILY COVERED WITH FILL OR ANY OTHER MATERIAL, A SEWER INTERMEDIATE BARREL & LID OR COVER (SEE SHEET #8, DWG. 452.1001.022) SHOULD BE PLACED TO PROTECT MONUMENT.
- ⚠ E. IF ANY HEAVY EQUIPMENT WORKING WITHIN 10m OF A SURVEY CONTROL MONUMENT, THE JOB FOREMAN IS REQUIRED TO LOCATE A GUARD POST AND A SEWER INTERMEDIATE BARREL (SEE NOTE 'D'), TO PROTECT THE SURVEY CONTROL MONUMENT DURING CONSTRUCTION.

DIMENSIONS ARE IN MILLIMETRES
UNLESS OTHERWISE NOTED

No.	Date	Revision	App'd
3	2016/07/13	REVISED NOTE A	M.C.
2	2004/12/13	REVISED NOTE E	
1	2004/11/23	REVISED NOTE D	

Date
2004/11/01
Scale
N.T.S.

Approved by
AS
for The City of Calgary

SEWER CONSTRUCTION

**ALBERTA SURVEY CONTROL
MONUMENT PROTECTION
STANDARD**

Sheet
54
File Number
481.1002.001

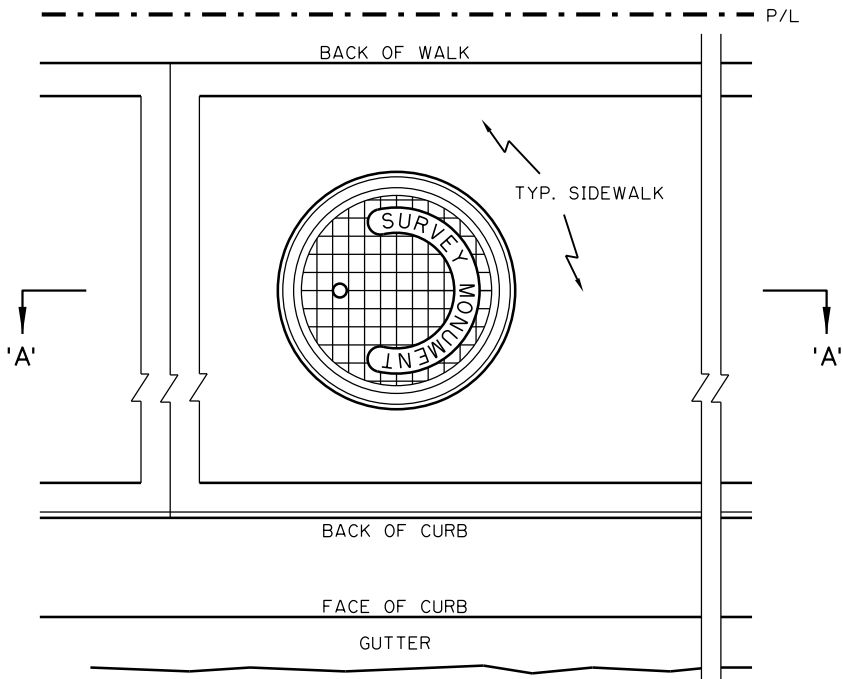

**MANHOLE INSTALLATION
PLAN VIEW**

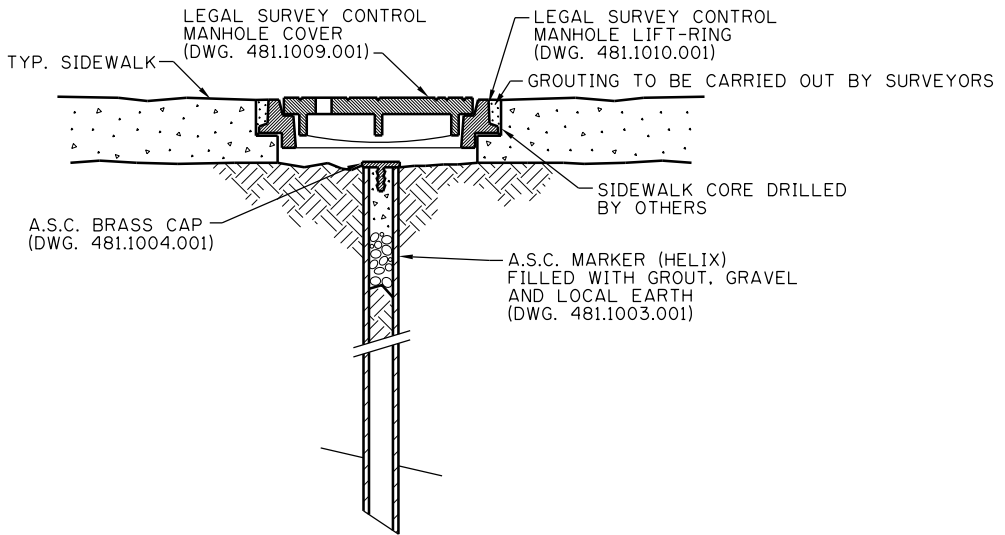

SECTION 'A-A'

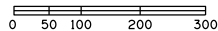

DIMENSIONS ARE IN MILLIMETRES
UNLESS OTHERWISE NOTED

No.	Date	Revision	App'd

Date
1985/10/01

Scale
N.T.S.

Approved by
[Signature]

for The City of Calgary

SEWER CONSTRUCTION

**LEGAL SURVEY CONTROL
TYPICAL SIDEWALK
MANHOLE INSTALLATION**

Sheet
55

File Number
481.1007.001

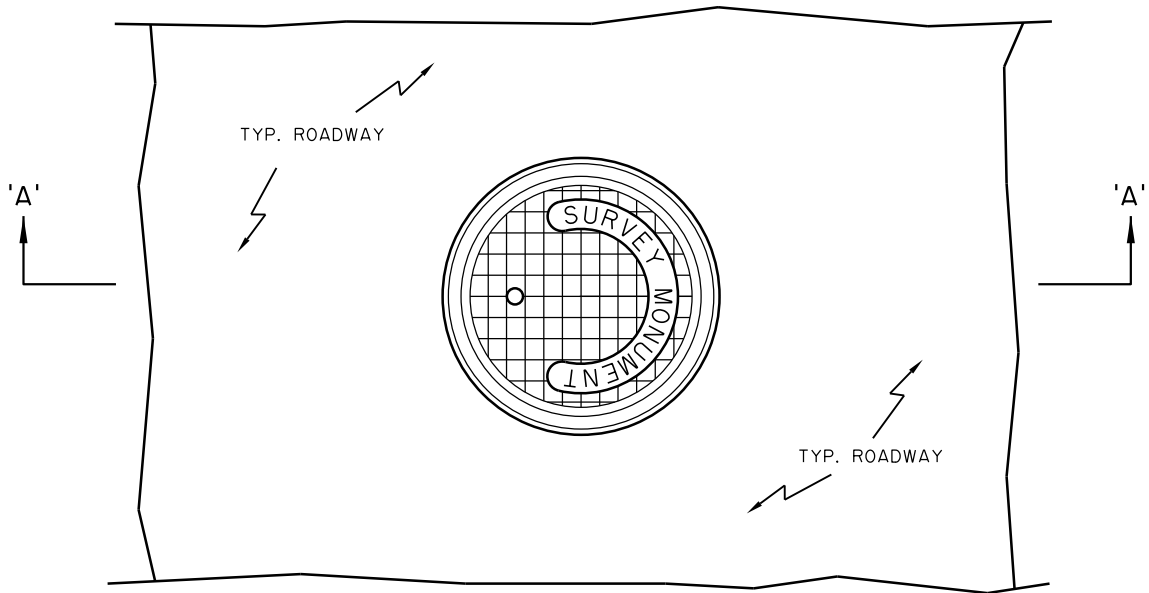

**MANHOLE INSTALLATION
PLAN VIEW**

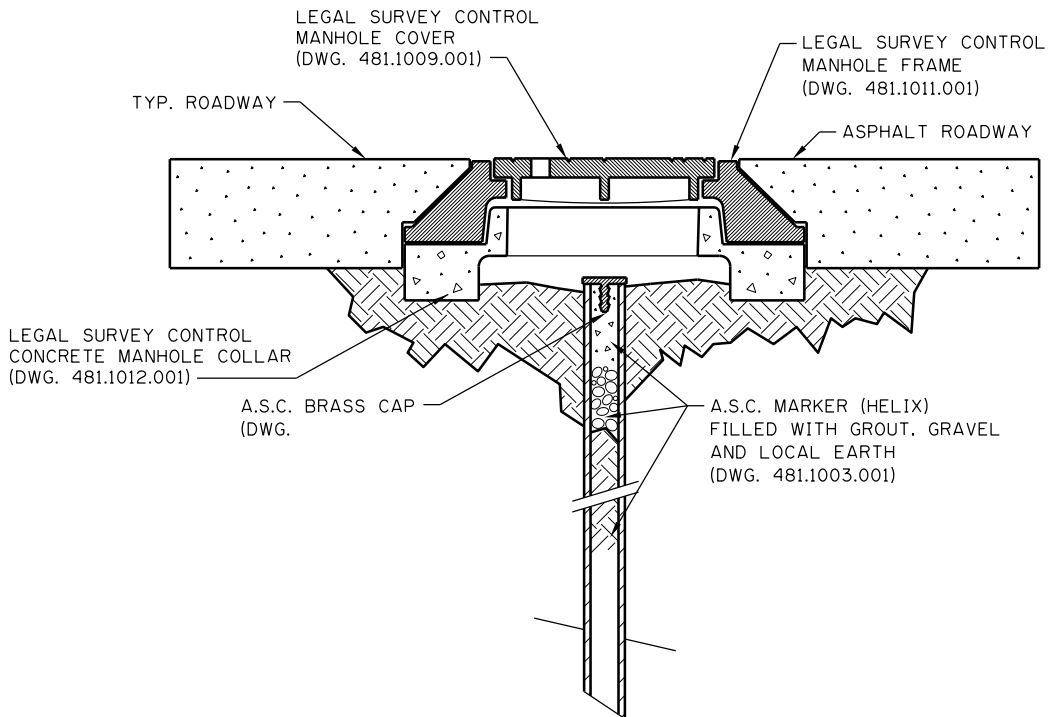

SECTION 'A-A'

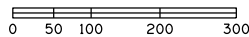

DIMENSIONS ARE IN MILLIMETRES
UNLESS OTHERWISE NOTED

No.	Date	Revision	App'd

Date
1985/10/02

Scale
N.T.S.

Approved by
[Signature]

for The City of Calgary

SEWER CONSTRUCTION

**LEGAL SURVEY CONTROL
TYPICAL ROADWAY
MANHOLE INSTALLATION**

Sheet
56

File Number
481.1008.001

FOR THE CITY OF CALGARY LOGO SPECIFICATIONS SEE "THE CITY OF CALGARY VISUAL IDENTITY GUIDELINES" ON THE CITY OF CALGARY WEBSITE (RED & GREY COLOUR VERSION)

600mm

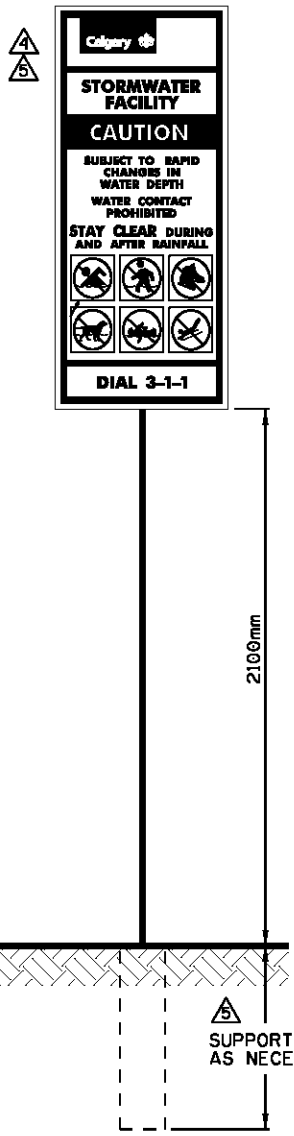

SIGN HEIGHT

Calgary

STORMWATER FACILITY

CAUTION

SUBJECT TO RAPID CHANGES IN WATER DEPTH

WATER CONTACT PROHIBITED

STAY CLEAR DURING AND AFTER RAINFALL

DIAL 3-1-1

WHITE

BLACK 45mm LETTERS

WHITE 60mm LETTERS

BLUE 30mm LETTERS

RED 30mm LETTERS

RED

BLACK 45mm LETTERS

WHITE

RED

WHITE

RED 40mm LETTERS

1400mm

RED CIRCLE AND SLASH

BLACK IMAGE

BLACK 150mm

WHITE

SUPPORT DEPTH AS NECESSARY

NOTE:

- * SIGNS WILL BE MOUNTED AT 2.10m ABOVE THE FINISH GRADE OF ADJACENT SIDEWALK AND BE PLACED AT ACCESS ENTRANCE TO THE STORM POND AS APPROVED BY WATER RESOURCES / WATER SERVICES
- * COLOUR TO BE ENGINEER GRADE SCOTCHLITE

DIMENSIONS ARE IN MILLIMETRES UNLESS OTHERWISE NOTED

No.	Date	Revision
5	2017/12/07	ADDED NO TOBOGGANING SIGN & SUPPORT DEPTH FOR SIGN
4	2017/09/06	REPLACED COC LOGO, REVISED NOTES AND ADDED DETAIL
3	2012/12/01	ADDED PROHIBITED DOG & BOAT IMAGES
2	2008/05/01	ADDED COC LOGO AND 3-1-1
1	2005/10/01	WASTEWATER CHANGED TO WATER RESOURCES/WATER SERVICES

Date: 2002/04/16
 Scale: N.T.S.
 Approved by:

SEWER CONSTRUCTION

STORMWATER STORAGE SITE SIGN 100

Sheet **57**
 File Number 452.1043.001

DRAWINGS 57A & 57B: DELETED

Contact Water Services for Stormwater Storage Site Sign information requests.

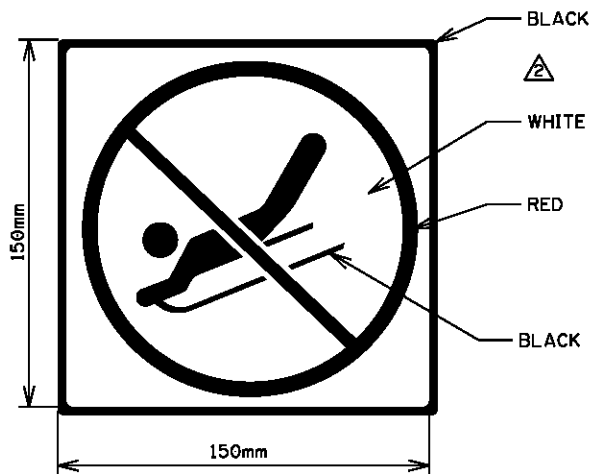
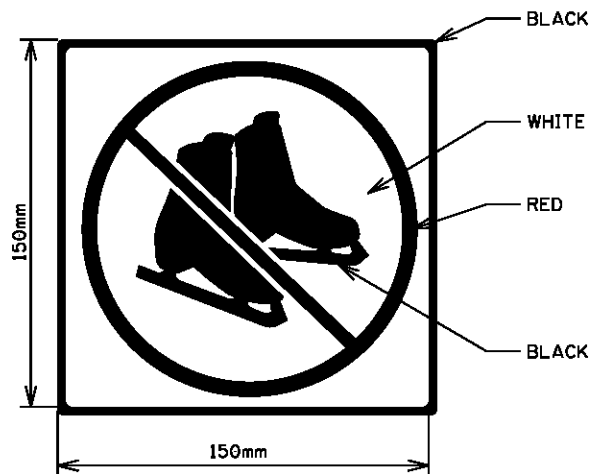
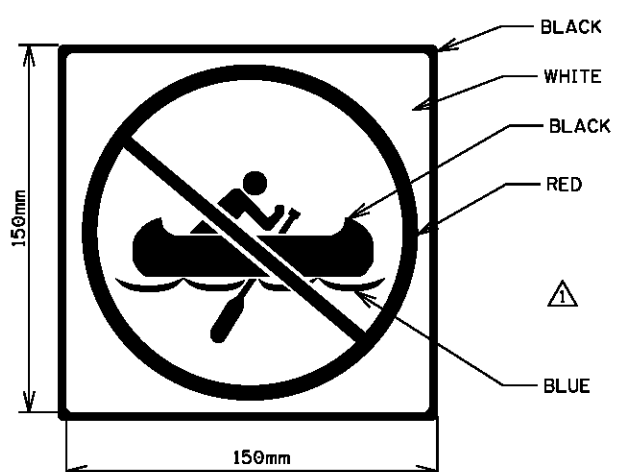
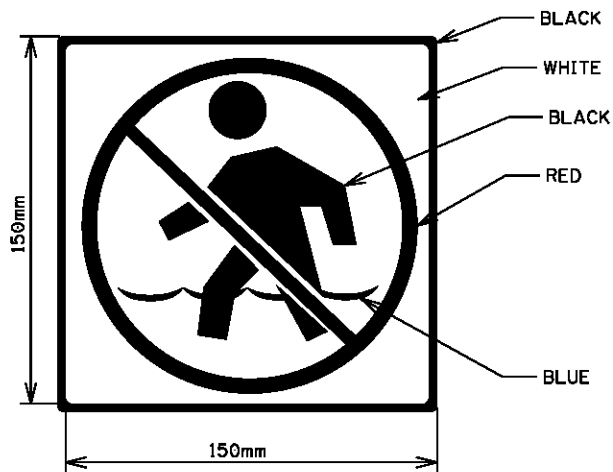
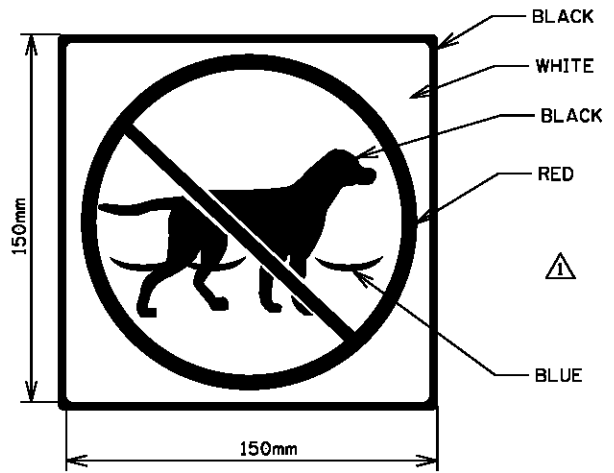
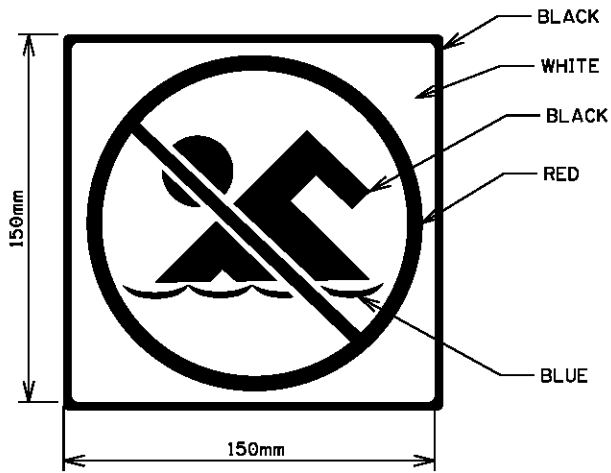

NOTE:

- TO ACCOMPANY SIGNS NO. 100 (SHEET 57)
- COLOUR TO BE ENGINEER GRADE SCOTCHLITE

DIMENSIONS ARE IN MILLIMETRES
UNLESS OTHERWISE NOTED

No.	Date	Revision
2	2017/11/29	ADDED NO TOBOGGANING IMAGE
1	2012/12/01	ADDED PROHIBITED DOG & BOAT IMAGES

Date
2002/04/16

Scale
N.T.S.

Approved by
AS

App'd for The City of Calgary

SEWER CONSTRUCTION

**STORMWATER STORAGE
SITE SIGN 400**

Sheet
57C

File Number
452.1043.004

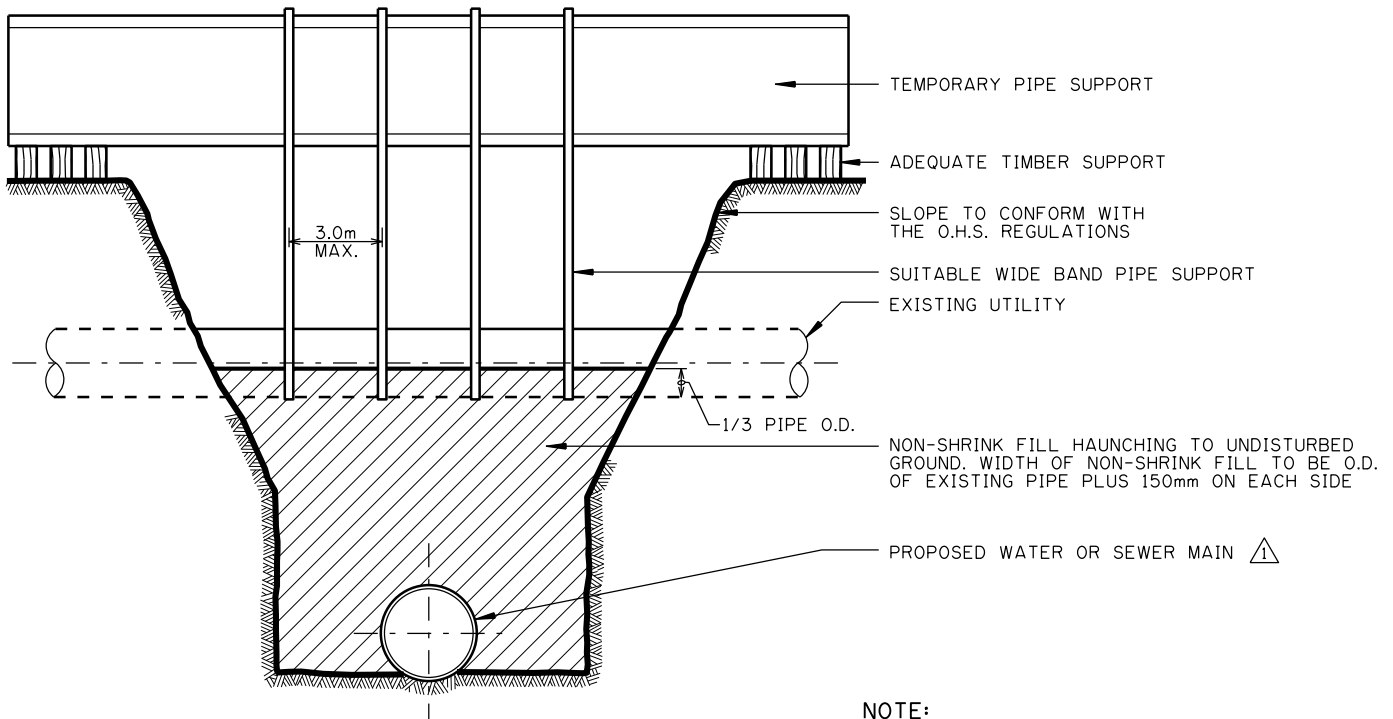

**PIPE INSTALLATION CROSSING
BELOW AN EXISTING UTILITY**

NOTE:

1. WHEN THE EXISTING UTILITY IS OTHER THAN A WATER OR SEWER MAIN, APPROVAL OF THE CROSSING DETAIL MUST BE OBTAINED FROM THE UTILITY CONCERNED.
2. ALL ELEMENTS OF THE TEMPORARY SUPPORT SYSTEM MUST BE DESIGNED BY A PROFESSIONAL ENGINEER.
3. PROVIDE 2-PLY 15 MIL POLY FILM TO PREVENT BONDING OF CONCRETE TO PIPE.
4. NO JOINTS SHALL BE INSTALLED IN THE ENCASED AREA.
5. A FLEXIBLE JOINT SHALL BE PROVIDED WITHIN 1 METRE OUTSIDE OF THE CONCRETED ENCASED UTILITY ON EACH SIDE.

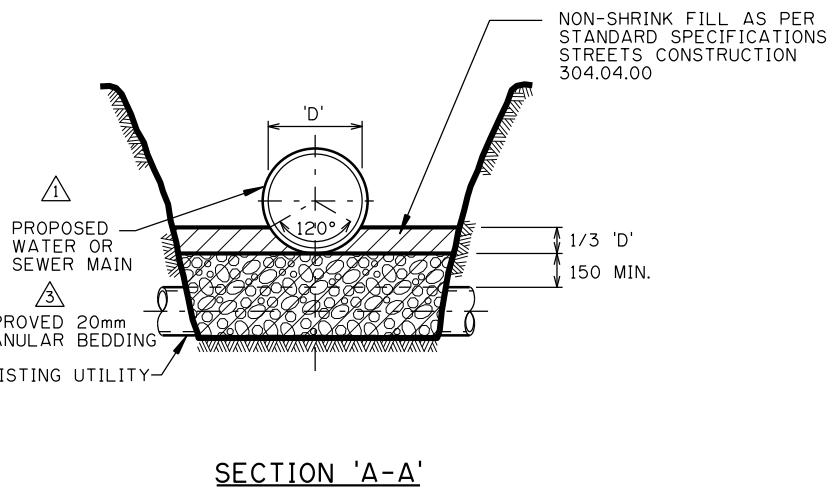
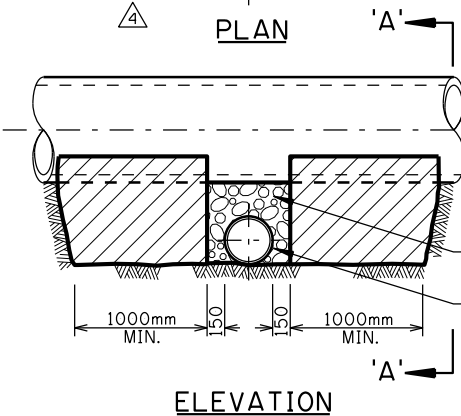
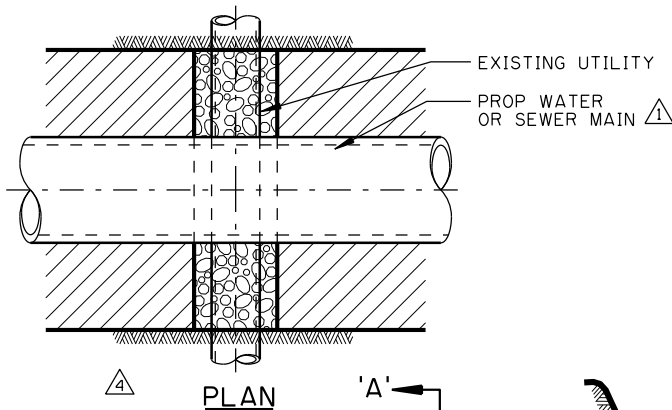

**PIPE INSTALLATION CROSSING
ABOVE AN EXISTING UTILITY**

DIMENSIONS ARE IN MILLIMETRES
UNLESS OTHERWISE NOTED

No.	Date	Revision
4	2012/01/20	REVISED DRAWING
3	2012/01/20	ADDED GRANULAR BEDDING
2	2012/01/20	ADDED NOTES 3 TO 5
1	2012/01/20	REVISED LABEL

Date	1999/09/14
Scale	N.T.S.
Approved by	<i>[Signature]</i>
App'd	for The City of Calgary

SEWER CONSTRUCTION
PIPE SUPPORT AT UTILITY CROSSING

Sheet	58
File Number	452.1044.001

NOTES:

1. AT LEAST ONE PLUG IS REQ'D IN EACH PHASE OF A SUBDIVISION. AT THE LOWEST POINT IN THE STORM SEWER SYSTEM.
2. GROUNDWATER PLUGS SHALL BE SUITABLE CLAY OR CONTROL DENSITY FILL AS PER ROADS CONSTRUCTION STANDARD 304.05.00

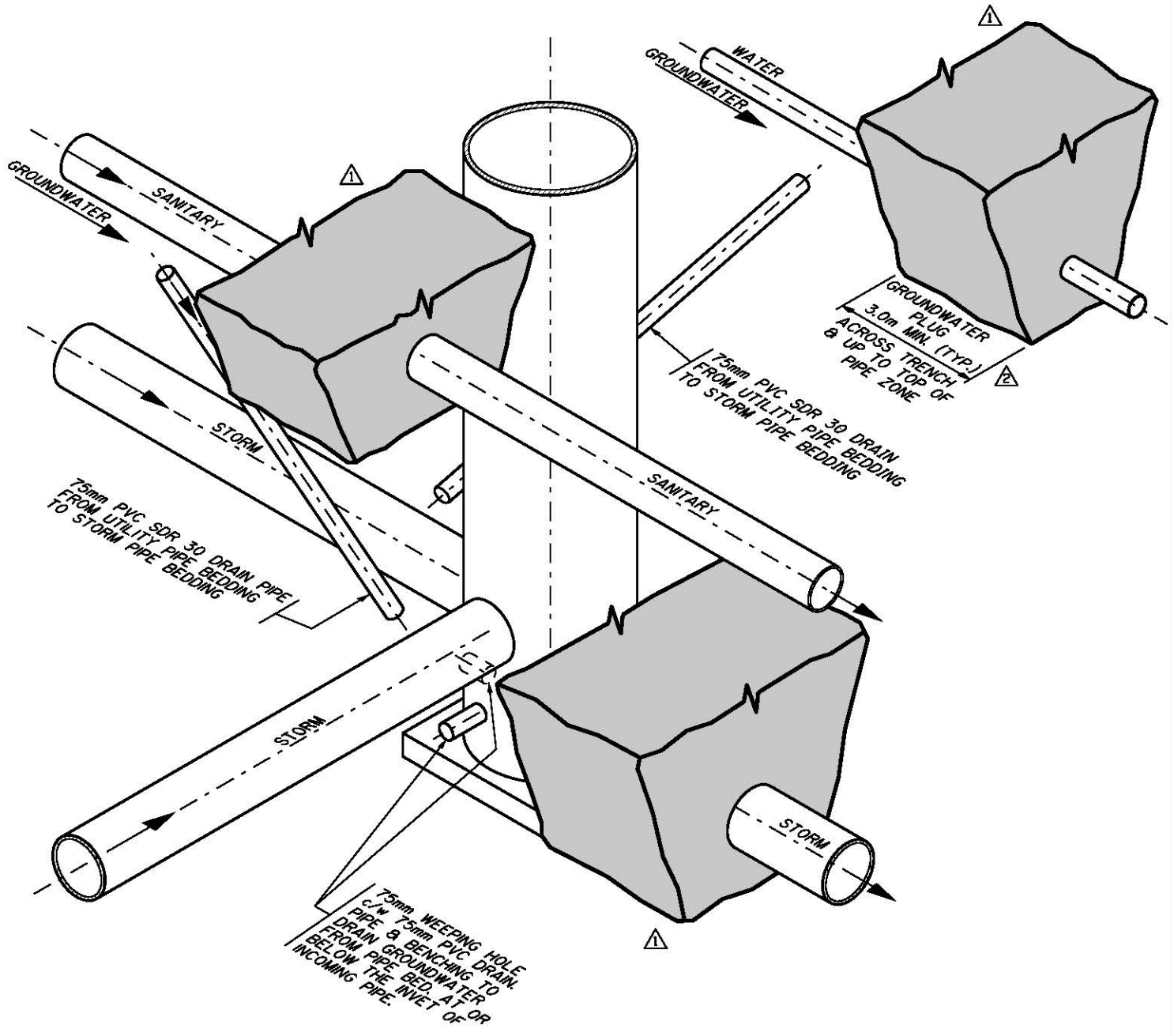

DIMENSIONS ARE IN MILLIMETRES UNLESS OTHERWISE NOTED

No.	Date	Revision
2	2018/03/01	MODIFIED NOTES AND TITLE BLOCK
1	2008/02/15	ADD SHADING

Date: 1992/01/01
 Scale: N.T.S.
 Approved by: *AS*
 for The City of Calgary

SEWER CONSTRUCTION

GROUND WATER PLUGS & WEEPING HOLES AT STORM MANHOLES

Sheet **59**
 File Number 452.1005.006

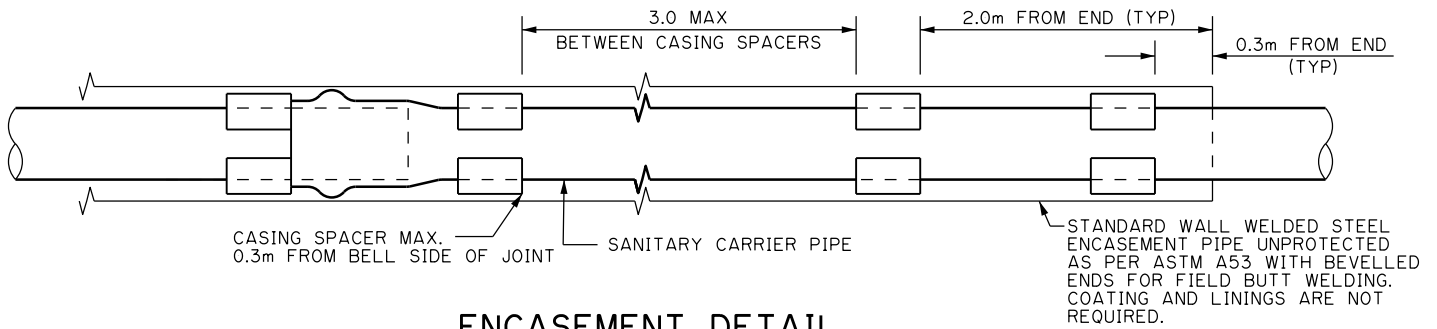

ENCASEMENT DETAIL

NOTE: FOR CARRIER PIPE

- 1) SOLID WALL PVC ONLY IS PERMITTED. NO PROFILE PIPE.
- 2) FOR PVC PIPE, THE SPACER ON THE SPIGOT END SHALL BE PLACED IN LINE WITH THE INSERTION MARK, TO PREVENT THE SPIGOT FROM TRAVELLING INTO THE BELL BEYOND THE INSERTION MARK.
- 3) THE SPACER RUNNERS SHALL BE AT LEAST 10mm > THAN THE BELL HEIGHTS TO ENSURE THE PIPE IS NOT SUPPORTED ON THE BELL.
- 4) ENDS OF THE CASING SHALL BE COVERED WITH SUITABLE FABRIC, PSI MODEL "C" END SEAL OR APPROVED EQUAL TO THE SATISFACTION OF THE ENGINEER.
- 5) FOR CATHODIC PROTECTION OF STEEL ENCASEMENT PIPE AND FOR TEST POINT REQUIREMENTS, PLEASE REFER TO SHEET *15 OF THE STANDARD SPECIFICATION, WATERWORKS CONSTRUCTION.

FOR PVC, STEEL, AND CONCRETE CARRIER PIPE THE FOLLOWING SPACERS SHALL BE USED:

NOMINAL CARRIER PIPE DIAMETER	SPACER LENGTH (MINIMUM)	RUNNER WIDTH (MINIMUM)	MANUFACTURER	TYPE /MODEL
150 – 600 mm	200 mm	25 mm	BWM	SS-8
			APS	SSI-8
			CCI-Pipeline Supply International	CSS8
			Silvertip / Martech	SSBM8
600 – 1200 mm	300 mm	50 mm	BWM	SS-12
			APS	SSI-12
			CCI-Pipeline Supply International	CSS12
			Silvertip / Martech	SSBM12

(THE SKID HEIGHT SHALL BE AT LEAST 10mm > THAN THE BELL HEIGHT)
 *A12G2 ALSO PERMITTED FOR CONCRETE IF SO DESIRED.
 **MODEL SIM. 200mm SPACER LENGTH IS ACCEPTABLE FOR 450-600mm PVC or PE CARRIER PIPES ONLY.

CARRIER PIPE NOMINAL INSIDE DIAMETER (mm)	ENCASEMENT PIPE MINIMUM NOMINAL DIAMETER (mm)	
	PVC OR STEEL	CONCRETE
150	300	300
200	400	450
250	450	500
300	500	600
375	660	710
450	750	810
525	810	910
600	865	1015
675	965	1115
750	1220	1220
900	1270	1420
1050	1320	1575
1200	1370	1625

CARRIER PIPES GREATER THAN 1200mm REQUIRE APPROVAL BY THE ENGINEER

DIMENSIONS ARE IN MILLIMETRES UNLESS OTHERWISE NOTED

5	2014/04/23	CHANGED PIPE DIAMETER, MANUFACTURER AND TYPE/MODEL LIST	Date 1999/07/06	 Approved by for The City of Calgary	SEWER CONSTRUCTION ENCASEMENT PIPE DETAIL	Sheet 60
4	2008/11/05	NOTE 5 ADDED	Scale N.T.S.			File Number 452.1016.001
3	2007/08/23	SOLID WALL PVC ONLY IS PERMITTED NO PROFILE PIPE				
2	2005/05/10	SOLID WALL PVC ONLY IS PERMITTED NO PROFILE PIPE				
1	2004/11/10	REMOVE PE ENCASEMENT PIPE FROM TABLE				
No.	Date	Revision	App'd			

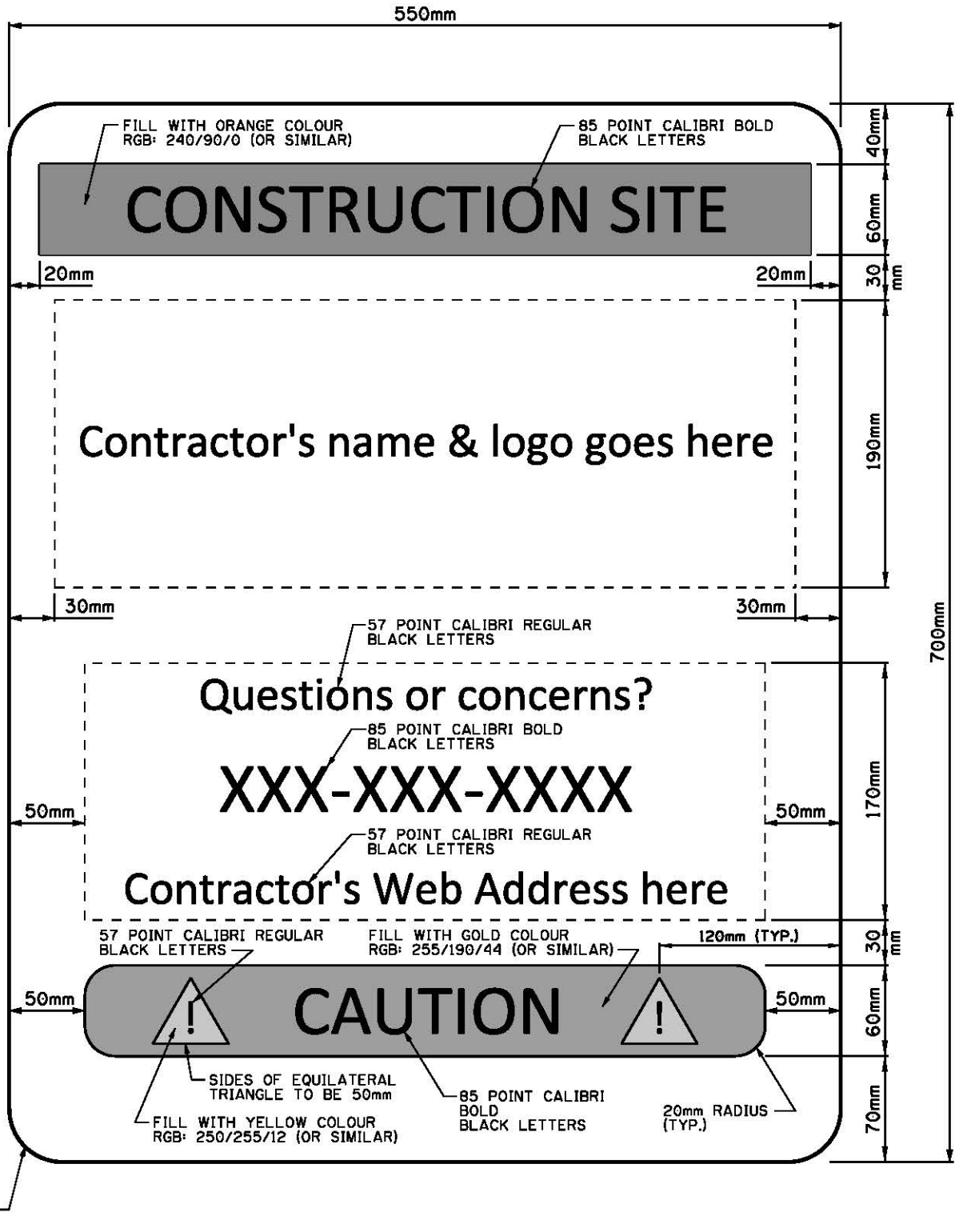

NOTE:

- THE BACKGROUND IS TO BE WHITE

DIMENSIONS ARE IN MILLIMETRES
UNLESS OTHERWISE NOTED

No.	Date	Revision
3	2019/06/03	WHOLE DRAWING REVISED
2	2018/02/05	REVISED TITLE FOR SIGN & MODIFIED SPACE FOR LOGO
1	2016/07/28	REVISED CITY LOGO AND SIGN

Date
2001/04/10

Scale
N.T.S.

Approved by
M. Chapman

App'd for The City of Calgary

SEWER CONSTRUCTION

PORTABLE OR
FREE STANDING
CONSTRUCTION SIGN

Sheet
61

File Number
452.1047.002

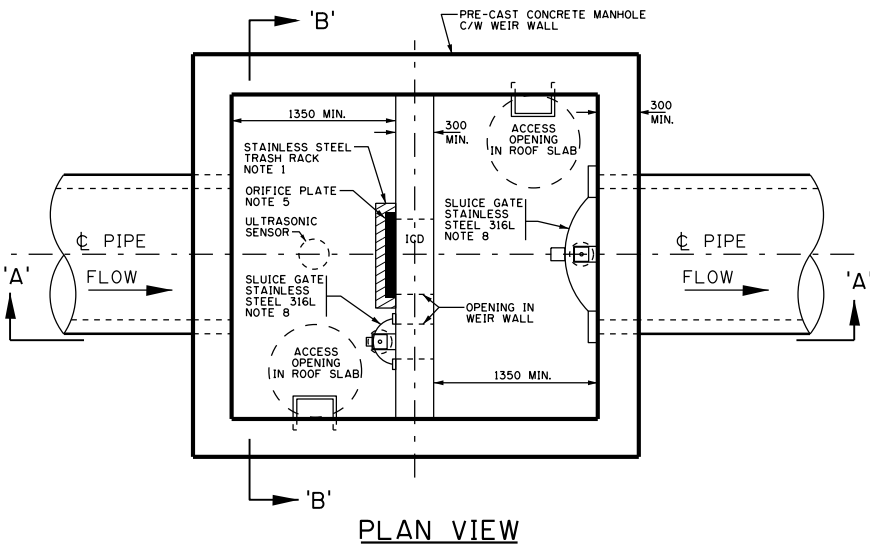

PLAN VIEW

NOTES:

1. TRASH RACK FASTENED TO THE WEIR WALL WITH SS HARDWARE, SPACING AS PER STORMWATER MANAGEMENT & DESIGN MANUAL, LATEST EDITION.
2. SENSOR / INSTRUMENTATION WIRING AND CONDUIT MUST FACILITATE REMOVAL OF SLAB TOP.
3. HIGH LEVEL FLOAT SWITCH MOUNTED WHERE IT CAN BE TESTED FROM ABOVE GROUND.
4. CORROSION RESISTANT BOXES MOUNTED WITH STAINLESS HARDWARE ON CORROSION RESISTANT STRUT WHERE NEEDED.
5. ORIFICE PLATE SECURED TO THE WALL WITH SS 304 M12 BOLTS AND INSERT ANCHORS. WATERPROOF SEAL BETWEEN THE PLATE AND WALL.
6. GEARED LIFT C/W T-WRENCH STORED IN MANHOLE STEPS AND REACHABLE FROM ABOVE GROUND.
7. ELEVATION AS PER STORMWATER MANAGEMENT AND DESIGN MANUAL LATEST EDITION.
8. C/W SS OPERATING ROD MECHANISM.
9. C/W SS LIFT HOOKS.
10. MANHOLE STEPS PE COATED ALUMINUM RUNGS NON SLIPPED, INSTALLATION AS PER SHEET 9, STANDARD SPECIFICATIONS, SEWER CONSTRUCTION, LATEST EDITION, SPACING AT 400mm.
11. MANHOLE FRAME AS PER SHEET *4, STANDARD SPECIFICATIONS SEWER CONSTRUCTION, LATEST EDITION, "STORMWATER" COVER.
12. PRECAST STRUCTURE IN CONFORMANCE TO ASTM C-478 & CSA A257.4
13. STRUCTURAL DESIGN BASED ON CL800 TRUCK LOAD.
14. TYPE HS (50) CEMENT TO CSA A3001 OR TYPE V TO ASTM C150.
15. CONCRETE COMPRESSIVE STRENGTH 35 MPa @ 28 DAYS, AIR CONTENT 4% TO 7% EXCEPT WHERE NO SLUMP CONCRETE IS USED.
16. REINFORCING STEEL DEFORMED BARS TO CSA G30.18.

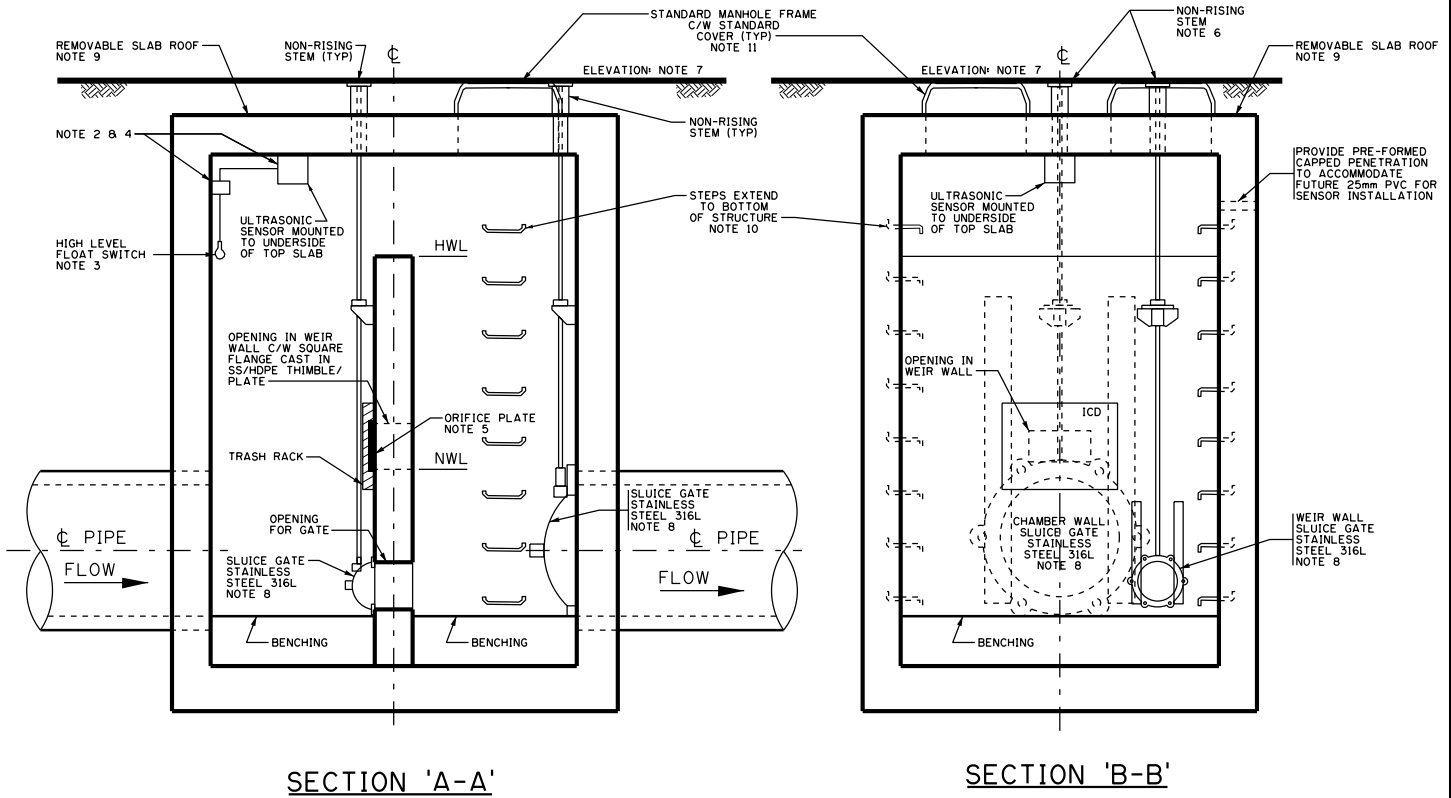

SECTION 'A-A'

SECTION 'B-B'

DIMENSIONS ARE IN MILLIMETRES UNLESS OTHERWISE NOTED

No.	Date	Revision	M.C.	App'd
1	2020/02/10	CONCRETE STRENGTH REVISED		

Date
2019/12/03

Scale
N.T.S.

Approved by
M. Chapman
for The City of Calgary

SEWER CONSTRUCTION

OUTLET CONTROL STRUCTURE

Sheet
62

File Number
452.2005.001

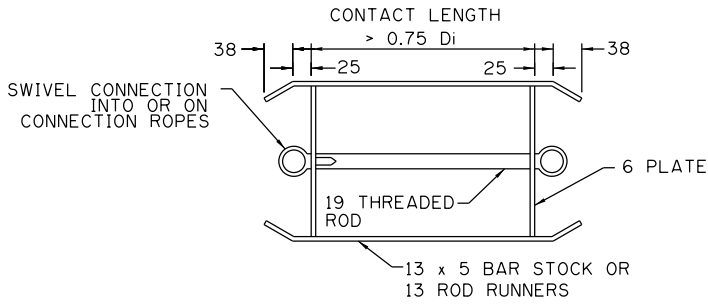

LONGITUDINAL SECTION OF MANDREL

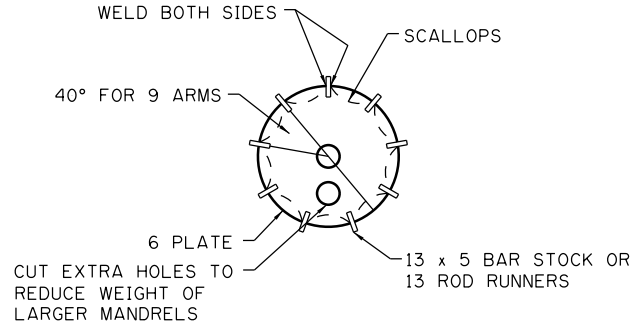

TRANSVERSE SECTION OF MANDREL

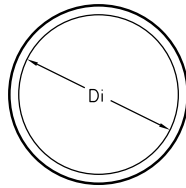

END VIEW OF PROVING RING

NOTE:

MANDRELS LARGER THAN 450 mm IN DIAMETER SHALL BE CONSTRUCTED OF SPECIAL BREAKDOWN DEVICES TO FACILITATE ENTRY THROUGH ACCESS MANHOLES.

MANDREL SIZING FOR SOLID WALL SDR35 PVC PIPE

NPS (1)	RADIUS OF MANDREL ARM (mm)	
	SHORT TERM 5.0%	LONG TERM 7.5%
200	93.7	91.4
250	117.1	114.3
300	139.4	136.0
375	170.6	166.5
450	208.5	203.5
525	245.8	239.9
600	276.6	269.9
675	311.7	304.2
750	357.1	348.5
900	427.3	417.0
1050	496.4	484.5

3

NOTES:

- NPS MEANS NOMINAL PIPE SIZE.
- MANDRELS MUST BE CONSTRUCTED WITHIN ±0.25mm OF THE SPECIFIED SIZE.
- THE REQUIRED 'RADIUS OF MANDREL ARM' SPECIFIED HEREIN HAS BEEN CALCULATED TO ACCURATELY TEST FOR SHORT TERM (5%) AND LONG TERM (7.5%) ALLOWABLE VERTICAL DEFLECTION TAKING INTO ACCOUNT THE NINE ARM MANDREL DESIGN SPECIFIED AND THE OVAL SHAPE OF A DEFLECTED PIPE. NOTE THAT THE RADII SPECIFIED ARE SLIGHTLY LARGER THAN RADII BASED STRICTLY ON CSA OR ASTM BID (BASE INSIDE DIAMETERS).
- BEFORE EACH USEAGE MANDRELS SHALL BE TESTED WITH A PROVING RING CERTIFIED BY WATER RESOURCES.
- EITHER A DUAL PURPOSE GO/NO GO PROVING RING OR TWO SEPARATE RINGS, AN 'OVERSIZE' AND AN 'UNDERSIZE', SHALL BE USED. AN 'OVERSIZE' RING SHALL BE THE DIAMETER OF THE MANDREL PLUS 1mm WITHIN A TOLERANCE OF 0.25mm. AN 'UNDERSIZE' RING SHALL BE BETWEEN 0.10 AND 0.30mm LESS THAN THE SPECIFIED MANDREL SIZE.
- SEE ALSO SECTION 403.13.04 DEFLECTION TESTING

PROFILE WALL PVC PIPE PS 320KP₀

NPS (1)	RADIUS OF MANDREL ARM (mm) (2)	
	SHORT TERM 5.0%	LONG TERM 7.5%
200	93.7	91.4
250	117.1	114.3
300	139.4	136.0
375	170.6	166.5
450	209.5	204.5
525	246.3	240.4
600	279.0	272.3
675	314.9	307.4
750	350.6	342.1
900	421.9	411.7
1050	493.2	481.3

3

DIMENSIONS ARE IN MILLIMETRES UNLESS OTHERWISE NOTED

No.	Date	Revision	App'd
3	2016/03/24	TABLE DATA REMOVED	MC
2	2006/09/18	TABLE DATA REMOVED	
1	2006/09/18	NOTES 1 TO 6 ADDED	

Date
2004/11/15
Scale
N.T.S.
Approved by
AS
for The City of Calgary

SEWER CONSTRUCTION
MANDREL DESIGN & SIZING

Sheet
63
File Number
452.1016.002

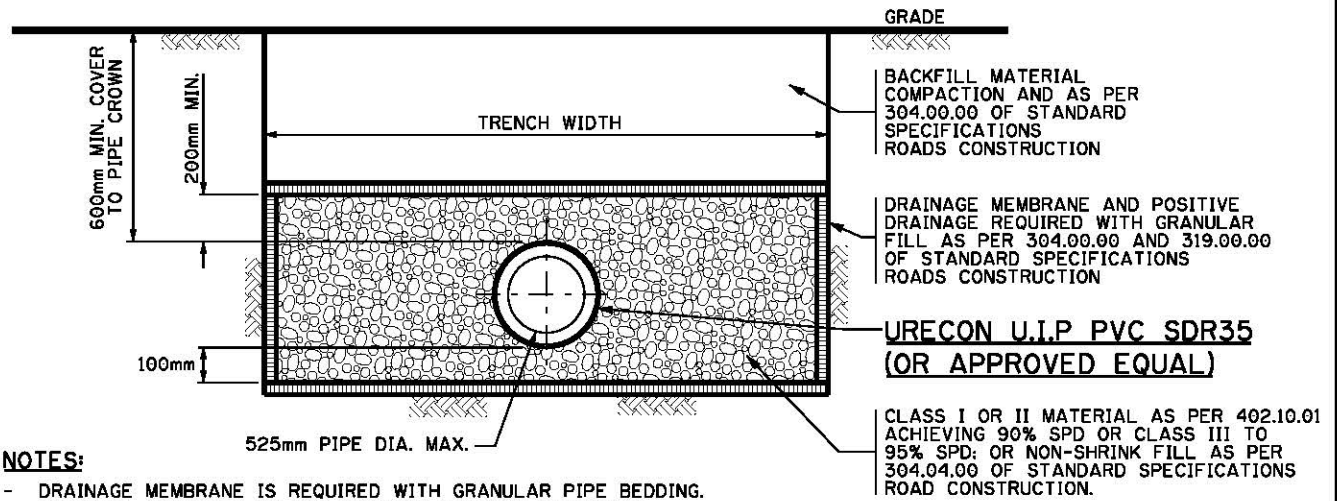

NOTES:

- DRAINAGE MEMBRANE IS REQUIRED WITH GRANULAR PIPE BEDDING.
- APPROVAL REQUIRED AS PER 403.05.10 CURRENT STANDARD SPECIFICATIONS SEWER CONSTRUCTION.
- 2 PLY OF 0.15mm POLYETHYLENE WRAP SHALL BE PLACED BETWEEN PIPE AND NON-SHRINK FILL.

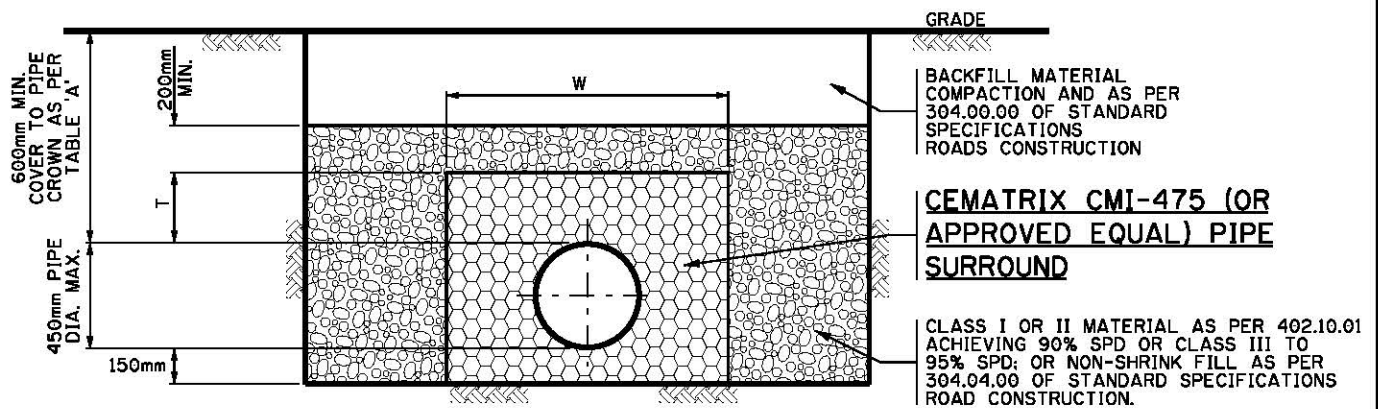

COVER TO PIPE CROWN (m)	CEMATRIX ENCASEMENT	
	W (mm)	T (mm)
0.60-1.2	1200	300

NOTES:

- DRAINAGE MEMBRANE NOT REQUIRED.
- FORMWORK TO BE CONSTRUCTED BY THE CONTRACTOR AS REQUIRED.
- APPROVAL REQUIRED AS PER 403.05.10 CURRENT STANDARD SPECIFICATIONS SEWER CONSTRUCTION.
- 2 PLY OF 0.15mm POLYETHYLENE WRAP SHALL BE PLACED BETWEEN PIPE AND CEMATRIX.
- MINIMUM 28 DAY COMPRESSIVE STRENGTH = 400 KPa.

DETAIL 'A' - CEMATRIX CMI-475 INSULATING CELLULAR CONCRETE PIPE SUPPORTS

TO COUNTERACT BUOYANCY, FILL PIPE WITH WATER PRIOR TO CELLULAR CONCRETE PLACEMENT. CELLULAR CONCRETE MUST BE PLACED IN ONE CONTINUOUS POUR.

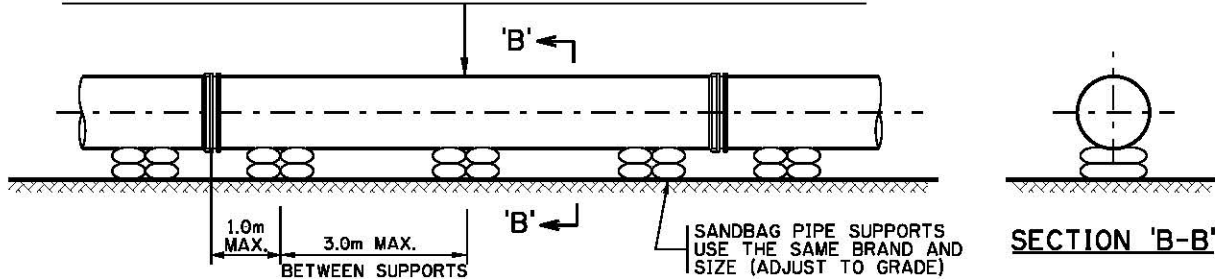

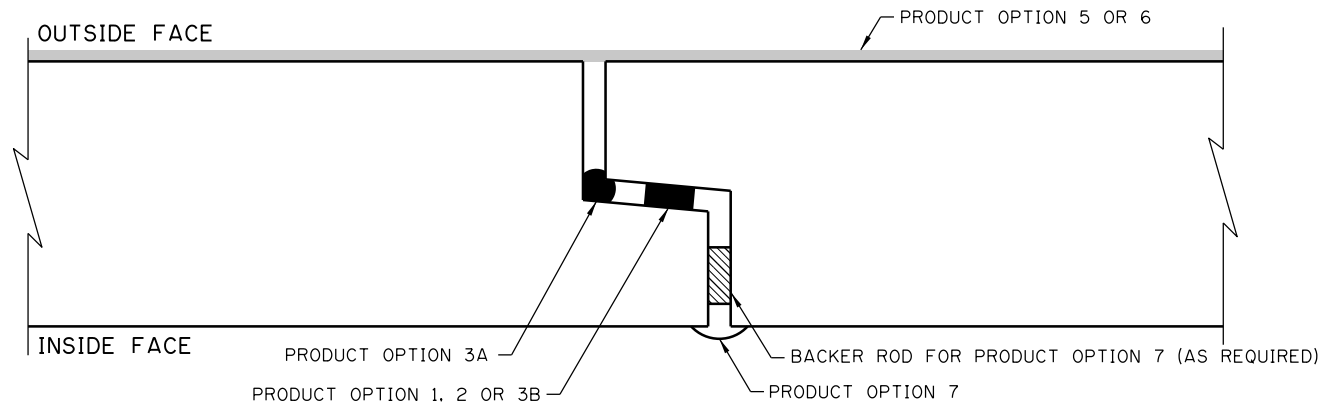

DIMENSIONS ARE IN MILLIMETRES UNLESS OTHERWISE NOTED

		Date 2017/02/08		SEWER CONSTRUCTION	Sheet
		Scale N.T.S.			64
		Approved by		SHALLOW BURY STORM INSULATION	File Number
1	2018/03/07	REVISED TITLE BLOCK NAME			MC
No.	Date	Revision	App'd	for The City of Calgary	

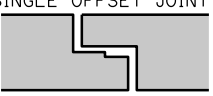

TYPICAL PRODUCT OPTION PLACEMENT

EXPECTED WATER PRESSURES	BOX SECTION JOINT TYPE TONGUE AND GROOVE JOINT  SINGLE OFFSET JOINT 	JOINT TREATMENT PRODUCT COMBINATIONS	JOINT TREATMENT PRODUCTS OPTIONS								
			BUTYL RUBBER SEALANT (SEE NOTE 1)	GASKET (SEE NOTE 2 AND 3)	EXPANDING (HYDROPHILIC) WATERSTOP -EXTRUDABLE FORM	EXPANDING (HYDROPHILIC) WATERSTOP -ROPE FORM	GEOTEXTILE FILTER FABRIC	EXTERNAL SEALING BAND	WATERPROOFING MEMBRANE OR COATING	ELASTOMETRIC SEALANT (SEE NOTE 4)	
			1	2	3A	3B	4	5	6	7	
34kPa (5psi) OR 3.5m (11.5ft) HYDROSTATIC HEAD	TONGUE AND GROOVE JOINT	1	X ¹					X			
	SINGLE OFFSET JOINT	2			X	X					
		3	X ¹				X				
		4		X ²			X				
90kPa (13psi) OR 9.1m (30.0ft) HYDROSTATIC HEAD	TONGUE AND GROOVE JOINT	5			X	X					
	SINGLE OFFSET JOINT	6			X		X		X ⁴		
		7			X			X	X ⁴		
		8		X ^{2,3}	X			X	X ⁴		
		9		X ^{2,3}	X			X	X ⁴		
10				X		X	X ⁴				
11				X		X	X ⁴				
GREATER THAN: 90kPa (13psi) OR 9.1m (30.0ft) HYDROSTATIC HEAD	TONGUE AND GROOVE JOINT	SEE NOTE 5									
	SINGLE OFFSET JOINT										

NOTES: 

1. PREFORMED SEALANTS MUST BE SIZED AND INSTALLED PER MANUFACTURER'S INSTRUCTIONS.
2. GASKETS MAY NOT BE AVAILABLE ON ALL PRECAST MANUFACTURER'S JOINTS. DISCUSS OPTIONS WITH PRECAST MANUFACTURER.
3. GASKETS ALONE CAN WITHSTAND PRESSURES UP TO 13psi/90kPa WITH SPECIAL JOINT DESIGNS. DISCUSS OPTIONS WITH PRECAST MANUFACTURER.
4. OPTIONAL TO HELP PREVENT EXFILTRATION. REFER TO SEALANT MANUFACTURER'S INSTRUCTIONS FOR BACKER ROD APPLICATION.
5. UNDER HIGH GROUNDWATER LEVEL CONDITIONS, EXPANDING FOAM SEALANTS AT JOINTS CAN BE ADDED TO OPTIONS 6-11 OR AS RECOMMENDED BY THE DESIGN ENGINEER.

DIMENSIONS ARE IN MILLIMETRES UNLESS OTHERWISE NOTED

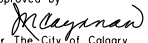
		Date 2017/09/12		SEWER CONSTRUCTION		Sheet 65
		Scale N.T.S.		PRECAST CONCRETE BOX JOINT TREATMENT GUIDELINES		File Number 452.2003.001
1		2017/12/07	NOTES 1-5 REMOVED AND REPLACED WITH NEW NOTES		MC	
No.	Date	Revision	Approved by 		App'd	

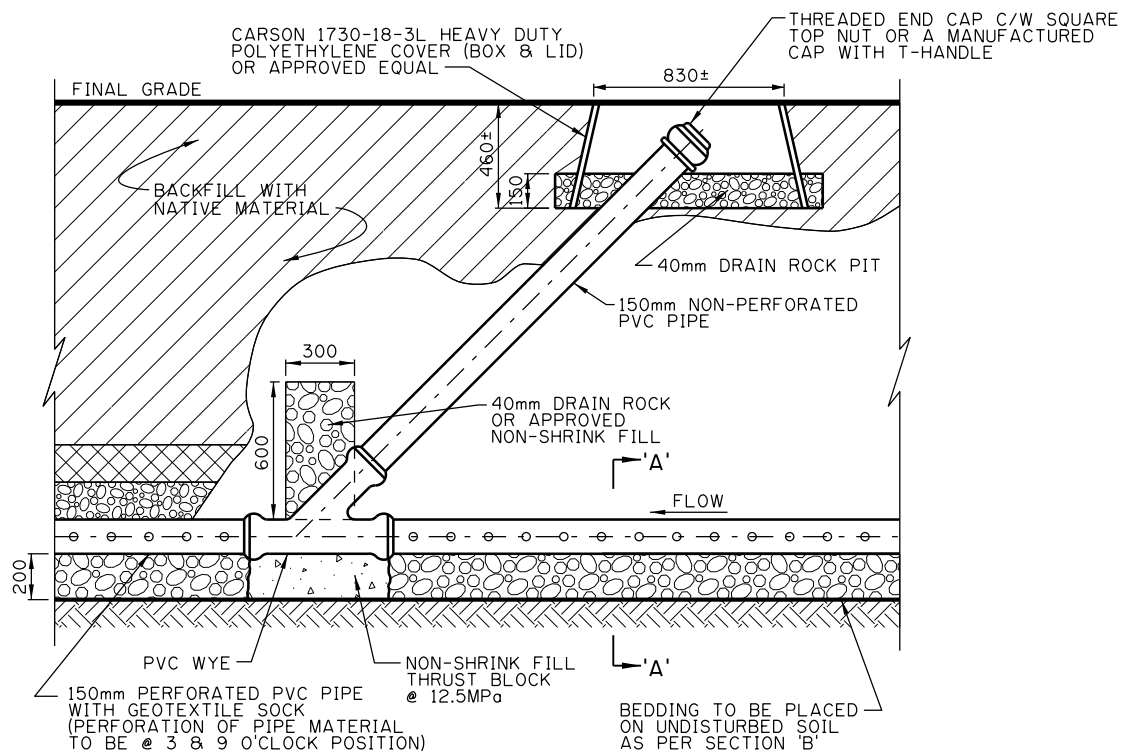

INTERMEDIATE CLEANOUT FOR SUBDRAINS OVER 30m IN LENGTH

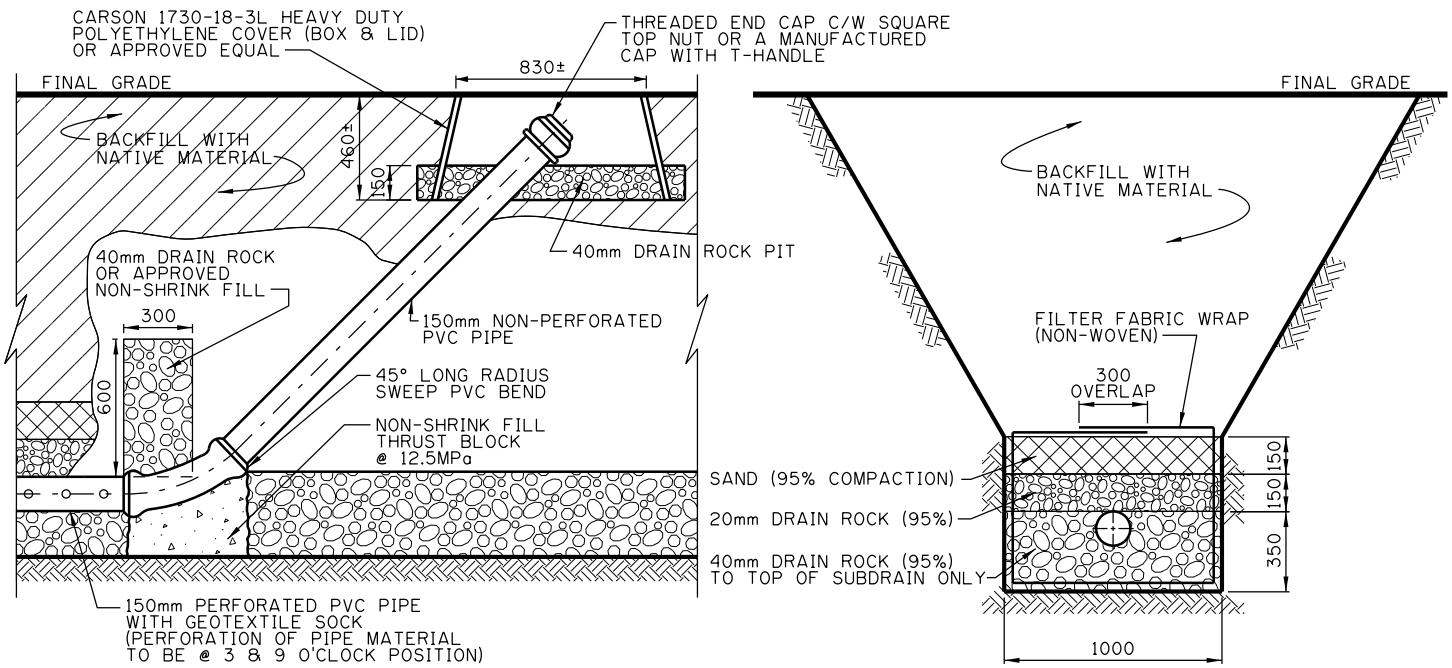

**CLEANOUT - SUBDRAINS
30m IN LENGTH OR LESS**

NOTES:

1. ALL SUBDRAIN PIPE MATERIALS TO BE SDR-35 AND MINIMUM 150mm IN DIAMETER.
2. ALL CLEANOUT MATERIAL TO BE SDR-35.
3. SUBDRAIN TO BE INSTALLED @ 0.5% MINIMUM GRADE.
4. SUBDRAIN TO ENTER IN CATCHBASIN (CORED HOLE) OR STORM MANHOLE PENDING APPROVAL FROM WATER RESOURCES.
5. CLEANOUT 'Y' TO BE PLACED IN UPWARD POSITION.
6. SDR CAP TO BE USED @ END POINTS OF SUBDRAIN.
7. 40mm DRAIN ROCK PIT TO EXTEND 100mm OUTSIDE HEAVY DUTY POLYETHYLENE COVER AND BE 150mm IN DEPTH.
8. HEAVY DUTY POLYETHYLENE COVER TO BE FLUSH WITH FINAL GRADE. PROTRUDING OR SUBMERGED COVERS WILL BE REJECTED.
9. LONG RADIUS SWEEP & CLEANOUT 'Y' TO BE BEDDED IN 40mm DRAIN ROCK OR NON-SHRINK FILL.
10. SUBDRAIN CLEANOUT TO BE PLACED ON 30m INTERVALS & AT END OF SUBDRAIN.
11. NON-PERFORATED PIPE TO BE UTILIZED WHEN OUTSIDE OF BIO-RETENTION AREA.
12. CLEANOUTS TO BE ANGLED IN DOWN STREAM FLOW DIRECTION.
13. ALL BEDDING MATERIAL AS PER CURRENT STANDARD SPECIFICATIONS SEWER CONSTRUCTION.

DIMENSIONS ARE IN MILLIMETRES UNLESS OTHERWISE NOTED

				Date 2020/06/04		SEWER CONSTRUCTION		Sheet
				Scale NTS		SUBDRAIN/CLEANOUT FOR BIORETENTION AREAS		66
				Approved by <i>M. Chapman</i>			File Number	
No.	Date	Revision	App'd	for The City of Calgary				452.2006.001

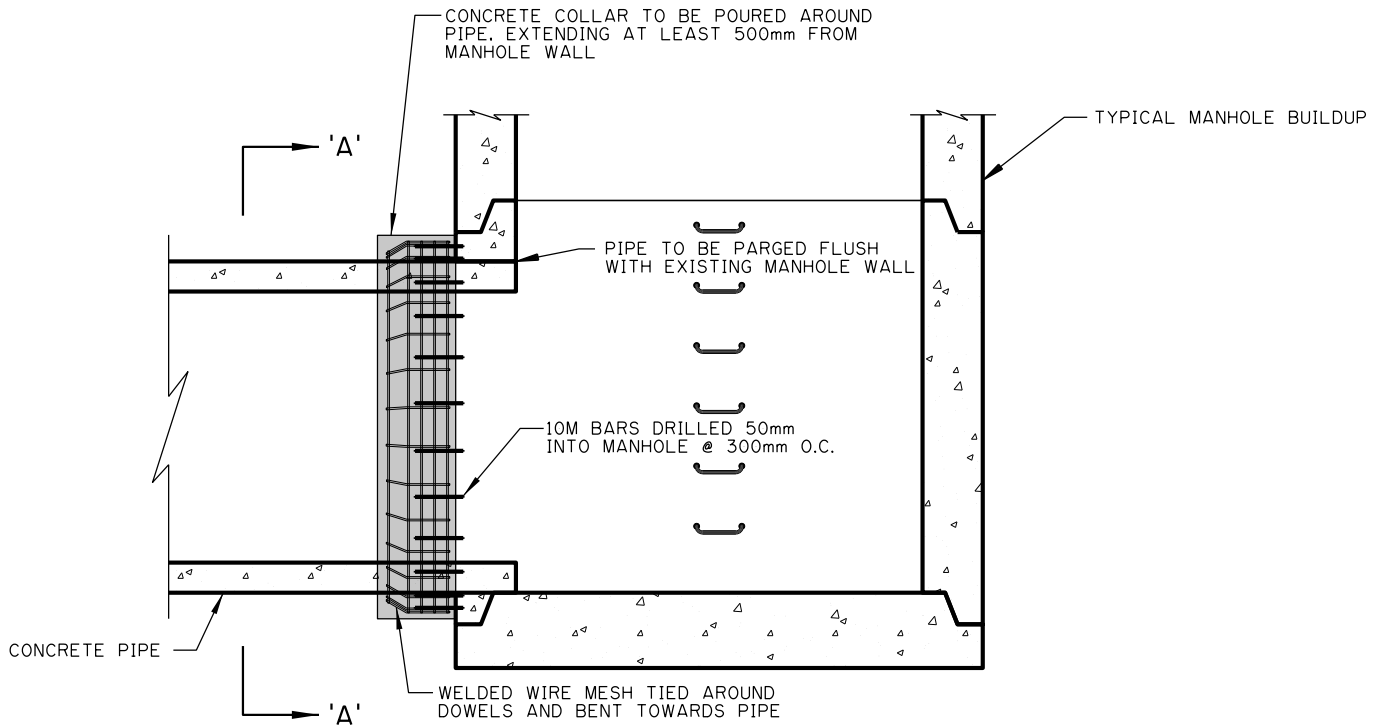

SECTION VIEW

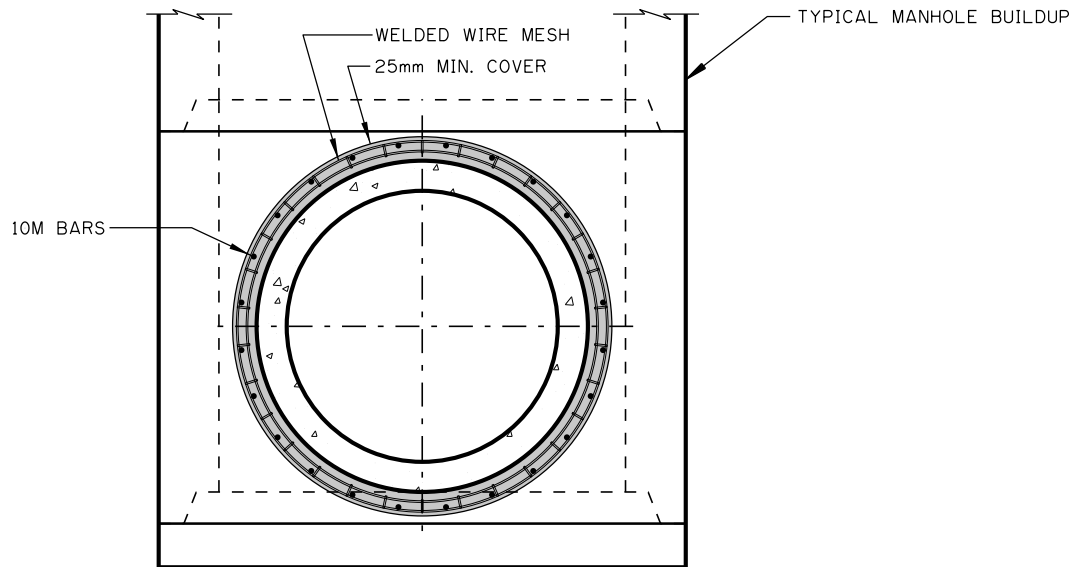

SECTION 'A-A'

MATERIAL SPECIFICATIONS:

1. CEMENT: SULPHATE RESISTANT TYPE: TYPE HS (TYPE 50) TO CSA A3001 OR TYPE V TO ASTM C150.
2. CONCRETE COMPRESSIVE STRENGTH: 35MPa @ 28 DAYS.
3. AIR CONTENT: 4% TO 7% EXCEPT WHERE NO SLUMP CONCRETE IS USED.

NOTES:

WHEN MANHOLE GAPS ARE GREATER THAN 50mm:

1. ALL DOWELED REBAR SIZE TO BE 10M.
2. WELDED WIRE MESH: W3/W2.1 MINIMUM.
3. REINFORCING STEEL: DEFORMED BARS TO CSA G30.18 fy=400 MPa.

DIMENSIONS ARE IN MILLIMETRES UNLESS OTHERWISE NOTED

No.	Date	Revision	App'd

Date
2020/02/11

Scale
NTS

Approved by
M. Chapman
for The City of Calgary



SEWER CONSTRUCTION

CONCRETE PIPE TO MANHOLE CONNECTION

Sheet
67

File Number
452.2007.001